

**ARMY TM 9-6150-226-13
AIR FORCE TO 35CA6-1-261**

**TECHNICAL MANUAL
OPERATOR AND FIELD MAINTENANCE MANUAL
FOR
DISTRIBUTION ILLUMINATION
SYSTEMS, ELECTRICAL (DISE) AND
POWER DISTRIBUTION ILLUMINATION SYSTEMS, ELECTRICAL (PDISE)
CONSISTING OF**

**ELECTRICAL FEEDER SYSTEM M200, M200 A/P
(6150-01-208-9755), (6150-01-308-5672)**

**ELECTRICAL FEEDER SYSTEM M100, M100 A/P
(6150-01-208-9754), (6150-01-308-5671)**

**ELECTRICAL DISTRIBUTION SYSTEM M40, M40 A/P
(6150-01-208-9753), (6150-01-307-9446)**

**ELECTRICAL DISTRIBUTION SYSTEM M60, M60 A/P
(6150-01-208-9752), (6150-01-307-9445)**

**ELECTRICAL UTILITY ASSEMBLY M46
(6150-01-208-9751)**

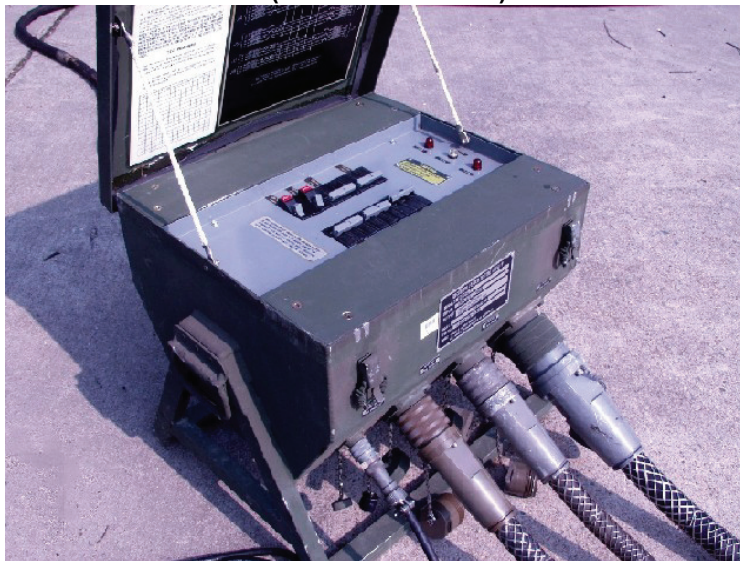

**DISTRIBUTION STATEMENT A. Approved for public release; distribution is unlimited.
This manual supercedes TM 9-6150-226-13, dated 30 May 1991.**



**HEADQUARTERS, DEPARTMENT OF THE ARMY
1 NOVEMBER 2008**

WARNING SUMMARY

This warning summary contains general safety warnings and hazardous materials warnings that must be understood and applied during operation and maintenance of this equipment. Failure to observe these precautions could result in serious injury or death to personnel. Also included are explanations of safety and hazardous material icons used within the technical manual.

FIRST AID

For first aid, refer to FM 4-25.11.

		
5	SAFETY STEPS TO FOLLOW IF SOMEONE IS THE VICTIM OF ELECTRICAL SHOCK	
1	DO NOT TRY TO PULL OR GRAB THE INDIVIDUAL	
2	IF POSSIBLE, TURN OFF THE ELECTRICAL POWER	
3	IF YOU CANNOT TURN OFF THE ELECTRICAL POWER, PULL, PUSH, OR LIFT THE PERSON TO SAFETY USING A DRY WOODEN POLE OR A DRY ROPE OR SOME OTHER INSULATING MATERIAL	
4	SEND FOR HELP AS SOON AS POSSIBLE	
5	AFTER THE INJURED PERSON IS FREE OF CONTACT WITH THE SOURCE OF ELECTRICAL SHOCK, MOVE THE PERSON A SHORT DISTANCE AWAY AND IMMEDIATELY START ARTIFICIAL RESUSCITATION	
<small>200KW-24M-120</small>		

WARNING SUMMARY (Continued)

SAFETY AND HAZARDOUS MATERIAL

This manual describes physical and chemical processes that may require the use of chemicals, solvents, paints, or other commercially available material. Users of the manual should obtain the material safety data sheets (Occupational Safety and Health Act (OSHA) Form 20 or equivalent) from the manufacturers or suppliers of materials to be used. Users must be completely familiar with manufacturer/supplier information and adhere to their procedures, recommendations, warnings, and cautions for safe use, handling, storage, and disposal of these materials.

EXPLANATION OF SAFETY WARNING ICONS



ELECTRICAL - electrical wire to hand with electricity symbol running through hand shows that shock hazard exists.



HOT AREA - hand over object radiating heat shows that part or area is hot and can burn.



EAR PROTECTION - headphones over ears shows that noise level will harm ears.



HEAVY OBJECT - human figure stooping over heavy object shows physical injury potential from improper lifting technique or failure to share lifting task with other persons.



HEAVY PARTS - hand with heavy object on top shows that heavy parts can crush and harm if dropped.



HEAVY PARTS - foot with heavy object on top shows that heavy parts can crush and harm if dropped

WARNING SUMMARY (Continued)



SHARP OBJECT - pointed object in hand shows that a sharp object presents a danger to limb.



HEAVY OBJECT - falling object shows that a heavy item can fall and crush.



EXPLOSION - flame and burst shows that material can explode if subjected to high temperatures, sources of ignition, or high pressure.

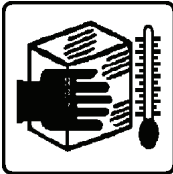

CRYOGENIC - hand in block of ice shows that the material is extremely cold and can injure human skin or tissue.

WARNING SUMMARY (Continued)

GENERAL SAFETY WARNINGS DESCRIPTION



WARNING

Metal jewelry will conduct electricity. Remove all jewelry when working on equipment. Failure to comply can cause injury or death to personnel by electrocution.

WARNING

High voltage is present when in operation. Make sure system is completely shut down and free of any power source before attempting any repair or maintenance on the unit. Failure to comply can cause injury or death to personnel.

WARNING

High voltage is present in the DISE and PDISE systems. Do not submerge cable connections in water. Death or serious injury may result.

WARNING

GROUND FAULT CIRCUIT BREAKERS are used in this equipment. DEATH ON CONTACT may result if personnel fail to observe safety precautions. Some of the 20-amp circuits on the DISE feeder and distribution centers use ground fault circuit breakers. The neutral and ground of some generator sets must be electrically connected with 6-gage wire for the ground fault circuit breakers to function properly. Failure to electrically connect the ground and neutral lugs may result in death or severe injury.

WARNING

HIGH VOLTAGE is used in the operation of this equipment. DEATH ON CONTACT may result if personnel fail to observe safety precautions. Never work on electrical equipment unless there is another person nearby who is familiar with the operation and hazards of the equipment and who is competent in administering first aid. When the technician is aided by operators, he must warn them about dangerous areas. The power supply to the equipment must be shut off before beginning to work on the equipment. The power source must be grounded at all times when equipment is in use or being worked on. Be careful not to contact high-voltage connections of 120/208 volts when installing or operating this equipment.

WARNING SUMMARY (Continued)

WARNING

High voltage is present in this system. DISE/PDISE supports equipment using 120/208 VAC. Do not rely on the color of the wire insulation for phase color-coding. The insulation on the wires inside the cable jacket may vary, depending on supplier. Wires will be color coded to designate the phases. If the wire color coding cannot be determined, notify next higher level of maintenance to perform continuity test. Perform a continuity test to verify correct phase designations in accordance with identified color. Failure to recognize this may result in death or serious personal injury.

WARNING

High voltage is present in all the DISE and PDISE systems. Disconnect power from generator before servicing. Death or serious injury may result.

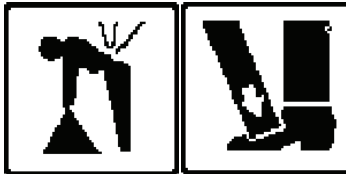

WARNING

Components can be extremely heavy and require an assistant and/or a lifting device (forklift, overhead lifting device) with sufficient capacity. Failure to comply can cause serious injury or death to personnel.



WARNING

Do not allow anyone under equipment suspended from a lifting device. Do not allow the unit to swing while suspended from a lifting device. Lack of attention or being in an improper position during lifting operations can result in serious injury or death to personnel and damage to the equipment.

WARNING SUMMARY (Continued)

HAZARDOUS WARNINGS DESCRIPTION-



WARNING

FLAMMABLE solvents and cleaning materials are used in the cleaning and maintenance of this equipment. Do not use flammables in areas where open flame or other ignition sources are present. Be sure that adequate ventilation is provided. Avoid inhalation of flammable liquids. Properly dispose of rags and other materials contaminated with flammable liquids. Have flame extinguishing equipment readily available when using flammable materials.

WARNING

Rivets can shatter during removal or installation and cause serious personal injury or death.

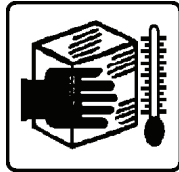

WARNING

In extreme cold weather, skin can stick to metal. Avoid contacting metal items with bare skin in extreme cold weather. Failure to comply can cause injury or death to personnel.

**ARMY TM 9-6150-226-13
AIR FORCE TO 35CA6-1-261**

LIST OF EFFECTIVE PAGES/WORK PACKAGES

NOTE: This manual supercedes TM 9-6150-226-13, dated 30 May 1991.
Zero in the "Change No." column indicates an original page or work package.

Date of issue for original manual is:

Original 1 November 2008

**TOTAL NUMBER OF PAGES FOR FRONT AND REAR MATTER IS 35 AND TOTAL
NUMBER OF WORK PACKAGES IS 40, CONSISTING OF THE FOLLOWING:**

Page/WP No.	*Change No.		Page/WP No.	*Change No.
Cover-1	0	WP 0009 (2 pg)	0	WP 0029 (12 pgs)
Cover-2 Blank	0	WP 0010 (4 pgs)	0	WP 0030 (2 pgs)
Warning summary (6 pgs)	0	Chp 6 Title page	0	WP 0031 (2 pgs)
A	0	Chp 6 Title page Blank	0	WP 0032 (2 pgs)
B-Blank	0	WP 0011 (2 pg)	0	WP 0033 (2 pgs)
i-xii (12 Pages)	0	WP 0012 (2 pgs)	0	WP 0034 (4 pgs)
Chp 1 Title page	0	WP 0013 (2 pg)	0	WP 0035 (6 pgs)
Chp 1 Title page Blank	0	WP 0014 (2 pgs)	0	WP 0036 (8 pgs)
WP 0001 (20 pgs)	0	WP 0015 (2 pgs)	0	WP 0037 (2 pgs)
WP 0002 (22 pgs)	0	WP 0016 (2 pgs)	0	WP 0038 (2 pgs)
Chp 2 Title page	0	WP 0017 (4 pgs)	0	WP 0039 (92 pgs)
Chp 2 Title page Blank	0	WP 0018 (4 pgs)	0	WP 0040 (2 pgs)
WP 0003 (14 pgs)	0	WP 0019 (6 pgs)	0	Chp 8 Title page
WP 0004 (4 pg)	0	WP 0020 (10 pgs)	0	Chp 8 Title page Blank
Chp 3 Title page	0	WP 0021 (4 pgs)	0	
Chp 3 Title page Blank	0	WP 0022 (2 pgs)	0	
WP 0005 (2 pgs)	0	WP 0023 (4 pgs)	0	
WP 0006 (2 pgs)	0	WP 0024 (4 pgs)	0	
Chp 4 Title page	0	WP 0025 (4 pgs)	0	
Chp 4 Title page Blank	0	WP 0026 (2 pgs)	0	
WP 0007 (2 pg)	0	WP 0027 (4 pgs)	0	
WP 0008 (6 pgs)	0	WP 0028 (2 pgs)	0	
Chp 5 Title page	0	Chp 7 Title page	0	
Chp 5 Title page Blank	0	Chp 7 Title page Blank	0	

A/B Blank

HEADQUARTERS
DEPARTMENT OF THE ARMY
WASHINGTON D.C., 1 Nov 2008

**TECHNICAL MANUAL
OPERATOR AND FIELD MAINTENANCE MANUAL
FOR
DISTRIBUTION ILLUMINATION
SYSTEMS, ELECTRICAL (DISE) AND
POWER DISTRIBUTION ILLUMINATION SYSTEMS, ELECTRICAL (PDISE)
CONSISTING OF**

**ELECTRICAL FEEDER SYSTEM M200, M200 A/P
(6150-01-208-9755), (6150-01-308-5672)**

**ELECTRICAL FEEDER SYSTEM M100, M100 A/P
(6150-01-208-9754), (6150-01-308-5671)**

**ELECTRICAL DISTRIBUTION SYSTEM M40, M40 A/P
(6150-01-208-9753), (6150-01-307-9446)**

**ELECTRICAL DISTRIBUTION SYSTEM M60, M60 A/P
(6150-01-208-9752), (6150-01-307-9445)**

**ELECTRICAL UTILITY ASSEMBLY M46
(6150-01-208-9751)**

REPORTING ERRORS AND RECOMMENDING IMPROVEMENTS

You can help improve this manual. If you find any mistakes or if you know of a way to improve the procedures, please let us know. Mail your letter or DA Form 2028 (Recommended Changes to Publications and Blank Forms), located in the back of this manual directly to: Commander, U.S. Army Communications Electronics Life Cycle Management Command (C-E LCMC) and Fort Monmouth, ATTN: AMSEL-LC-LEO-E-ED, Fort Monmouth, NJ 07703-5006. You may also send in your recommended changes via electronic mail or by fax. Our fax number is 732-532-1556, DSN 992-1556. Our e-mail address is MONM-AMSELLEOPUBSCHG@conus.army.mil. Our online web address for entering and submitting DA Form 2028s is <http://edm.monmouth.army.mil/pubs/2028.html>

(F) Air Force - By Air Force AFTO Form 22 (Technical Manual (TM) Change Recommendation and Reply) in accordance with paragraph 6-5, Section VI, TO 00-5-1 directly to prime ALC/MST.

DISTRIBUTION STATEMENT A. Approved for public release; distribution is unlimited.
This manual supercedes TM 9-6150-226-13, dated 30 May 1991.

TABLE OF CONTENTS

WP Sequence No.

Page No.

Warning Summary

List of Effective Pages

How to Use This Manual

Chapter 1 - General Information, Equipment Description, and Theory of Operation

General Information.....[WP 0001](#)

Figure 1. Typical Field Placement.....[0001-4](#)

Figure 2. Branch Cable and Light Assembly Placement.....[0001-5](#)

Figure 3. M200/M200 A/P Feeder System.....[0001-6](#)

Figure 4. M100/M100 A/P Feeder System.....[0001-7](#)

Figure 5. M40/M40 A/P Distribution System.....[0001-8](#)

Figure 6. M60/M60 A/P Distribution System.....[0001-9](#)

Figure 7. M46 Electrical Utility Kit.....[0001-10](#)

Table 1. DISE and PDISE Feeder/Distribution Centers.....[0001-13](#)

Table 2. DISE and PDISE Cables.....[0001-15](#)

Table 3. Approximate Voltage Losses at Rated Current.....[0001-16](#)

Figure 8. Example of Network Arrangement.....[0001-19](#)

Figure 9. Pairing of Generator Sets with Equipment.....[0001-20](#)

Description and Use of Operator Controls and Indicators.....[WP 0002](#)

Figure 1. M200 (DISE) System Control Panel.....[0002-2](#)

Figure 2. M200 A/P (PDISE) System Control Panel.....[0002-4](#)

Figure 3. M100 (DISE) System Control Panel.....[0002-6](#)

Figure 4. M100 A/P (PDISE) System Control Panel.....[0002-7](#)

Figure 5. M40 (DISE) System Control Panel.....[0002-9](#)

Figure 6. M40 A/P (PDISE) System Control Panel.....[0002-10](#)

Figure 7. M60 (DISE) System Control Panel.....[0002-12](#)

Figure 8. M60 A/P (PDISE) System Control Panel.....[0002-13](#)

Figure 9. Ground Fault Test Record.....[0002-14](#)

Figure 10. M200/M200 A/P Feeder Box Data Plates.....[0002-15](#)

Figure 11. M100/M100 A/P Feeder Box Data Plates.....[0002-17](#)

Figure 12. M40/M40 A/P Distribution Box Data Plates.....[0002-19](#)

Figure 13. M60/M60 A/P Distribution Box Data Plates.....[0002-21](#)

Chapter 2 – Operator Instructions

Operation Under Usual Conditions.....[WP 0003](#)

Table 1. Rule of Thumb Formula.....[0003-2](#)

Figure 1. Power Distribution Plan Example.....[0003-3](#)

TABLE OF CONTENTS (CONTINUED)

	<u>WP Sequence No.</u>
	<u>Page No.</u>
Figure 2. Power Distribution Layout Example.....	0003-5
Figure 3. Load Assignments Example.....	0003-6
Table 2. Connector to Phase Links.....	0003-7
Table 3. Feeder/Distribution Center Output Connector Loads.....	0003-8
Figure 4. Universal Adapter.....	0003-11
Operation Under Unusual Conditions.....	WP 0004
Chapter 3 –Operator Troubleshooting Procedures	
Operator Troubleshooting Index.....	WP 0005
Operator Troubleshooting.....	WP 0006
Chapter 4 – Operator Maintenance Procedures	
Preventive Maintenance Checks and Services (PMCS) Introduction	WP 0007
Preventive Maintenance Checks and Services (PMCS).....	WP 0008
Table 1. Operator Preventive Maintenance Checks and Services (PMCS).....	0008-1
Chapter 5 –Field Level Troubleshooting Procedures	
Field Troubleshooting Introduction	WP 0009
Table 1. Troubleshooting Index.....	0009-2
Field Troubleshooting Procedures.....	WP 0010
Chapter 6 –Field Level Maintenance Instructions	
Service Upon Receipt.....	WP 0011
PMCS Introduction	WP 0012
PMCS, Including Lubrication Instructions.....	WP 0013
Table 1. Preventive Maintenance Checks and Services (PMCS).....	0013-1
Preparation For Storage	WP 0014
Lanyard Assembly– Replace.....	WP 0015
Figure 1. Lanyard Assembly.....	0015-1
Circuit Breaker Panel Board– Replace.....	WP 0016
Figure 1. (DISE) Circuit Breaker Panel Board.....	0016-1
Figure 2. (PDISE) Circuit Breaker Panel Board.....	0016-2
Phase Indicator Light Assembly and Bulb– Replace.....	WP 0017
Figure 1. Phase Indicator Light Assembly.....	0017-2
Circuit Breaker – Replace, Test.....	WP 0018
Figure 1. (DISE) Circuit Breaker.....	0018-1

TABLE OF CONTENTS (CONTINUED)

	<u>Page No.</u>	<u>WP Sequence No.</u>
Figure 2. (PDISE) Circuit Breaker.....	0018-3	
Circuit Breaker and Bus Bar Assembly - Replace, Test.....		WP 0019
Figure 1. (DISE) Circuit Breaker Assembly.....	0019-1	
Figure 2. (DISE) Bus Bar Terminal.....	0019-2	
Figure 3. (PDISE) Circuit Breaker Assembly.....	0019-4	
Figure 4. (PDISE) Bus Bar and Ground Strap.....	0019-5	
Feeder/Distribution Connector Assembly – Replace, Test		WP 0020
Figure 1. Feeder/Distribution Connector Assembly.....	0020-2	
Table 1. M200/M200 A/P Feeder Center Continuity Checks.....	0020-3	
Table 2. M100/M100 A/P Feeder Center Continuity Checks.....	0020-5	
Table 3. M40/M40 A/P Distribution Center Continuity Checks.....	0020-7	
Table 4. M60/M60 A/P Distribution Center Continuity Checks.....	0020-9	
Cable Assemblies - Test		WP 0021
Table 1. Service/Feeder Cables, 200/100-Amp., 8-Pin Continuity Checks.....	0021-2	
Table 2. Service/Feeder Cables, 40/60-Amp., 5-Pin Continuity Checks.....	0021-2	
Table 3. Pigtail Cables, 200/100-Amp., 8-Pin Continuity Checks.....	0021-3	
Table 4. Pigtail Cables, 40/60-Amp., 5-Pin Continuity Checks.....	0021-3	
Table 5. Service/Feeder Cables, 60-Amp., 4-Pin Continuity Checks.....	0021-3	
Table 6. Pigtail Cables, 60-Amp., 4-Pin Continuity Checks.....	0021-2	
Table 7. Extension Cables, 20-Amp., 3-Pin Continuity Checks.....	0021-2	
Table 8. Branch Circuit Cables, 20-Amp., 3-Pin Continuity Checks.....	0021-2	
Dust and Moisture Sleeve-Replace.....		WP 0022
Figure 1. Dust and Moisture Sleeve.....	0022-2	
Gasket-Replace.....		WP 0023
Figure 1. Gasket.....	0023-2	
Duplex Receptacle Group-Replace, Test.....		WP 0024
Figure 1. Receptacle Box.....	0024-1	

TABLE OF CONTENTS (CONTINUED)

	<u>Page No.</u>	<u>WP Sequence No.</u>
Table 1. Duplex Receptacle Box Continuity Checks.....	0024-2	
Figure 2. Duplex Receptacle Box Wiring Diagram.....	0024-3	
Utility Light Assembly, Incandescent – Replace, Test.....		WP 0025
Figure 1. Incandescent Light Assembly.....	0025-1	
Table 1. Incandescent Utility Light Continuity Check.....	0025-3	
Figure 2. Incandescent Utility Light Assembly Wiring Diagram.....	0025-4	
Utility Light Assembly, Fluorescent 36" - Replace.....		WP 0026
Figure 1. Fluorescent Utility Light Assembly.....	0026-1	
Universal Adapter – Mounting Board and Input Connector – Replace, Test.....		WP 0027
Figure 1. Input Connector and Mounting Board.....	0027-2	
Table 1. Universal Adapter Continuity Checks.....	0027-3	
Figure 2. Universal Adapter Wiring Diagram.....	0027-4	
Universal Adapter – Load Terminal – Replace.....		WP 0028
Figure 1. Load Terminal.....	0028-2	
Cable-Type Connector - Repair.....		WP 0029
Figure 1. Cable Disassembly.....	0029-1	
Figure 2. Cable-Type Connector Assembly Layout.....	0029-3	
Figure 3. Pneumatic Crimper.....	0029-5	
Figure 4. Crimping Die.....	0029-6	
Figure 5. Connector Face/Key Positioning, 200/100-Amp, 8-Wire.....	0029-7	
Figure 6. Connector Face/Key Positioning, 40/60-Amp, 5-Wire.....	0029-8	
Figure 7. Connector Face/Key Positioning, 60-Amp, 4-Wire.....	0029-8	
Figure 8. Connector Face/Key Positioning, 20-Amp, 3-Wire.....	0029-9	
Figure 9. Installing Pin with Insertion Tool.....	0029-10	
Feeder/Distribution (Wall-Type) Connector – Repair.....		WP 0030
Figure 1. Connector Layout.....	0030-1	
General Wiring Maintenance/Wiring Diagrams.....		WP 0031
Table 1. Wall/Cable Connector Tool Selection.....	0031-3	
Table 2. Crimp Tools.....	0031-4	

TABLE OF CONTENTS (CONTINUED)

	<u>WP Sequence No.</u>
	<u>Page No.</u>
Table 3. DISE Feeder/Distribution Center Connector Repair/Fabrication Reference.....	0031-6
Table 4. PDISE Feeder/Distribution Center Connector Repair/Fabrication Reference.....	0031-7
Figure 1. M200 (DISE) Feeder Center Wiring Diagram.....	0031-9
Figure 2. M100 (DISE) Feeder Center Wiring Diagram.....	0031-11
Figure 3. M40 (DISE) Distribution Center Wiring Diagram.....	0031-12
Figure 4. M60 (DISE) Distribution Center Wiring Diagram.....	0031-13
Latch/Data Plate (Enclosure Assembly) – Replace, Repair.....	WP 0032
Chapter 7– Supporting Information	
References	WP 0033
Introduction for Standard Maintenance Allocation Chart (MAC)	WP 0034
Maintenance Allocation Chart (MAC)	WP 0035
Table 1. MAC for 60K IECU.....	0035-1
Table 2. Tools and Test Equipment Requirements	0035-5
Table 3. Remarks.....	0035-6
Component of End Items (COEI) and Basic Issue Items (BII List).....	WP 0036
Figure 1. M200/M200 A/P (COEI).....	0036-2
Table 1. M200/M200 A/P (COEI) List.....	0036-2
Figure 2. M100/M100 A/P (COEI).....	0036-3
Table 2. M100/M100A/P (COEI) List.....	0036-3
Figure 3. M40/M40 A/P (COEI).....	0036-4
Table 3. M40/M40 A/P (COEI) List.....	0036-4
Figure 4. M60/M60 A/P (COEI).....	0036-6
Table 4. M60/M60 A/P (COEI) List.....	0036-6
Figure 5. M46 and Auxiliary (COEI).....	0036-8
Table 5. M46 and Auxiliary (COEI) List.....	0036-8
Figure 6. Universal Adapter	0036-10
Table 6. Universal Adapter.....	0036-10
Additional Authorization List (AAL) Items.....	WP 0037
Expendable/Durable Supplies and Materials List.....	WP 0038
Table 1. Expendable/Durable Supplies and Materials List.....	0038-2

TABLE OF CONTENTS (CONTINUED)

	<u>WP Sequence No.</u>
	<u>Page No.</u>
Illustrated List of Manufactured Items.....	WP 0039
Table 1. Manufactured Items Part Number Index.....	0039-1
Table 2. Service/Feeder Cable, 40/60-Amp, 25 ft.....	0039-5
Figure F-1. Service/Feeder Cable, 40/60-Amp, 25 ft.....	0039-6
Table 3. Service/Feeder Cable, 40/60-Amp, 100 ft.....	0039-8
Figure F-2. Service/Feeder Cable, 40/60-Amp, 100 ft.....	0039-9
Table 4. Service/Feeder Cable, 60-Amp, 50 ft.....	0039-11
Figure F-3. Service/Feeder Cable, 60-Amp, 50 ft.....	0039-12
Table 5. Extension Cable, 20-Amp, 3.5 ft.....	0039-14
Figure F-4. Extension Cable, 20-Amp, 3.5 ft.....	0039-15
Table 6. Input Connector Assembly, 200-Amp (J1) (DISE)..	0039-17
Figure F-5. Input Connector Assembly, 200-Amp (J1) (DISE)...	0039-18
Table 7. Input Connector Assembly, 100-Amp (J1) (DISE).....	0039-18
Figure F-6. Input Connector Assembly, 100-Amp (J1) (DISE).....	0039-18
Table 8. Feeder Center Output Connector Assembly, 100-Amp M200 (J4, J5, J11), M100 (J2) (DISE).....	0039-21
Figure F-7. Feeder Center Output Connector Assembly, 100-Amp M200 (J4, J5, J11), M100 (J2) (DISE).....	0039-22
Table 9. Distribution Center Input Connector Assembly, 40-Amp M40 (J1) (DISE).....	0039-23
Figure F-8. Distribution Center Input Connector Assembly, 40-Amp M40 (J1) (DISE).....	0039-24
Table 10. Feeder Center Output Connector Assembly, 40/60-Amp M200 (J7, J8, J9, J10) (DISE)..... Feeder Center Output Connector Assembly, 40/60-Amp M100 (J3, J4, J5, J6) (DISE)..... Distribution Center Output Connector Assembly 40/60-Amp, M40 (J2) (DISE).....	0039-25
Figure F-9. Feeder Center Output Connector Assembly, 40/60-Amp M200 (J7, J8, J9, J10) (DISE)..... Feeder Center Output Connector Assembly, 40/60-Amp M100 (J3, J4, J5, J6) (DISE)..... Distribution Center Output Connector Assembly 40/60-Amp, M40 (J2) (DISE).....	0039-26
Table 11. Distribution Center Input Connector Assembly, 60-Amp	

TABLE OF CONTENTS (CONTINUED)

	<u>WP Sequence No.</u>
	<u>Page No.</u>
M60 (J1) (DISE).....	0039-27
Figure F-10. Distribution Center Input Connector Assembly, 60-Amp M60 (J1) (DISE).....	0039-28
Table 12. Distribution Center Output Connector Assembly, 60-Amp M60 (J2) (DISE).....	0039-29
Figure F-11. Distribution Center Output Connector Assembly, 60-Amp M60 (J2) (DISE).....	0039-30
Table 13. Distribution Center Output Connector Assembly, 20-Amp M40 (J3 thru J14), M60 (J3 thru J8) (DISE).....	0039-31
Figure F-12. Distribution Center Output Connector Assembly, 20-Amp M40 (J3 thru J14), M60 (J3 thru J8) (DISE).....	0039-32
Table 14. Feeder Center Output Connector Assembly, 60-Amp M200 (J6), M100 (J8) (DISE).....	0039-33
Figure F-13. Feeder Center Output Connector Assembly, 60-Amp M200 (J6), M100 (J8) (DISE).....	0039-34
Table 15. Feeder Center Output Connector Assembly, 20-Amp M100 (J7) (DISE).....	0039-35
Figure F-14. Feeder Center Output Connector Assembly, 20-Amp M100 (J7) (DISE).....	0039-36
Table 16. Pigtail Cable, 200-Amp, 4 ft.....	0039-37
Figure F-15. Pigtail Cable, 200-Amp, 4 ft.....	0039-38
Table 17. Pigtail Cable, 100-Amp, 4 ft.....	0039-40
Figure F-16. Pigtail Cable, 100-Amp, 4 ft.....	0039-41
Table 18. Pigtail Cable, 40/60-Amp, 4ft.....	0039-43
Figure F-17. Pigtail Cable, 40/60-Amp, 4ft.....	0039-44
Table 19. Pigtail Cable, 60-Amp, 4ft.....	0039-46
Figure F-18. Pigtail Cable, 60-Amp, 4 ft.....	0039-47
Table 20. Service/Feeder Cable, 200-Amp, 25 ft.....	0039-49
Figure F-19. Service/Feeder Cable, 200-Amp, 25 ft.....	0039-50
Table 21. Service/Feeder Cable, 100-Amp, 50 ft.....	0039-52
Figure F-20. Service/Feeder Cable, 100-Amp, 50 ft.....	0039-53
Table 22. Service/Feeder Cable, 40/60-Amp, 50 ft.....	0039-55
Figure F-21. Service/Feeder Cable, 40/60-Amp, 50 ft.....	0039-56
Table 23. Service/Feeder Cable, 60-Amp, 100 ft.....	0039-58
Figure F-22. Service/Feeder Cable, 60-Amp, 100 ft.....	0039-59

TABLE OF CONTENTS (CONTINUED)

	<u>WP Sequence No.</u>
	<u>Page No.</u>
Table 24. Extension Cable, 20-Amp, 15 ft.....	0039-61
Figure F-23. Extension Cable, 20-Amp, 15 ft.....	0039-62
Table 25. Extension Cable, 20-Amp, 25 ft.....	0039-64
Figure F-24. Extension Cable, 20-Amp, 25 ft.....	0039-65
Table 26. Extension Cable, 20-Amp, 50 ft.....	0039-67
Figure F-25. Extension Cable, 20-Amp, 50 ft.....	0039-68
Table 27. Input Connector Assembly, 200-Amp (J1) (PDISE)..	0039-70
Figure F-26. Input Connector Assembly, 200-Amp (J1) (PDISE).....	0039-71
Table 28. Input Connector Assembly, 100-Amp (J1) (PDISE).....	0039-72
Figure F-27. Input Connector Assembly, 100-Amp (J1) (PDISE).....	0039-73
Table 29. Feeder Center Output Connector Assembly, 100-Amp M200 A/P (J4) (PDISE)	0039-74
Table 30. Feeder Center Output Connector Assembly, 100-Amp M200 A/P (J5) (PDISE).....	0039-74
Table 31. Feeder Center Output Connector Assembly, 100-Amp M200 A/P (J11) (PDISE).....	0039-75
Table 32. Feeder Center Output Connector Assembly, 100-Amp M100 A/P (J2) (PDISE).....	0039-75
Figure F-28. Feeder Center Output Connector Assembly, 100-Amp M200 A/P (J4, J5, J11), M100 A/P (J2) (PDISE).....	0039-76
Table 33. Distribution Center Input Connector Assembly, 40-Amp M40 A/P (J1) (PDISE).....	0039-77
Figure F-29. Distribution Center Input Connector Assembly, 40-Amp M40 A/P (J1) (PDISE).....	0039-78
Table 34. Feeder Center Output Connector Assembly, 40/60-Amp M200 A/P (J7 and J9) (PDISE).....	0039-79
Table 35. Feeder Center Output Connector Assembly, 40/60-Amp M200 A/P (J8 and J10) (PDISE).....	0039-79
Table 36. Feeder Center Output Connector Assembly, 40/60-Amp M100 A/P (J3 and J5) (PDISE).....	0039-80
Table 37. Feeder Center Output Connector Assembly, 40/60-Amp M100 A/P (J4 and J6) (PDISE).....	0039-80
Table 38. Distribution Center Output Connector Assembly 40/60-Amp, M40 A/P (J2) (PDISE).....	0039-80
Figure F-30. Feeder Center Output Connector Assembly, 40/60-Amp M200 A/P (J7, J8, J9, J10) (PDISE).....	
Feeder Center Output Connector Assembly, 40/60-Amp	

TABLE OF CONTENTS (CONTINUED)

	<u>Page No.</u>	<u>WP Sequence No.</u>
..... M100 A/P (J3, J4, J5, J6) (PDISE).....		
Distribution Center Output Connector Assembly 40/60-Amp, M40 A/P (J2) (PDISE).....	0039-81	
Table 39. Distribution Center Input Connector Assembly, 60-Amp M60 A/P (J1) (PDISE).....	0039-82	
Figure F-31. Distribution Center Input Connector Assembly, 60-Amp M60 A/P (J1) (PDISE).....	0039-83	
Table 40. Distribution Center Output Connector Assembly, 60-Amp M60 A/P (J2) (PDISE).....	0039-84	
Figure F-32. Distribution Center Output Connector Assembly, 60-Amp M60 A/P (J2) (PDISE).....	0039-85	
Table 41. Distribution Center Output Connector Assembly, 20-Amp M40 A/P (J3, J5, J7, J9, J11, J13) (PDISE).....	0039-86	
Table 42. Distribution Center Output Connector Assembly, 20-Amp M40 A/P (J4, J6, J8, J10, J12, J14) (PDISE).....	0039-86	
Table 43. Distribution Center Output Connector Assembly, 20-Amp M60 A/P (J3, J5, J7,) (PDISE).....	0039-87	
Table 44. Distribution Center Output Connector Assembly, 20-Amp M60 A/P (J4, J6, J8,) (PDISE).....	0039-87	
Figure F-33. Distribution Center Output Connector Assembly, 20-Amp M40 A/P (J3 thru J14), M60 (J3 thru J8) (PDISE).....	0039-88	
Table 45. Feeder Center Output Connector Assembly, 20-Amp M200 A/P (J6) (PDISE).....	0039-89	
Table 46. Feeder Center Output Connector Assembly, 20-Amp M100 A/P (J8) (PDISE).....	0039-89	
Figure F-34. Feeder Center Output Connector Assembly, 20-Amp M200 A/P (J6) and M100 A/P (J8) (PDISE).....	0039-90	
Table 47. Feeder Center Output Connector Assembly, 20-Amp M100 A/P (J7) (PDISE).....	0039-91	
Figure F-35. Feeder Center Output Connector Assembly, 20-Amp M100 A/P (J7) (PDISE).....	0039-92	
Torque Limits -.....		WP 0040
Table 1. Torque Limits for Circuit Breaker Lugs (DISE).....	0040-1	
Table 2. Torque Limits for Circuit Breaker Lugs (PDISE).....	0040-2	
Table 3. Torque Limits for Self-Locking Nuts.....	0040-2	
Chapter 8– Rear Matter.....		

HOW TO USE THIS MANUAL

This manual is divided into Work Packages (WP). Each WP is an independent, task-oriented unit. Only essential information is provided. WPs cover the subjects of theory of operation, operating instructions, troubleshooting, preventative maintenance checks, maintenance instructions, and fabrication of certain components. The Table of Contents provides a complete list of chapters and WPs pertinent to the maintaining of all DISE/PDISE systems. The WPs are arranged in numerical sequence based on the maintenance level or task associated for breakdown. There may be two separate procedures associated for the DISE model systems and the PDISE model systems. Commonalities and differences in the models are described in WP 0001. Each maintenance WP lists the tasks covered, initial set-up requirements, tools required, equipment conditions, reference materials and material/parts required. Maintenance procedures are sometimes integrated with illustrations. To locate information, refer to the Table of Contents in the front of the TM. References to tables or figures within a WP are made by numbers, e.g. Table 2, or Figure 3. A reference to another WP merely includes the WP number, e.g. WP 0003. To find a particular procedure or topic, it is necessary to refer to that WP. In most cases, redundant procedures may resort to the applicable WP that that particular component be referenced. To find a particular part for replacement, it will be necessary to use the Repair Parts and Special Tools List (RPSTL), TM 9-6150-226-13P (also known as the Illustrated Parts Breakdown). Detailed instructions for use of the RPSTL are found in TM 9-6150-226-13P.

GENERAL

In order to use this manual efficiently, there are several things you need to know. All references in this manual are to work packages or to another manual. Throughout this manual, text is keyed to illustrations by numbered callouts. When an item is called out in a procedure, a number in parentheses in the text corresponds with a number on the illustration.

INDEXES

This manual is organized to help you quickly find the information needed. There are useful indexes or lists:

Table of Contents. The Table of Contents lists, in the order of presentation, all chapters, and Work Packages contained in this manual.

Troubleshooting Symptom Index. The Troubleshooting Symptom Index lists parts of the system and possible malfunctions with references to the corrective action.

Component of End Item (COEI). A list of items that are part of the end item, but are shipped separately. It is not an authorization to requisition replacements.

Basic Issue Items (BII). A list of minimum essential items required when system

Chapter 1

General Information Equipment Description and Theory of Operation

**OPERATOR, FIELD AND SUSTAINMENT MAINTENANCE
DISE AND PDISE SYSTEMS
GENERAL INFORMATION**

SCOPE

This manual contains an equipment description, operating instructions and maintenance procedures for the electrical distribution and illumination systems (Distribution Illumination Systems, Electrical-DISE) and (Power Distribution Illumination Systems, Electrical-PDISE). It also includes references to other publications and maintenance information in support of this equipment. This manual covers the following models:

- | <u>DISE</u> | <u>PDISE</u> |
|--|--|
| (1) M200 Electrical Feeder System; | M200 A/P Electrical Feeder System |
| (2) M100 Electrical Feeder System; | M100 A/P Electrical Feeder System |
| (3) M40 Electrical Distribution System; | M40 A/P Electrical Distribution System |
| (4) M60 Electrical Distribution System ; | M60 A/P Electrical Distribution |
| (5) M46 Electrical Utility Assembly; | |
| (6) Auxiliary Equipment | |

The main purpose of this equipment is to distribute electrical power from the power source (supplied separately) to user equipment during field conditions and to provide illumination for field shelters.

MAINTENANCE FORMS AND RECORDS.

Department of the Army forms and procedures used for equipment maintenance will be those prescribed by DA Pam 750-8, The Army Maintenance Management System (TAMMS) update.

REPORTING EQUIPMENT IMPROVEMENT RECOMMENDATION (EIR).

If your equipment needs improvement, let us know. Send us an EIR. You, the user, are the only one who can tell us what you don't like about your equipment. Let us know why you don't like the design or performance. Put it on an SF 368 (Product Quality Deficiency Report). Mail it to us at: Commander, US Army Communications-Electronics and Life Cycle Material Command, Fort Monmouth, New Jersey 07703-5006, ATTN: AMSEL-LC-LEO-D-CS-CFO. We will send you a reply.

CORROSION PREVENTION AND CONTROL

Corrosion Prevention and Control (CPC) of Army material is a continuing concern. It is important that any Corrosion problems with this item be reported so that the problem can be corrected and improvements can be made to prevent the problem in future items. While corrosion is typically associated with rusting of Metals, it can also include deterioration of other materials, such as rubber and plastic. Unusual cracking, softening, swelling, or breaking of these materials may be a corrosion problem.

If a corrosion problem is identified, it can be reported using SF 368. Use of key words such as "corrosion", "rust", "deterioration", or "cracking" will ensure that the information is identified as a CPC problem. The form should be submitted to the address specified in DA PAM 750-8, Functional Users Manual for the Army Maintenance Management System (TAMMS).

DESTRUCTION OF ARMY MATERIEL TO PREVENT ENEMY USE.

For general destruction procedures for this equipment, refer to TM 750-244-3, Procedures for Destruction of Equipment to Prevent Enemy Use (Mobility Equipment Command).

PREPARATION FOR STORAGE AND SHIPMENT

Before placing the DISE/PDISE system in storage or preparing for shipment, all maintenance checks and services must be applied; defects and failures corrected; and Maintenance Work Orders (MWO's) applied. See WP 0011 for applicable Service Level PMCS and WP 0014 for proper storage information.

WARRANTY INFORMATION

Warranty procedures for DISE/PDISE components are listed in TB-6150-226-23.

OFFICIAL NOMENCLATURE AND CROSS-REFERENCE

There is no nomenclature used in this manual which deviates from official nomenclature. List of unusual terms used are located in the Glossary.

LIST OF ABBREVIATIONS

ac.....	Alternating current
amp.....	Amperage
amp/ph.....	Amperage per phase
app.....	Appendix
cm.....	Centimeter (s)
CTA.....	Common Table of Allowances
EIR.....	Equipment Improvement Report
Hz.....	Hertz
ISO.....	International Standardization Organization
kg.....	Kilogram (s)
kW.....	Kilowatt (s)
lb.....	Pound (s)
m.....	Meter (s)
Max.....	Maximum
mm.....	Millimeter (s)
MTOE.....	Modification Table of Organization and Equipment
N.m.....	Newton-meter (s)
No.....	Number
NSN.....	National Stock Number
pf.....	Power Factor
ph.....	Phase
PMCS.....	Preventative Maintenance Checks and Services
pneu.....	Pneumatic
sys.....	System
TMDE.....	Test, Measurement, and Diagnostic Equipment
V.....	Volts
VAC.....	Volts alternating currents
W.....	Watts

QUALITY ASSURANCE/QUALITY CONTROL

The following manuals are required for quality assurance/quality control of DISE and PDISE equipment: TM 9-237; TM 38-230-1; TM 38-230-2, TM 43-0139; and FM 10-16.

SAFETY, CARE AND HANDLING.

Be alert and adhere to **WARNINGS**, **CAUTIONS**, and **NOTES**. These provide for safe operation of the equipment, and protect you and your equipment from injury and damage.

CALIBRATION

DISE/PDISE equipment does not require calibration.

SUPPORTING INFORMATION FOR REPAIR PARTS AND SPECIAL TOOLS EQUIPMENT

Refer to the Maintenance Allocation Chart (MAC) in WP 0034 for a listing of maintenance items and tools or test equipment. Refer to TM 9-6150-226-13P (Repair Parts and Special Tools List Maintenance Manual) for any parts and materials information.

EQUIPMENT CHARACTERISTICS, CAPABILITIES, AND FEATURES.

- DISE/PDISE is a family of power distribution and illumination equipment which transmits electrical power between power generation and power using equipment. Some DISE/PDISE supplements current field illumination and adds distribution capabilities.
- DISE/PDISE consists of items illustrated and listed in Figures 2 through 7. It is used to form a consolidated power network by adding components to meet specific organizational missions and requirements.
- DISE/PDISE permits using fields more flexibility by consolidating power sources.
- DISE/PDISE provides flexibility to field operations and can be quickly assembled/disassembled for rapid relocation.
- DISE/PDISE equipment is designed for basic climatic (120 to -25° F [49 to -32° C) and field conditions.
- DISE/PDISE equipment is designed to be used with generator sets (120/208 VAC, 50/60 Hz, 5 to 200 kW).
- DISE/PDISE system and user's electrical equipment are protected by circuit breakers within the DISE/PDISE equipment.
- DISE/PDISE equipment uses military standard connectors.
- DISE/PDISE equipment is compatible with International Standardization Organization (ISO) containers and Tent Extendable, Modular, Personnel (TEMPER).
- Line distance from generator to load is limited to a total of 300 feet (91.4m) at maximum load, because line distance greater than 300 feet (91.4m) would cause an unacceptable voltage loss. Refer to Table 3 to determine voltage loss at rated current.
- The M46 electrical utility assembly can be used to illuminate field shelters. The M46 is not intended to replace existing lighting sets, but is intended to augment and expand current capabilities.

LOCATION AND DESCRIPTION OF MAJOR COMPONENTS.

Typical System Placement. The quantity, location, and placement of DISE and PDISE equipment is dependent upon field conditions and user needs. Figure 1 is a typical field placement of a 3-phase power distribution system. Figure 2 shows details of DISE and PDISE equipment inside the user's tent.

System Components. The components of the five basic systems for DISE and PDISE are illustrated in Figures 2 thru 7.

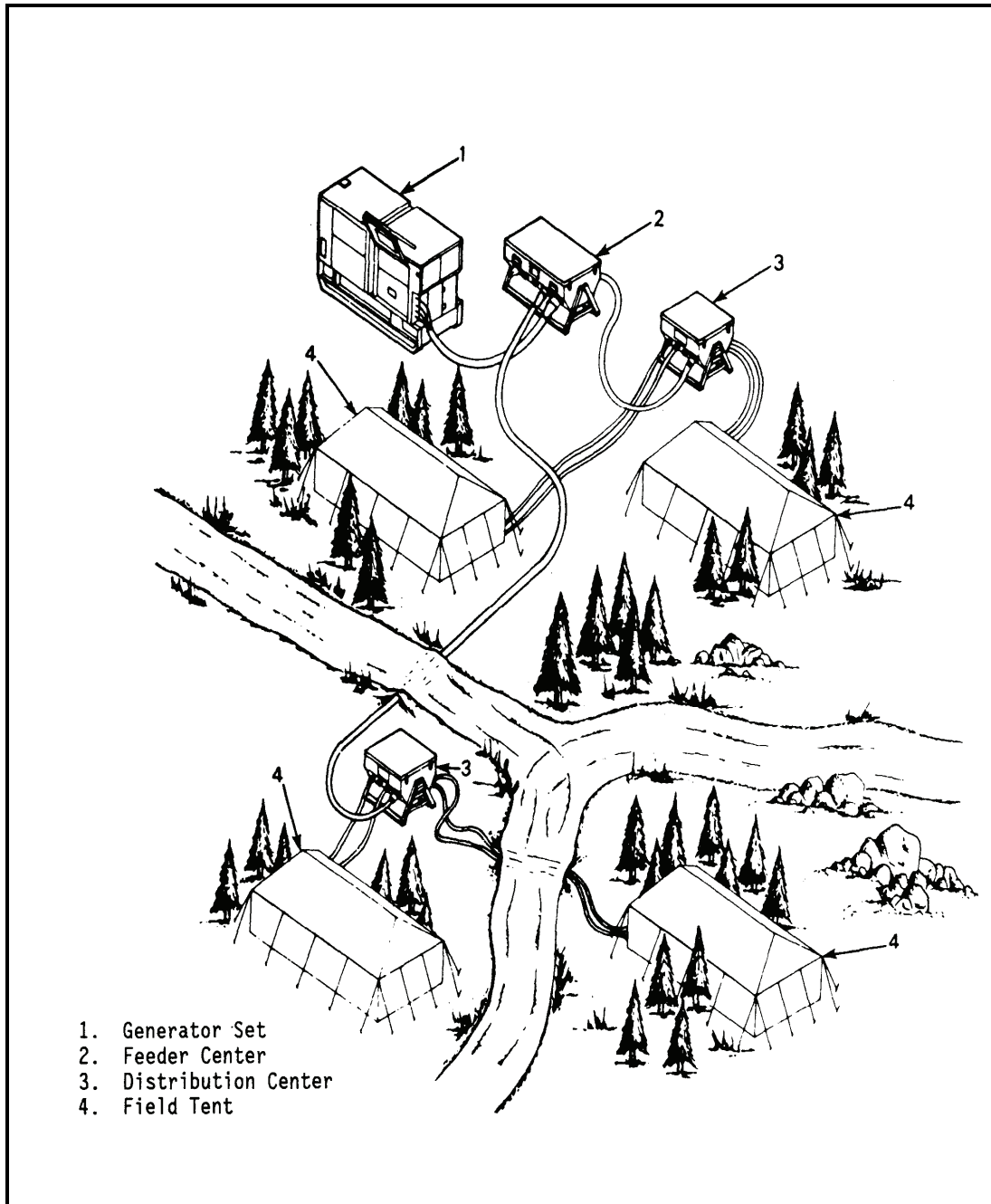

Figure 1. Typical Field Placement

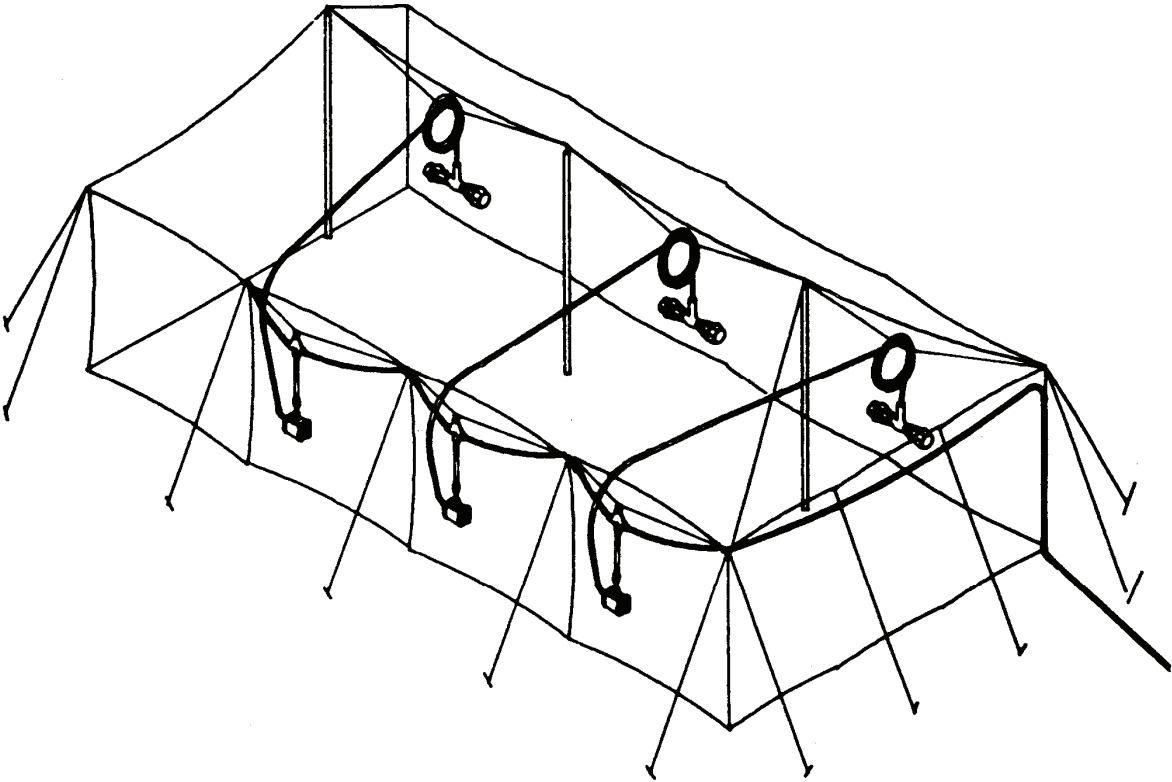

Figure 2. DISE and PDISE Branch Cable and Light Assemblies.

M200/M200 A/P- (3 Phase) Electrical Feeder System Component Listing (See Figure 3)

- (1) Electrical feeder center, 3-ph, 120/208 V, 200 amp/ph
- (2) Pigtail cable assembly, 4 ft (1.2 m), 200-amp, 8-pin
- (3) Service/feeder cable assembly, 25 ft (7.6m), 200-amp, 8-pin (4 ea.)
- (4) Cable carrying strap (16 ea)

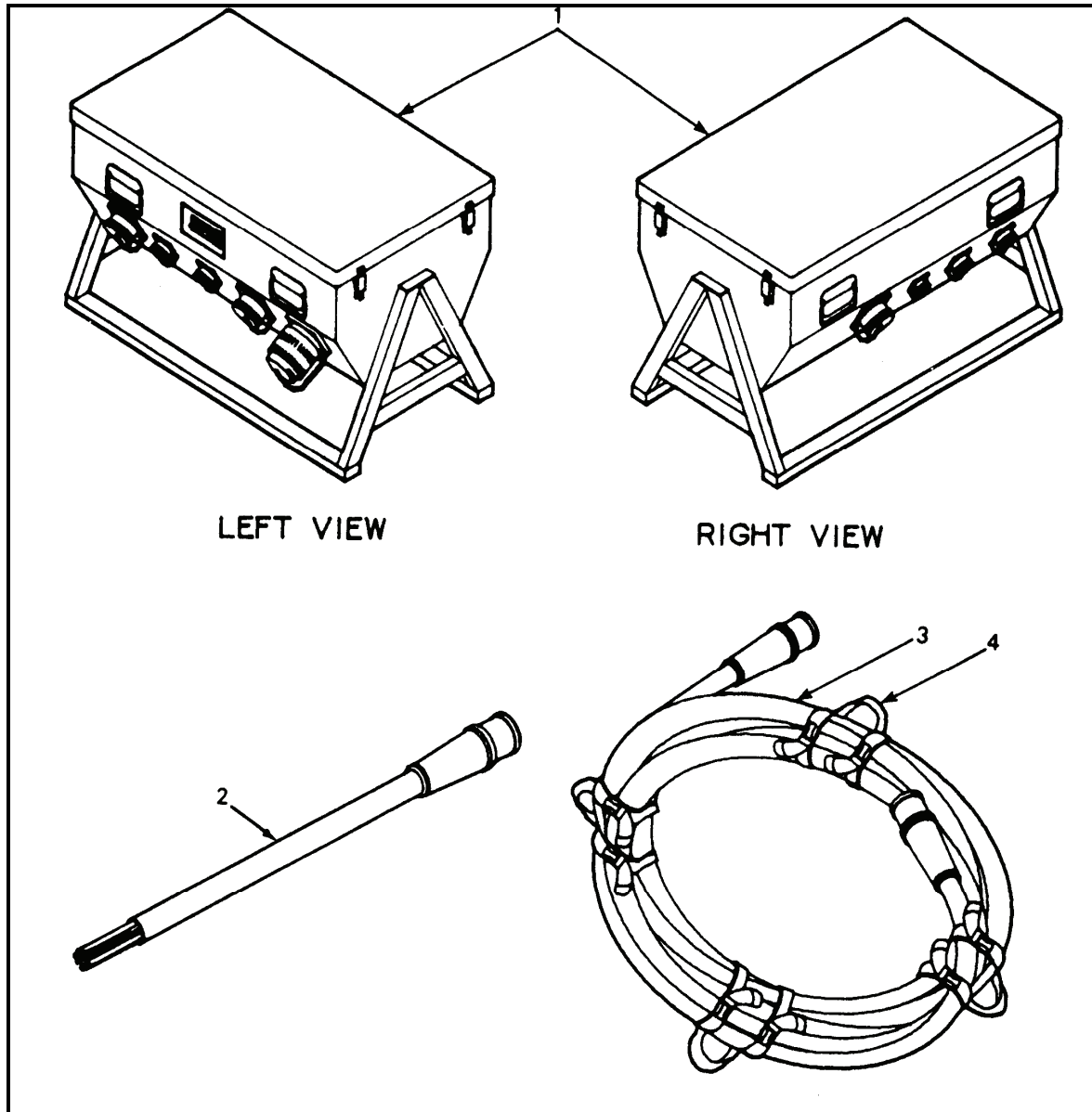

Figure 3. Electrical Feeder System, M200 and M200 A/P, (3-Phase).

M100/M100 A/P- (3 Phase) Electrical Feeder System Component Listing (See Figure 4)

- (1) Electrical feeder center, 3-ph, 120/208 V, 100 amp/ph
- (2) Pigtail cable assembly, 4 ft (1.2 m), 100-amp, 8-pin
- (3) Service/feeder cable assembly, 50 ft (15.2 m), 100-amp, 8-pin (2 ea)
- (4) Cable carrying strap (8 ea)

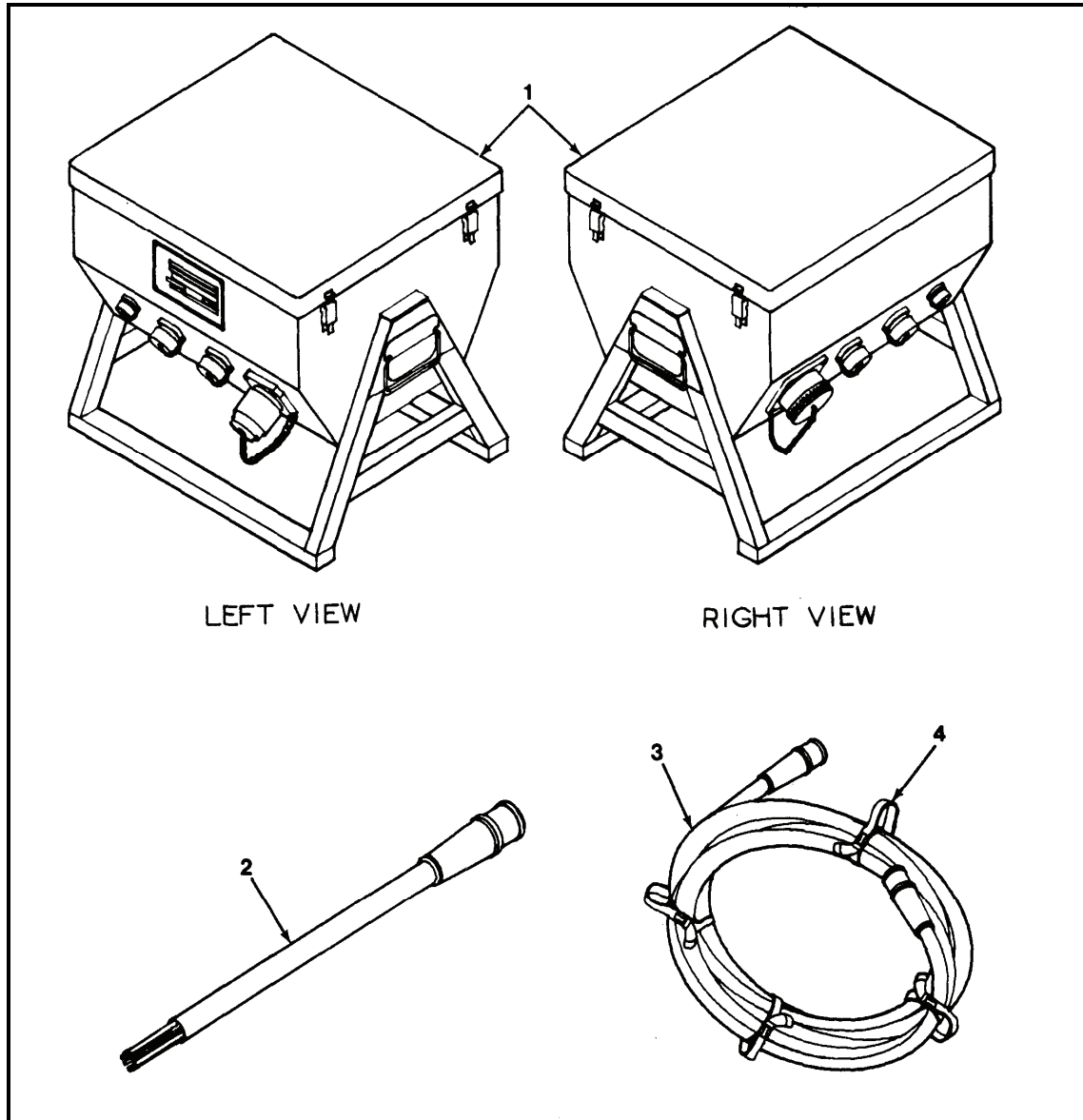

Figure 4. Electrical Feeder System, M100 and M100 A/P, 3-Phase.

M40/ M40 A/P- (3 Phase) Electrical Distribution System Component Listing (See Figure 5)

- (1) Distribution center, 3-ph, 120/208 VAC, 40 amp/ph
- (2) Pigtail cable, 4 ft (1.2 m), 40 amps, 5-pin
- (3) Service/feeder cable assembly, 50 ft (15.2 m), 40/60-amp, 5-pin (2 ea)
- (4) Cable carrying strap (8 ea)
- (5) Extension cable assembly, 50 ft (15.2 m), 20-amp, 3-pin (3 ea)
- (6) Extension cable assembly, 25 ft (7.6 m), 20-amp, 3-pin (3 ea)
- (7) Receptacle group 2-duplex box enclosure, 120 VAC, 20 amp
- (8) Packing List
- (9) Transit and storage container
- (10) Interface cable

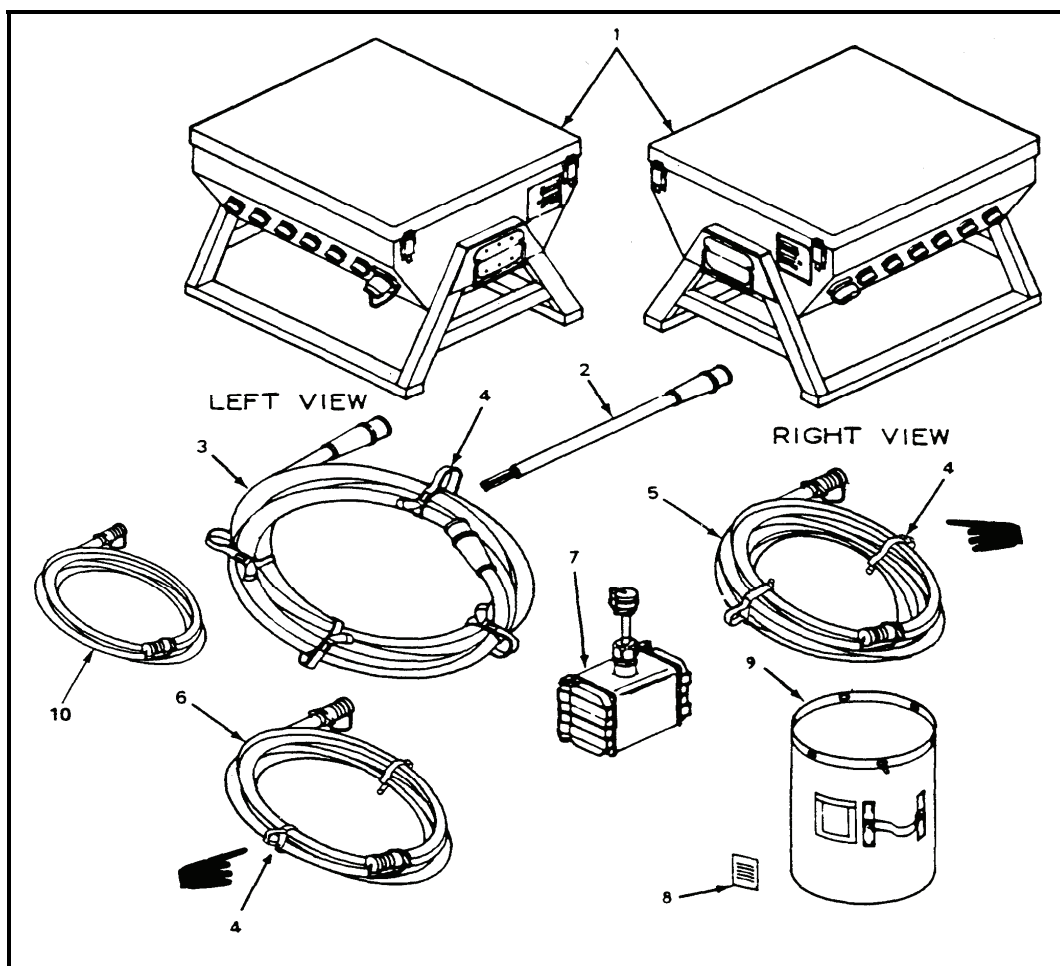

Figure 5. Electrical Distribution System, M40 and M40 A/P, 3-Phase.

M60/M60 A/P- (Single Phase) Electrical Distribution System Component Listing (See Figure 6)

- (1) Distribution center, single-phase, 120 V, 60 amp
- (2) Pigtail cable assembly, 4 fit (1.2 m), 60-amp, 4-pin
- (3) Service/feeder cable assembly, 100 ft (30.5 m), 60-amp, 4-pin
- (4) Cable carrying strap (4 ea)
- (5) Extension cable assembly, 50 ft (15.2 m), 20-amp, 3-pin (3 ea)
- (6) Extension cable assembly, 25 ft (7.6 m), 20-amp, 3-pin (3 ea)
- (7) Receptacle group 2-duplex box enclosure, 120 V, 20 amp
- (8) Packing List
- (9) Transit and storage-container
- (10) Interface cable

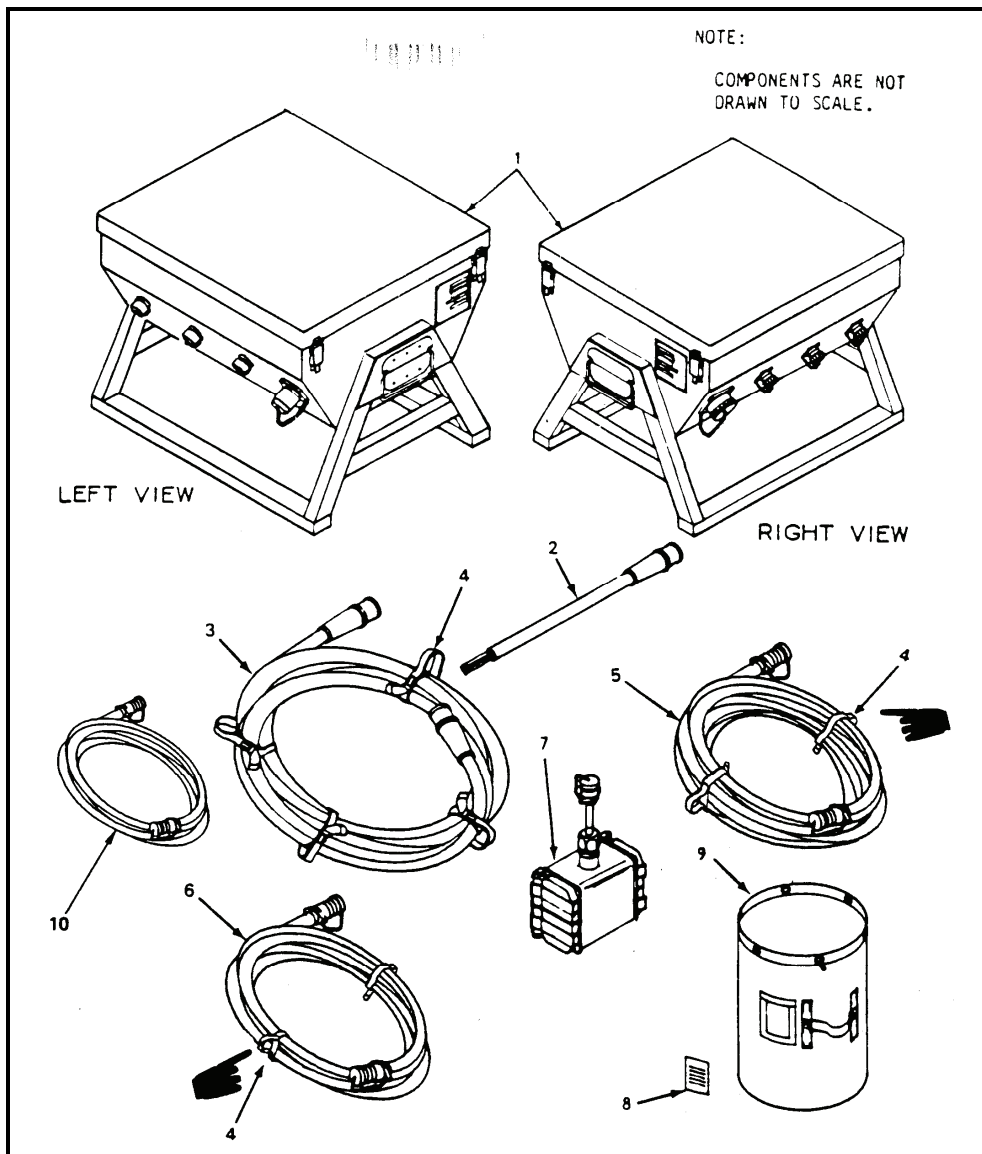

Figure 6. Electrical Distribution System, M60 and M60 A/P Single-Phase.

M46/ Electrical Utility Kit Component Listing (See Figure 7)

- (1) Extension cable assembly, 25 ft (7.6m), 20-amp, 3-pin (6 ea)
- (2) Branch circuit cable assembly, 12-outlet, 24 ft (7.3 m), 20-amp, 3-pin, 3-drop (2 ea)
- (3) Utility light, 120 V, dual socket, incandescent (2 ea) (optional with or w/o item 8)
- (4) Light bulbs kit: blue 40 W (2), white 75 W (2 ea)
- (5) Rope Assembly (2 ea)
- (6) Cable securing strap (8 ea)
- (7) Transit storage container
- (8) 50 W Twin Compact Fluorescent Bulb (2 ea) 36' in. (optional with or w/o item 3)

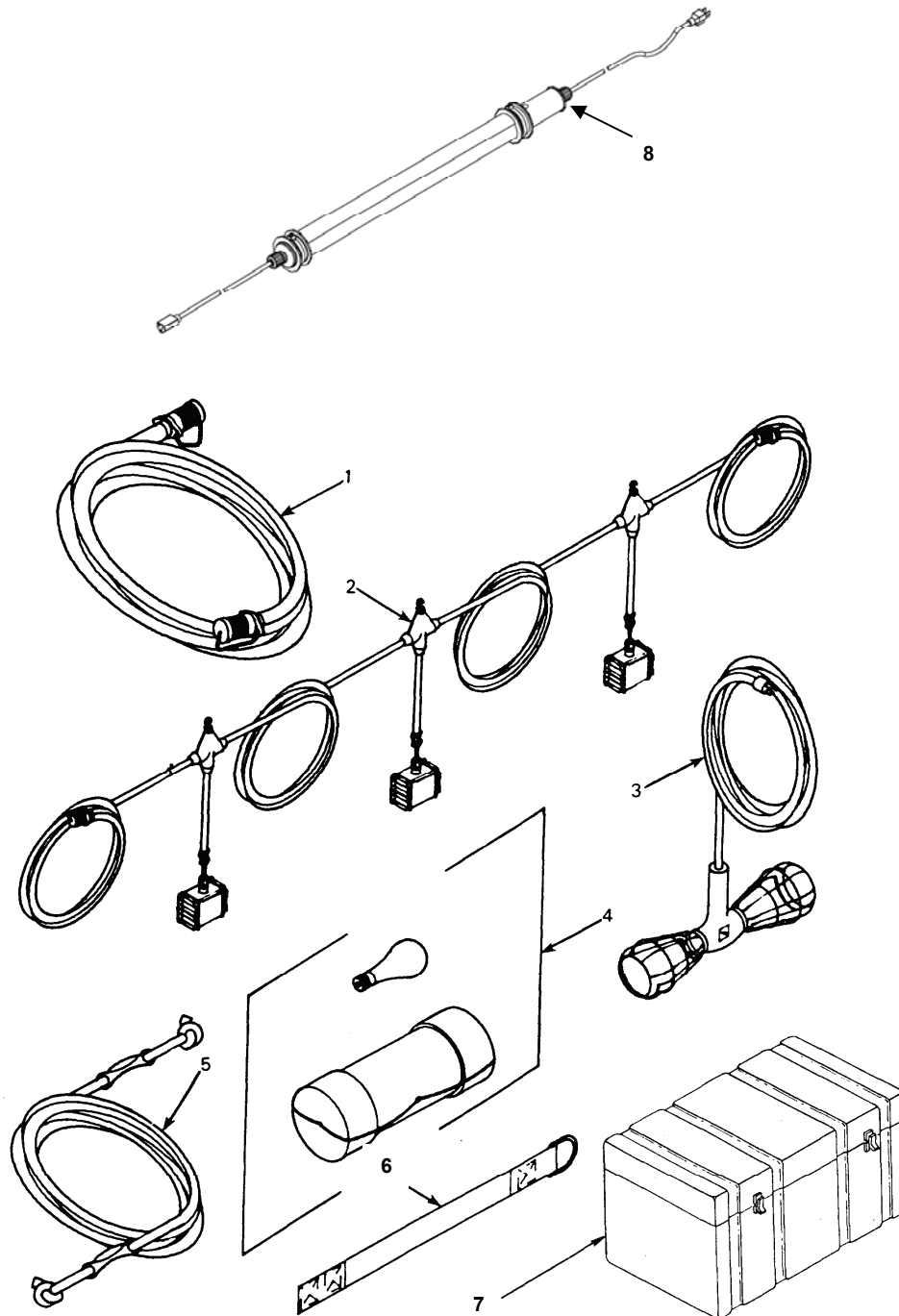

Figure 7. Electrical Utility Kit Assembly, M46.

Auxiliary Equipment

User requirements will periodically vary according to the field situation and extra DISE or PDISE components may be required. The optional items listed below may be used to tailor the DISE and PDISE systems to your field's requirements:

- (1) Branch circuit cable, 8ft (2.4 m), 20-amp, 3-pin
- (2) Branch circuit cable, 16 ft (4.9 m), 20-amp, 3-pin
- (3) Branch circuit cable, 24 ft (7.3 m), 20-amp, 3-pin
- (4) Cable carrying straps
- (5) Cable securing straps
- (6) Container, transit and storage
- (7) Duplex receptacle, 120 V, 20 amp
- (8) Extension cable, 3.5 ft (1.1 m), 20-amp, 3-pin
- (9) Extension cable, 15 ft (4.6 m), 20-amp, 3-pin
- (10) Extension cable, 25 ft (7.6 m), 20-amp 3-pin
- (11) Extension cable, 50 ft (15.2 m), 20-amp, 3-pin
- (12) Fluorescent light, 120 V, single tube
- (13) Container, light bulb kit, 40 W, 2-bulb
- (14) Pigtail cable, 4 ft (1.2 m), 40/60-amp, 5-pin
- (15) Pigtail cable, 4 ft (1.2 m), 60-amp, 4-pin
- (16) Pigtail cable, 4 ft (1.2 m), 100-amp, 8-pin
- (17) Pigtail cable, 4 ft (1.2 m), 200-amp, 8-pin
- (18) Service/feeder cable, 25 ft (7.6 m), 40/60-amp, 5-pin
- (19) Service/feeder cable, 25 ft (7.6 m), 200-amp, 8-pin
- (20) Service/feeder cable, 50 ft (15.2 m), 40/60-amp, 5-pin
- (21) Service/feeder cable, 50 ft (15.2 m), 60-amp, 4-pin
- (22) Service/feeder cable, 50 ft (15.2 m), 100-amp, 8-pin
- (23) Service feeder cable, 100 ft (30.4 m), 40/60-amp, 5-pin
- (24) Service/feeder cable, 100 ft (30.4 m), 60-amp, 4-pin
- (25) Universal adapter
- (26) Utility light, 120 V, dual socket, incandescent
- (27) Utility light, 120 V, 36' fluorescent
- (28) Interface cable, 40/60-amp, 5-ton expanded van
- (29) Interface cable, 20-amp, general illumination light set
- (30) Cable carrying strap (double), 200-amp

DIFFERENCE BETWEEN MODELS.

The major difference between the DISE and PDISE systems are:

- (1) The DISE models (M40, M60, M100 and M200) use *thermal*-magnetic circuit breakers while the PDISE models (M40 A/P, M60 A/P, M100 A/P and M200 A/P) use *hydraulic*-magnetic circuit breakers.
- (2) The DISE models use one length of wire for each model inside the enclosure assembly while the PDISE models use different lengths of wire due to bus bar location and type of circuit breaker.
- (3) The DISE models have ground fault circuit interruption while the PDISE models do not use the ground fault circuit interruption circuit breaker.
- (4) The inside covers for DISE models are designed differently from PDISE models due to size of circuit breakers.

Three-Phase DISE and PDISE Equipment. The M40, M40A/P, M100, M100A/P, M200, and M200 A/P systems require a 3-phase electrical power source rated at 208VAC, 50/60 Hz for input power. These systems will provide 3-phase (208 VAC, 50/60 Hz) or single-phase (120 VAC, 50/60 Hz) electrical power, depending on which output receptacles are used. These three systems will interconnect to provide a 3-phase plus single-phase electrical network of up to 72 kW total capacity.

Single-Phase DISE and PDISE Equipment. The M60 and M60 A/P systems requires a single-phase electrical power source rated at 120 V ac, 50/60 Hz, for input power. This system will provide only single-phase (120 VAC, 50/60 Hz) electrical power at the output receptacles.

Electrical Utility Assembly. The M46 system connects to the M60 system outputs or to the single-phase outputs of the 3-phase systems (M40, M40 A/P, M100, M100 A/P, M200 and M200 A/P). The M46 system consists of various electrical cables, lights for illumination, and standard household type duplex receptacles for plugging in electrical loads, not to exceed the rating of the circuit breaker.

The M46 maybe substituted with the 36' in. fluorescent light assembly and/or a larger container to accommodate its length.

COMMON FEATURES BETWEEN SETS**Feeder/Distribution Centers:**

- (a) Each center uses a 4-foot (1.2 m) pigtail cable to connect to the generator.
- (b) Each center is equipped with a master circuit breaker rated at the maximum permissible load.
- (c) Each center is equipped with phase indicator lights which indicate the presence of input power.
- (d) Each center is equipped with branch circuits that are individually protected with circuit breakers.

Cables:

- (a) Cables are equipped with at least one phase wire, one neutral wire, and one ground wire.
- (b) Cables are equipped with military standard connectors which mate according to amperage rating. Cables designed for different amperages will not connect.
- (c) Cables are equipped with covers to protect the connectors from moisture and dirt.

WARNING

High voltage is present in this system. DISE/PDISE supports equipment using 120/208 VAC. Do not rely on the color of the wire insulation for phase color-coding. The insulation on the wires inside the cable jacket may vary, depending on supplier. Wires will be color coded to designate the phases. If the wire color coding cannot be determined, notify next higher level of maintenance to perform continuity test. Perform a continuity test to verify correct phase designations in accordance with identified color.

- (d) Cable wires are color-coded as follows:

- 1 Phase A (L1)-Black
- 2 Phase B (L2)-Red
- 3 Phase C (L3)-Blue
- 4 Neutral N (LO)-White
- 5 Ground G-Green or bare wire

Systems:

All systems are designed to provide correct phase, neutral, and ground matching.

EQUIPMENT DATA.

Table 1 lists equipment data for each of the DISE and PDISE feeder/distribution centers.

Table 1. DISE AND PDISE FEEDER/DISTRIBUTION CENTERS

Item	System Model			
	200-amp Feeder Center	100-amp Feeder Center	40-amp Distribution Center	60-amp Distribution Center
Weight in pounds (kilograms)	130-140 ((59.0-63.5))	65-77 (29.5-4.9)	48-55 (21.8-5.0)	43-45 (19.5-20.4)
Length in inches (centimeters)	33.5 (85.09)	24.25 (61.59)	24.25 (61.59)	24.25 (61.59)
Width in inches (centimeters)	22.97 (58.34)	22.35 (58.03)	21.74 (55.20)	21.74 (55.20)
Height in inches (centimeters)	20.37 (51.74)	20.37 (51.74)	16.12 (40.94)	15.50 (39.37)
Frequency ratings (Hz)	50/60	50/60	50/60	50/60
Voltage ratings (V)	120/208	120/208	120/208	120
Number of phases	3	3	3	1
Maximum amperage/phase (amp) (M40,M60,M100,M200)	200 72	100 36	40 14.4	60 7.2
Maximum output load (kW)				
Input Connectors				
200-amp/8-pin/3-ph	1			
100-amp/8-pin/3-ph		1		
40-amp/5-pin/3-h			1	
60-amp/4-pin/1-ph				1
Output connectors				
100-amp/8-pin/3-ph	3	1		
40-amp/5-pin/3-ph		2	1	
60-amp/5-pin/3-ph	4	2		
60-amp/4-pin/1-ph				1
20-amp/3-pin/1-ph	1	2	12	6
Circuit breakers				
200-amp/3-ph	1			
100-amp/3-ph	3	1		
60-amp/3-ph	4	2		
40-amp/3-ph		2	1	
60-amp/1-ph				1
20-amp/1-ph			6	3
20-amp/1-ph/ground fault (M40,M60,M100,M200)	1	2	6	3
20-amp/1-ph (M40A/P, M200A/P M100A/P).	1	2	12	
Phase indicator lights	3	3	3	1

* Tables 2 and 3 list equipment data for the DISE and PDISE cables.

Table 2. DISE and PDISE Cable.

Cable Name	AMP Rating	No. of Pins/Sockets	No of Phase Wires	Cable Length ft (m)	Cable Weight lb. (kg)	Connector Diameter in (mm)	Cable Diameter in. (mm)
Pigtail	200	8	3	4 (1.2)	28 (12.7)	4.1 (10.4)	2.4 (61)
Pigtail	100	8	3	4 (1.2)	17 (7.7)	3.7 (94)	1.6 (41)
Pigtail*	60	5	3	4 (1.2)	5 (2.3)	2.7 (69)	1.3 (33)
Pigtail	60	4	1	4 (1.2)	4 (1.8)	2.7 (69)	1.1 (28)
Service/Feeder	200	8	3	25 (7.6)	136 (61.7)	4.1 (104)	2.4 (61)
Service/Feeder	100	8	3	50 (15.2)	100 (45.4)	3.7 (94)	1.6 (41)
Service/Feeder*	40/60	5	3	25 (7.6)	27 (12.3)	2.7 (69)	1.3 (33)
Service/Feeder*	40/60	5	3	50 (15.2)	53 (24.1)	2.7 (69)	1.3 (33)
Service/Feeder*	40/60	5	3	100 (30.5)	105 (47.7)	2.7 (69)	1.3 (33)
Service/Feeder	60	4	1	50 (15.2)	48 (21.8)	2.7 (69)	1.1 (28)
Service/Feeder	60	4	1	100 (30.5)	96 (43.6)	2.7 (69)	1.1 (28)
Extension	20	3	1	3.5 (1.1)	0.7 (0.3)	1.2 (31)	0.4 (10)
Extension	20	3	1	15 (4.6)	3 (1.4)	1.2 (31)	0.4 (10)
Extension	20	3	1	25 (7.6)	5 (2.3)	1.2 (31)	0.4 (10)

Table 2. DISE and PDISE Cables. (Con't)

Extension	20	3	1	50 (15.2)	10 (4.5)	1.2 (31)	0.4 (10)
Branch (1-drop)	20	3	1	8 (2.4)	2 (0.9)	1.2 (31)	0.4 (10)
Branch (2-drop)	20	3	1	16 (4.9)	4 (1.8)	1.2 (31)	0.4 (10)
Branch (3-drop)	20	3	1	24 (7.3)	6 (2.7)	1.2 (31)	1.2 (31)

NOTE

*These cables may be connected to the 40-amp or 60-amp, 5 pin-3 phase connectors.

Table 3. APPROXIMATE* VOLTAGE LOSSES AT RATED CURRENT

Rated Amperage /No. of Pins	Cable Length in Feet (Meters)					
	15 (4.6)	25 (7.6)	50 (15.2)	100 (30.5)	200 (61)	300 (91.4)
200-amp/8-pin cables	1 V	1.6 V	3.2 V	6.4 V	12.8 V	19.2 V
100-amp/8-pin cables	0.4 V	0.7 V	1.4 V	2.8 V	5.6 V	8.4 V
60-amp/5-pin cables	0.5 V	0.9 V	1.6 V	3.5 V	6.4 V	10.5 V
40-amp/5-pin cables	0.3V	0.6 V	1.1 V	2.3 V	4.4 V	6.9 V
60-amp/4-pin cables	0.5 V	0.9 V	1.7 V	3.4 V	6.8 V	10.2 V
20-amp/3-pin cables	1.1 V	1.8 V	3.6 V	7.2 V	14.4 V	21.6 V

EQUIPMENT CONFIGURATION

Single-Phase System:

The **M60 and M60 A/P** 60-amp, single phase electrical distribution system (See Figure 6) can be used as a stand-alone system with the following provisions:

- (a) The total load must not exceed 7.2 kW.
- (b) The generator selected must be capable of supporting the total load.
- (c) Individual branch circuit loads must not exceed 2.4 kW. Three of the six outputs, carrying a maximum load, can be used at the same time.

Three-Phase Systems:

1. **M200 and M200 A/P.** The 200-amp, 3-phase electrical feeder system (Figure 3) can be used as a stand-alone system with the following provisions:

- (a) The total load must not exceed 72 kW.
- (b) The generator selected must be capable of supporting the total load.
- (c) Individual branch circuit output loads must not exceed:
 - (1) 36 kW for the 100-amp, 3-phase branch circuits. Two of the three outputs, carrying maximum load, can be used at the same time.
 - (2) 21.6 kW for the 60-amp, 3-phase branch circuits. Three of the four outputs, carrying a maximum load, can be used at the same time.
 - (3) 2.4 kW for the 20-amp, single-phase branch circuit.

2. **M100 and M100 A/P.** The 100-amp, 3-phase electrical feeder system (Figure 4) can be used as a stand-alone system with the following provisions:

- (a) The total load must not exceed 36 kW.
- (b) The generator selected must be capable of supporting the total load.
- (c) Individual branch circuit output loads must not exceed:
 - (1) 36 kW for the 100-amp, 3-phase feed-through circuit. This uses the total system capacity and no other outputs can be used.
 - (2) 21.6 kW for the 60-amp, 3-phase branch circuits. Only one of the two outputs, carrying maximum load, can be used at the same time.
 - (3) 14.4 kW for the 40-amp, 3-phase branch circuits. Both outputs, carrying maximum load, can be used at the same time.
 - (4) 2.4 kW for the 20-amp, single-phase circuits. Both outputs, carrying maximum load, can be used at the same time.

-
3. **M40 and M40 A/P.** The 40-amp, 3-phase electrical distribution system (Figure 5) can be used as a stand-alone system with the following provisions:
- (a) The total load must not exceed 14.4 kW.
 - (b) The generator selected must be capable of supporting the total load.
 - (c) Individual branch circuit output loads must not exceed:
 - (1) 14.4 kW for the 40-amp, 3-phase feed-through circuit. This uses the total system capacity and no other outputs can be used.
 - (2) 2.4 kW for the 20-amp, single-phase branch circuits. Six of the twelve outputs, carrying maximum load, can be used at the same time.

M46 Electrical Utility Assembly. The M46 (Figure 7) can be used with any DISE/PDISE system to provide the user with lighting and 120 VAC duplex receptacle outlets.

Networking. Figure 8 is an example of one possible network arrangement. The 3-phase systems are used for networking with the following provisions:

- (a) The total load must not exceed the capacity of the largest distribution center connected between the generator and the rest of the network.
- (b) The generator selected must be capable of supporting the total load.
- (c) Individual branch systems must not exceed the capacity of the branch distribution center.

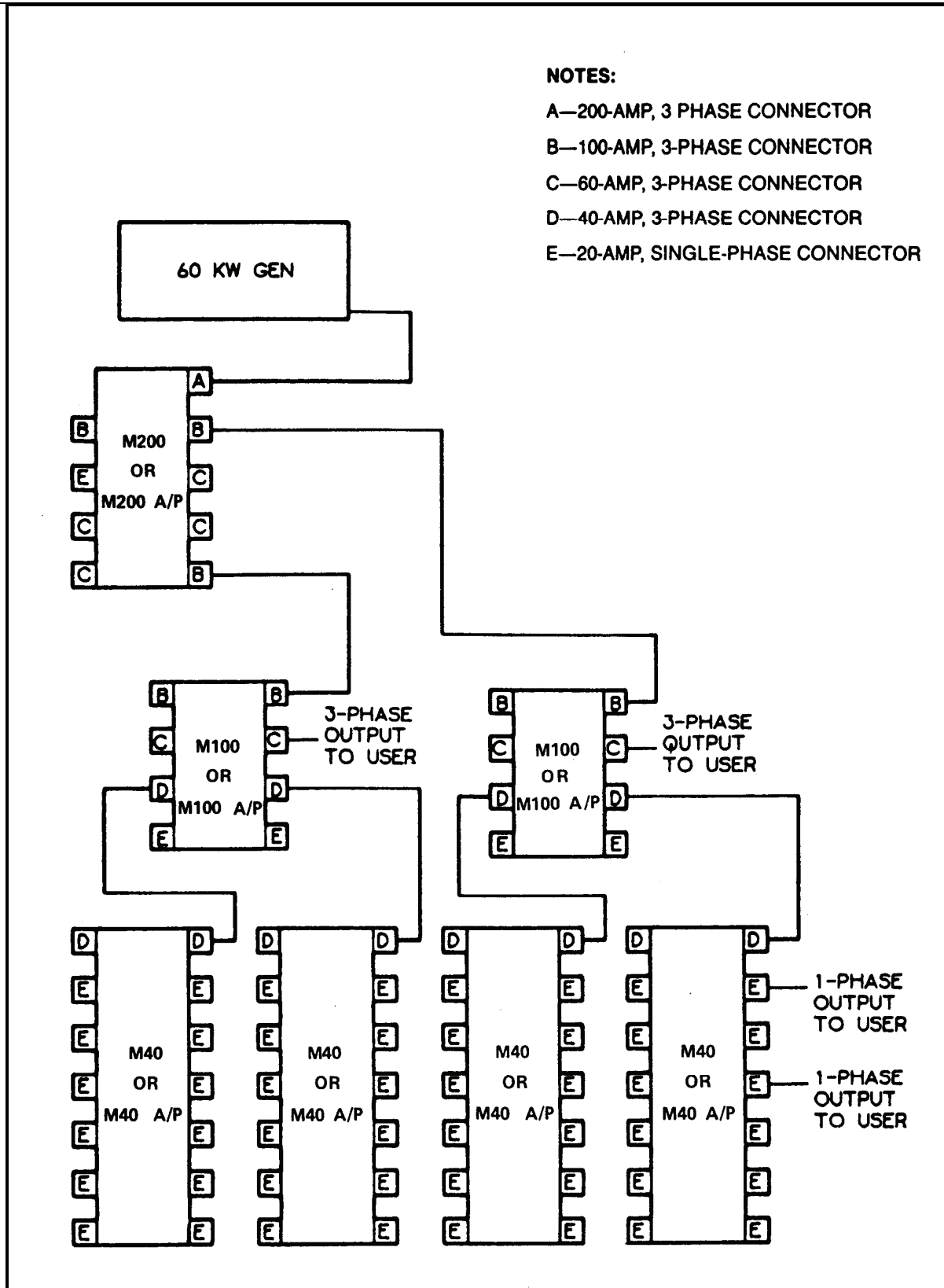

Figure 8. Example of Network Arrangement.

Generator –DISE/PDISE Configuration. Figure 9 is a list of examples for pairing generator sets with equipment. Refer to FM 20-31, Electrical Power Generation in the Field, for generator selection.

Generator KW	M200/ M200A/P	M100/ M100A/P	M40/ M40A/P	M60/ M60A/P	M46	Phase
5				1	3	1
10				1	3	1
10			1		6	3
15				3	9	1
15			1		6	3
30			2		12	3
30		1	1		6	3
60		2	2		12	3
60	1	2	2		12	3
100		3	6		36	3
100	2	4	8		48	3
200	3	6	12		72	3

Figure 9. Pairing of Gen Set with Equipment

PRINCIPLES OF OPERATION.

The generator supplies electrical power to the DISE and PDISE systems. The DISE and PDISE systems distribute electrical power through circuit breakers and cables to the user electrical equipment. The circuit breakers mounted in the feeder/distribution center protect system cables from excessive current flow.

END OF WORK PACKAGE

**OPERATOR AND FIELD MAINTENANCE MANUAL
DISE AND PDISE SYSTEMS
DESCRIPTION AND USE OF OPERATOR'S CONTROLS AND INDICATORS**

M200 DISE FEEDER CENTER AND M200 A/P PDISE FEEDER CENTER.

Main Circuit Breaker (CB1). This 3-phase circuit breaker (Figure 1, Item 1) for M200 and (Figure 1, Item 1) for A/P is in series between the 200-amp input connector and the bus bars. This circuit breaker prevents input power to the distribution center from exceeding a total current of 200 amps per phase (72 kW maximum load). This circuit breaker allows the operator to turn off power to all output circuit breakers.

CB4, CB5, and CB11 (100-amp, 3-Phase). Each 3-phase circuit breaker (Figure 1, Item 2) for M200 and (Figure 2, Item 2) for M200 A/P is in series between the bus bars and a 100-amp output connector. These circuit breakers prevent output power to the connectors from exceeding a current of 100 amps per phase (36 kW maximum load). These circuit breakers allow the operator to turn off power to the load circuits.

CB7, CB8, CB9, and C10 (60-amp, 3-Phase). Each 3-phase circuit breaker (Figure 1, Item 3) for M200 and (Figure 2, Item 3) for M200 A/P is in series between the bus bars and a 60-amp output connector. These circuit breakers prevent output power to the connectors from exceeding a current of 60 amps per phase (21.6 kW maximum load). These circuit breakers allow the operator to turn off power to the load circuits.

CB6 (20 amps Ground Fault [GF], Single-Phase). This circuit breaker (Figure 1, Item 4) for M200 is in series between the bus bars and the 20-amp output connector. This circuit breaker prevents output power to the connector from exceeding a current of 20 amps (2.4 kW maximum load), allows the operator to turn off power to the load, and also interrupts the circuits when a current flow occurs in the ground wire.

CB6 (20-amp, Single-Phase). This single-phase circuit breaker (Figure 2, Item 4) for M200 A/P is in series between the bus bars and a 20-amp output connector. This circuit breaker prevents output power to the connector from exceeding a current of 20 amps per phase (2.4 kW maximum load). This circuit breaker also allows the operator to turn off to the load circuit.

Ground Fault Test Switch. This switch (Figure 1, Item 5) for M200 tests the ground fault sensor (trip indication) for the 20A GF circuit breaker. The M200 A/P does not have a ground fault circuit.

L1, L2, and L3 Phase Indicator Lights. These lights (Figure 1, Item 6) for M200 and (Figure 2, Item 5) for M200 A/P are connected between neutral and each phase. When electrical power is being supplied to the feeder center, the lights will illuminate.

Identification Plates. Figure 1 and 2 shows the location of various data plates on the Control panel of M200 equipment. Figure 10 shows the location of the cable connections for the M200 equipment. Figure 9 shows a ground fault test record which is located on the right side of the control panel on all DISE feeder/distribution centers.

1. IF CIRCUIT BREAKER IS IN TRIPPED POSITION, IT INDICATES THAT BREAKER HAS BEEN SUBJECTED TO AN OVERLOAD CONDITION. **WAIT TWO MINUTES** BEFORE RESETTING BREAKER. TO RESET BREAKER, IT MUST BE PUSHED TO "OFF" POSITION BEFORE TURNING TO "ON".
2. IF CIRCUIT BREAKER IS IN "OFF" POSITION, IT INDICATES THAT IT HAS NOT BEEN OPERATED OR HAS BEEN SUBJECTED TO SEVERE OVERLOAD.
3. IF BREAKER TRIPS AGAIN AFTER RESETTING, THE FAULT MUST BE CLEARED BEFORE SAFE OPERATION CAN BE RESUMED. IF NO FAULT IS DETECTED, CHECK OR REPLACE BREAKER.

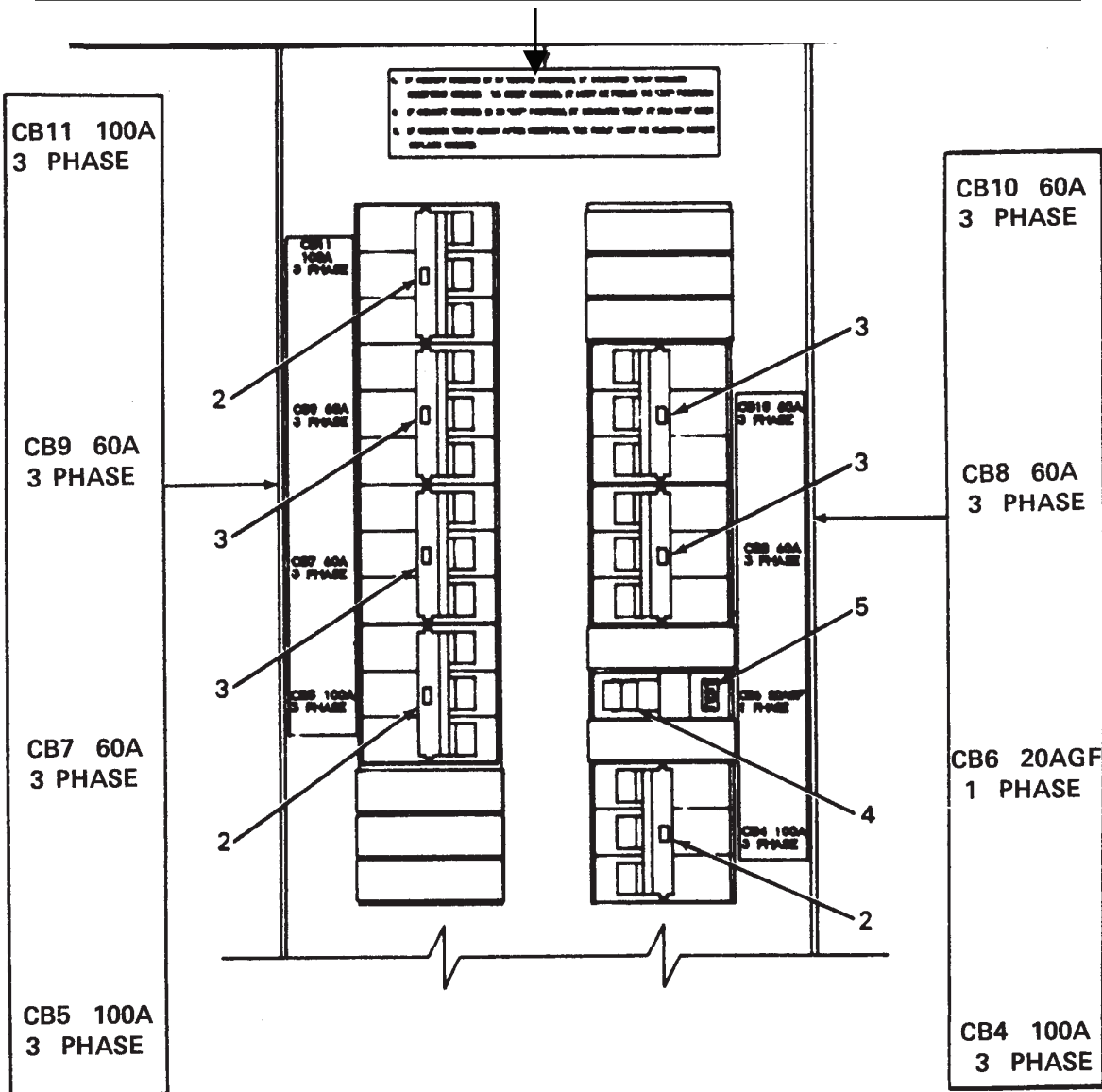

Figure 1. M200 (DISE) System Control Panel (1 of 2)

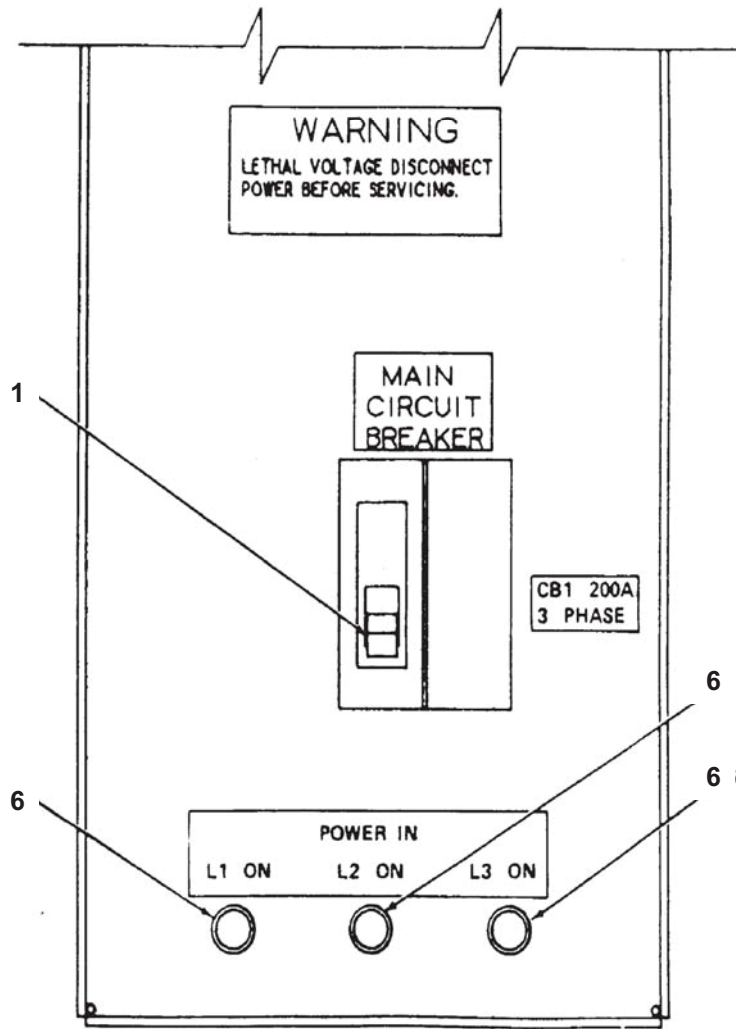

Figure 1. M200 (DISE) System Control Panel (2 of 2)

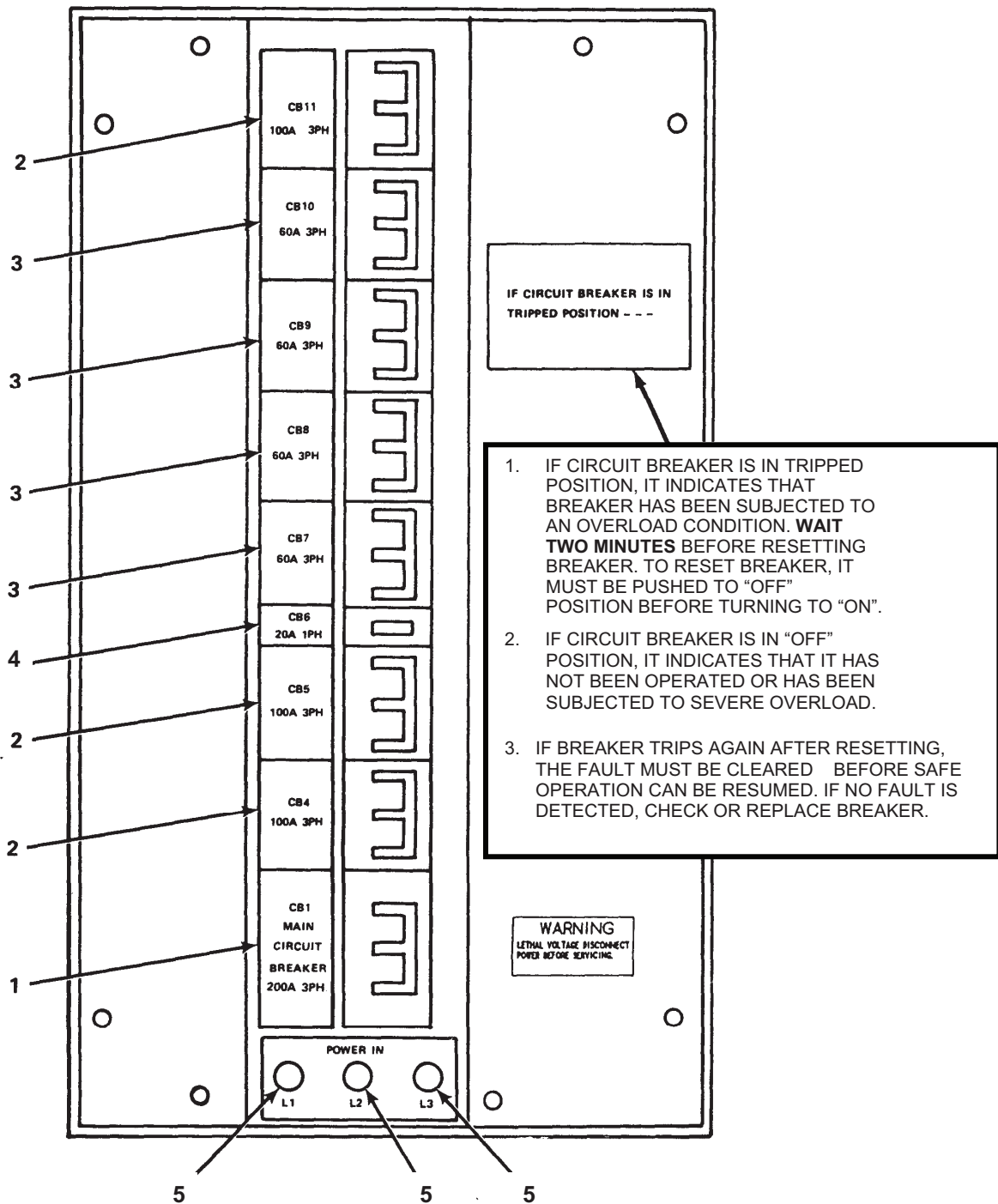

Figure 2. M200 A/P (PDISE) System Control Panel

M100 DISE FEEDER CENTER AND M100 A/P PDISE FEEDER CENTER.

Main Circuit Breaker CB1 (100-amp, 3-Phase). This 3-phase circuit breaker (Figure 3, Item 1) for M100 and (Figure 4, Item 1) for M100 A/P is in series between the 100-amp input connector and the bus bars. This circuit breaker prevents input power to the distribution center from exceeding a total current of 100 amps per phase (36 kW maximum load). This circuit breaker also allows the operator to turn off power to all output circuit breakers.

CB3 and CB6 (60-amp, 3-Phase). Each 3-phase circuit breaker (Figure 3, Item 2) for M100 and (Figure 4, Item 2) for M100 A/P is in series between the bus bars and a 60-amp output connector. These circuit breakers prevent output power to the connectors from exceeding a current of 60 amps per phase (21.6 kW maximum load). These circuit breakers also allow the operator to turn off power to the load circuits.

CB4 and CB5 (40-amp, 3-Phase). Each 3-phase circuit breaker (Figure 3, Item 3) for M100 and (Figure 4, Item 3) for M100 A/P is in series between the bus bars and a 40-amp output connector. These circuit breakers prevent output power to the connectors from exceeding a current of 40 amps per phase (14.4 kW maximum load). These circuit breakers allow the operator to turn off power to the load circuits.

CB7 and CB8 Ground Fault [GF], Single-Phase). Each single-phase circuit breaker (Figure 3, Item 4) for M100 is in series between the bus bars and a 20-amp output connector. These circuit breakers prevent output power to the connectors from exceeding a current of 20 amps (2.4 kW maximum load), allows the operator to turn power off to the load, and interrupt the circuit when a current flow occurs in the ground wire.

CB7 and CB8 (20-amp, Single-Phase). Each single-phase circuit breaker (Figure 4, Item 7) for M100 A/P is in series between the bus bars and a 20-amp output connector. These circuit breakers prevent output power to the connectors from exceeding a current of 20 amps per phase (2.4 kW maximum load). These circuit breakers also allow the operator to turn off to the load circuits.

Ground Fault Test Switch. These switches (Figure 3, Item 5) for the M100 test the ground fault sensor (trip indication) for the 20A GF circuit breakers. The M100 A/P does **not** have a ground fault circuit.

L1, L2, and L3 Phase Indicator Lights. These lights (Figure 3, Item 6) for M100 and (Figure 4, Item 6) for M100 A/P are connected between neutral and each phase. When electrical power is being supplied to the feeder center, the lights will illuminate.

Identification Plates. Figure 3 and 4 shows the location of various data plates on the control panel of M100 equipment. Figure 11 shows the location of the cable connection for the M100 equipment. Figure 9 shows a ground fault test record which is located on the right side of the control panel on all DISE feeder/distribution centers.

1. IF CIRCUIT BREAKER IS IN TRIPPED POSITION, IT INDICATES THAT BREAKER HAS BEEN SUBJECTED TO AN OVERLOAD CONDITION. **WAIT TWO MINUTES** BEFORE RESETTING BREAKER. TO RESET BREAKER, IT MUST BE PUSHED TO "OFF" POSITION BEFORE TURNING TO "ON".
2. IF CIRCUIT BREAKER IS IN "OFF" POSITION, IT INDICATES THAT IT HAS NOT BEEN OPERATED OR HAS BEEN SUBJECTED TO SEVERE OVERLOAD.
3. IF BREAKER TRIPS AGAIN AFTER RESETTING, THE FAULT MUST BE CLEARED BEFORE SAFE OPERATION CAN BE RESUMED. IF NO FAULT IS DETECTED, CHECK OR REPLACE BREAKER.

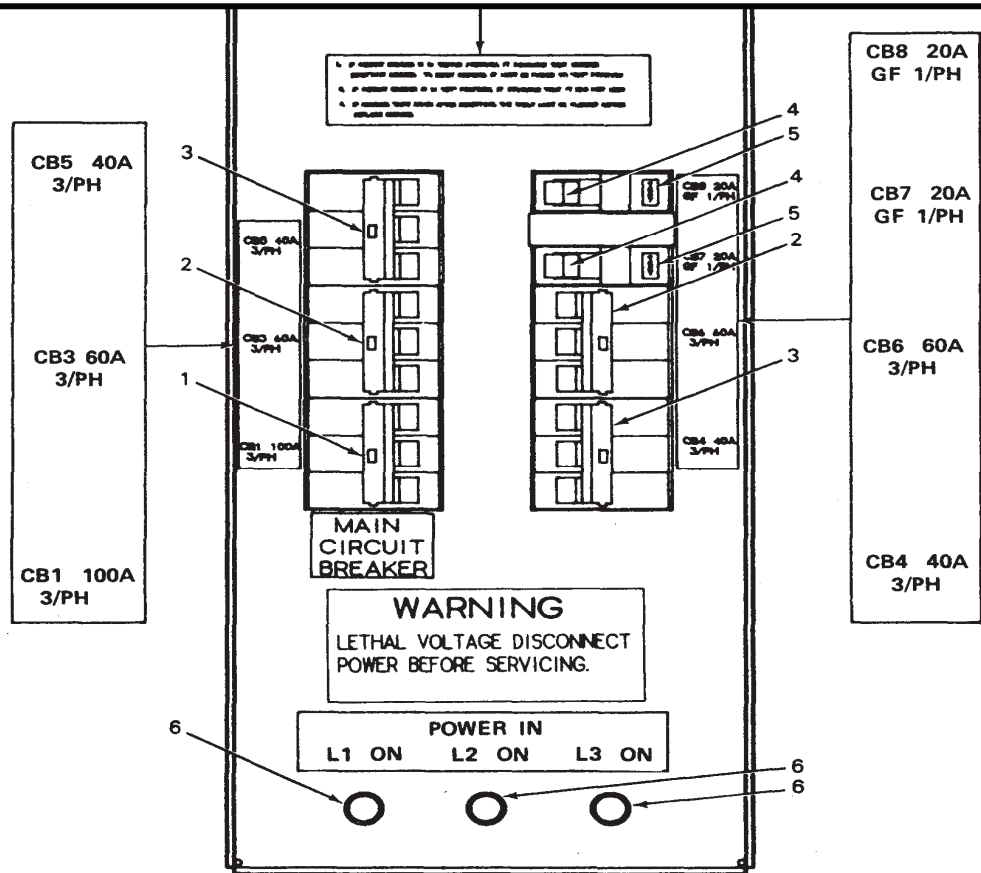

Figure 3. M100 (DISE) System Control Panel

1. IF CIRCUIT BREAKER IS IN TRIPPED POSITION, IT INDICATES THAT BREAKER HAS BEEN SUBJECTED TO AN OVERLOAD CONDITION. WAIT TWO MINUTES BEFORE RESETTING BREAKER. TO RESET BREAKER, IT MUST BE PUSHED TO "OFF" POSITION BEFORE TURNING TO "ON".
2. IF CIRCUIT BREAKER IS IN "OFF" POSITION, IT INDICATES THAT IT HAS NOT BEEN OPERATED OR HAS BEEN SUBJECTED TO SEVERE OVERLOAD.
3. IF BREAKER TRIPS AGAIN AFTER RESETTING, THE FAULT MUST BE CLEARED BEFORE SAFE OPERATION CAN BE RESUMED. IF NO FAULT IS DETECTED, CHECK OR REPLACE BREAKER.

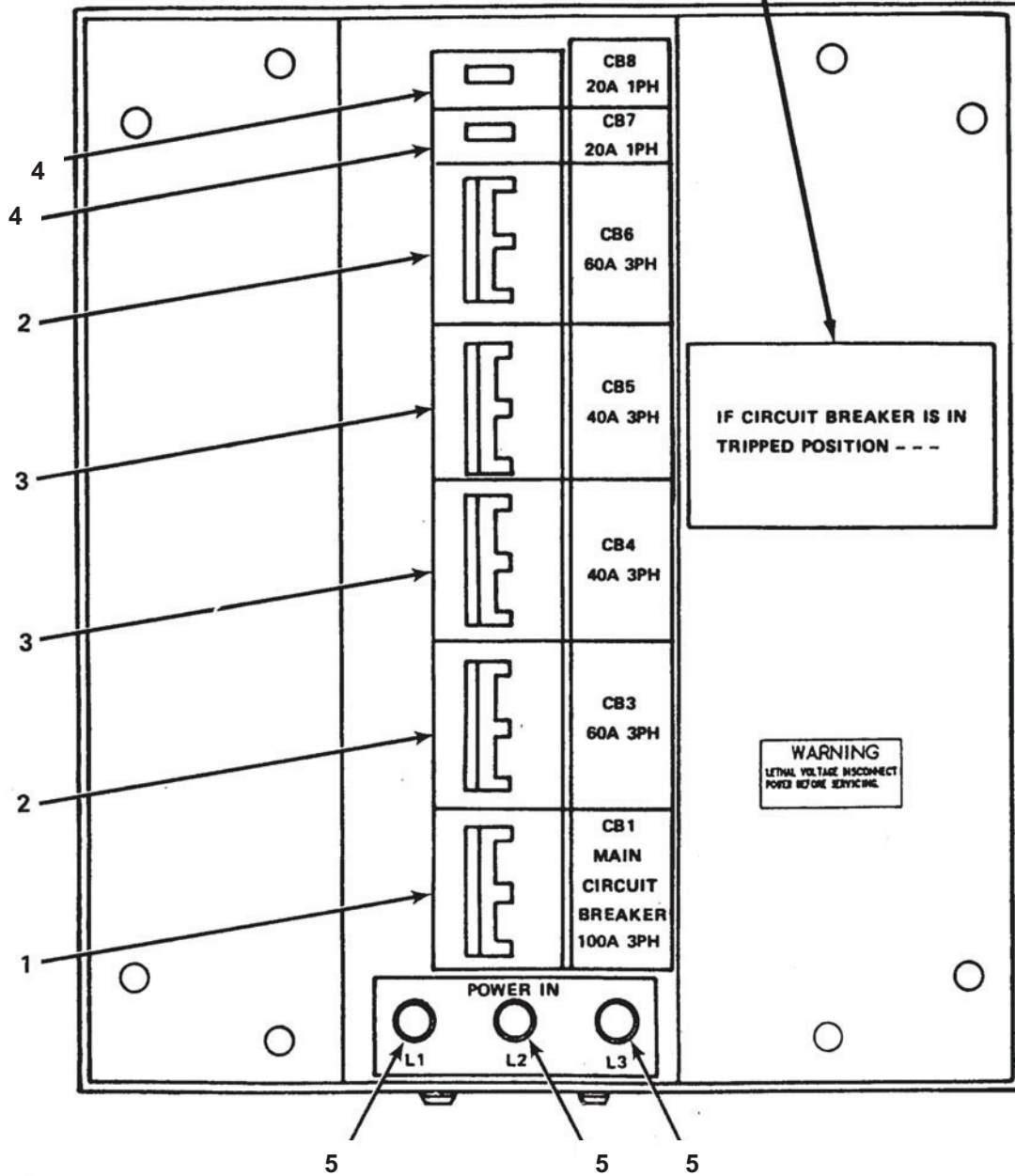

Figure 4. M100 A/P (PDISE) System Control Panel

M40 DISE DISTRIBUTION CENTER AND M40 A/P PDISE DISTRIBUTION CENTER.

Main Circuit Breaker CB1 (40-amp, 3-Phase). This 3-phase circuit breaker (Figure 5, Item 1) for the M40 and (Figure 6, Item 1) for M40 A/P is in series between the 40-amp input connector and the bus bars. This circuit breaker prevents input power to the distribution center from exceeding a total current of 40 amps per phase (14.4 kW maximum load). This circuit breaker allows the operator to turn off power to all output circuit breakers.

CB4, CB6, CB10, CB12, CB14 and CB14 (20-amp, Single-Phase). Each single-phase circuit breaker (Figure 5, Item 2) for M40 is in series between the bus bars and a 20-amp output connector. These circuit breakers prevent output power to the connectors from exceeding a current of 20 amps per phase (2.4 kW maximum load). These circuit breakers also allow the operator to turn off power to the load circuits.

CB3, CB5, CB7, CB9, CB11, and CB13 (20-amp Ground Fault [GF], Single-Phase). Each single-phase circuit breaker (Figure 5, Item 3) for the M40 is in series between the bus bars and a 20-amp output connector. These circuit breakers prevent output power to the connectors from exceeding a current of 20 amps (2.4 kW maximum load), allows the operator to turn power off to the load, and also interrupts the circuit when a current flow occurs in the ground wire.

CB3 through CB14 (20-amp, Single Phase). Each single-phase circuit breaker (Figure 6, Item 3) for M40 A/P is in series between the bus bars and a 20- amp output connector. These circuit breakers prevent output power to the connectors from exceeding a current of 20 amps per phase (2.4 kW maximum load). These circuit breakers also allow the operator to turn off to the load circuits.

Ground Fault Test Switch. These switches (Figure 5, Item 4) for M40 test the ground fault sensors (trip on) for the 20 AFG circuit breakers. The M40 A/P does not have a ground fault circuit.

L1, L2, and L3 Phase Indicator Lights. These lights (Figure 5, Item 5) for M40 and (Figure 2, Item 2) for M40 A/P are connected between neutral and each phase. When electrical power is being supplied to the distribution center, the lights will illuminate.

Identification Plates. Figure 5 and 6 shows the location of various data plates on the control panel of M40 equipment. Figure 12 shows the location of the cable connections for the M40 equipment. Figure 9 shows a ground fault test record which is located on the right side of the control panel on all DISE feeder/distribution centers.

1. IF CIRCUIT BREAKER IS IN TRIPPED POSITION, IT INDICATES THAT BREAKER HAS BEEN SUBJECTED TO AN OVERLOAD CONDITION. **WAIT TWO MINUTES** BEFORE RESETTNG BREAKER. TO RESET BREAKER, IT MUST BE PUSHED TO "OFF" POSITION BEFORE TURNING TO "ON".
2. IF CIRCUIT BREAKER IS IN "OFF" POSITION, IT INDICATES THAT IT HAS NOT BEEN OPERATED OR HAS BEEN SUBJECTED TO SEVERE OVERLOAD.
3. IF BREAKER TRIPS AGAIN AFTER RESETTNG, THE FAULT MUST BE CLEARED BEFORE SAFE OPERATION CAN BE RESUMED. IF NO FAULT IS DETECTED, CHECK OR REPLACE BREAKER.

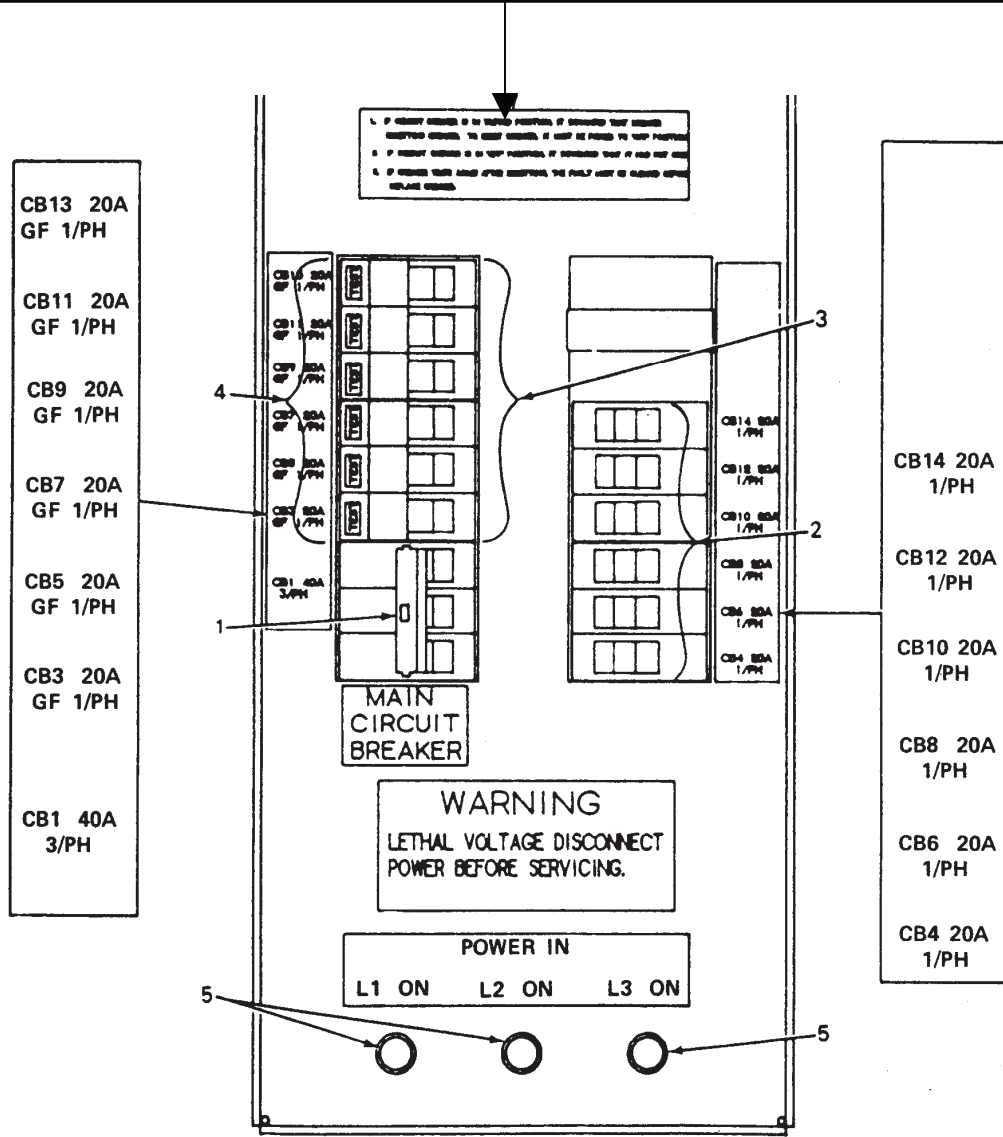

Figure 5. M40 (DISE) System Control Panel

1. IF CIRCUIT BREAKER IS IN TRIPPED POSITION, IT INDICATES THAT BREAKER HAS BEEN SUBJECTED TO AN OVERLOAD CONDITION. WAIT TWO MINUTES BEFORE RESETTING BREAKER. TO RESET BREAKER, IT MUST BE PUSHED TO "OFF" POSITION BEFORE TURNING TO "ON".
2. IF CIRCUIT BREAKER IS IN "OFF" POSITION, IT INDICATES THAT IT HAS NOT BEEN OPERATED OR HAS BEEN SUBJECTED TO SEVERE OVERLOAD.
3. IF BREAKER TRIPS AGAIN AFTER RESETTING, THE FAULT MUST BE CLEARED BEFORE SAFE OPERATION CAN BE RESUMED. IF NO FAULT IS DETECTED, CHECK OR REPLACE BREAKER.

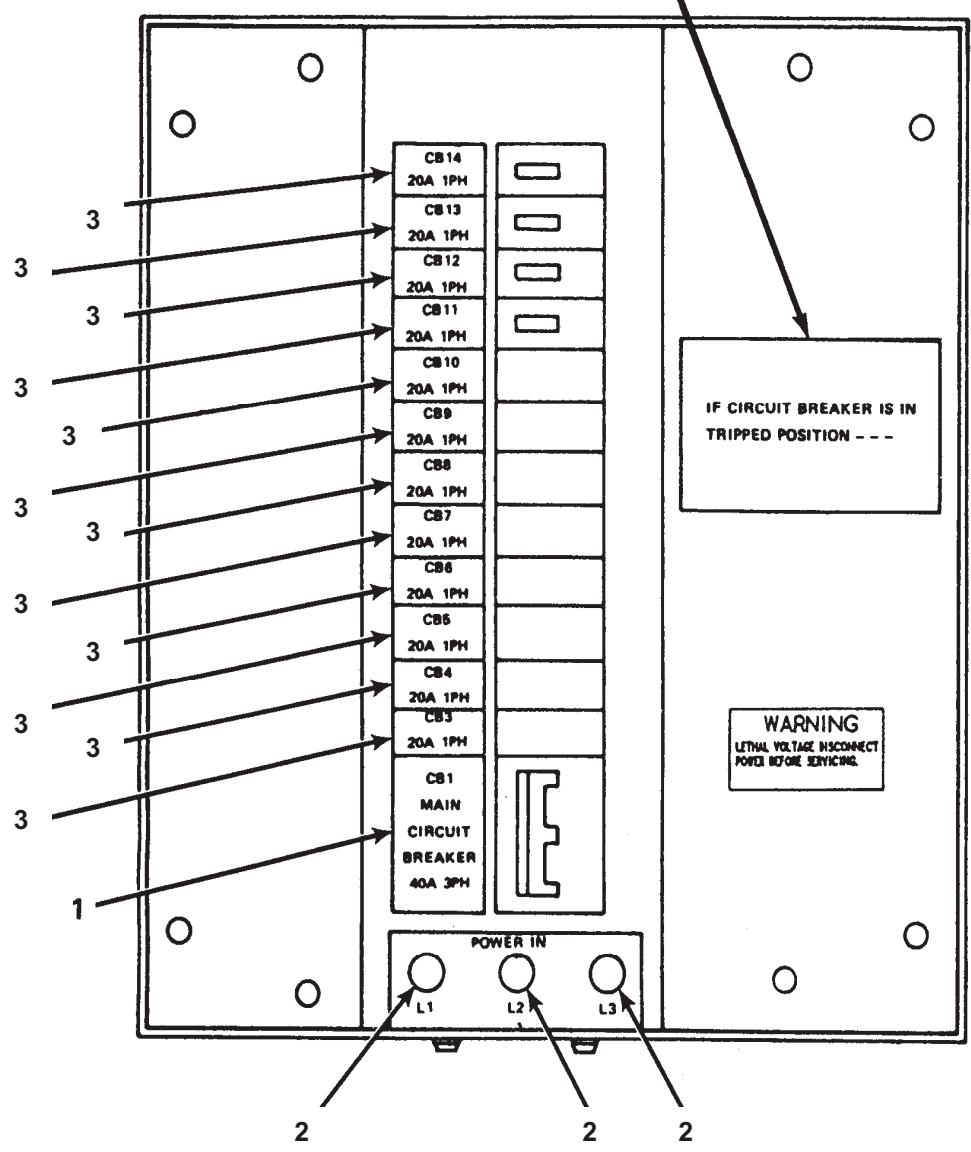

Figure 6. M40 A/P (PDISE) System Control Panel

M60 DISE DISTRIBUTION CENTER AND M60 A/P PDISE DISTRIBUTION CENTER.

Main Circuit Breaker CB1 (60-amp, Single Phase). This single phase circuit breaker (Figure 7, Item 1) for M60 and (Figure 8, Item 1) for M60 A/P is in series between the 60-amp input connector and the bus bars. This circuit breaker prevents input power to the distribution center from exceeding a total current of 60 amps (7.2 kW maximum load). This circuit breaker allows the operator to turn off power to all output circuit breakers.

CB4, CB6, CB8 (20-amp, Single-Phase). Each single-phase circuit breaker (Figure 7, Item 2) for M60 is in series between the bus bars and a 20-amp output connector. These circuit breakers prevent output power to the connector from exceeding a current of 20 amps (2.4 kW maximum load). These circuit breakers allow the operator to turn off power to the load circuits.

CB3, CB5, and CB7 (20-amp Ground Fault [GF], Single-Phase). Each single-phase circuit breaker (Figure 7, Item 3) for M60 is in series between the bus bars and a 20-amp output connector. These circuit breakers prevent output power to the connectors from exceeding a current of 20 amps per phase (2.4 kW maximum load), allows the operator to turn power off to the load, and interrupts the circuit when a current flow occurs in the ground wire.

GB3 through CB8 (20-amp, Single-Phase). Each single-phase circuit breaker (Figure 8, Item 3) for M60 A/P is in series between the bus bars and a 20-amp output connector. These circuit breakers prevent output power to the connectors from exceeding a current of 20 amps per phase (2.4 kW maximum load). These circuit breakers also allow the operator to turn power off to the load.

Ground Fault Test Switch. These switches (Figure 7, Item 4) for M60 test the ground fault sensors (trip indication) for the 20A GF circuit breakers. The M60 A/P does not have a ground fault circuit.

Power Indicator Light. This light (Figure 7, Item 5) for M60 and (Figure 8, Item 2) for M60 A/P is connected between neutral and the phase line. When electrical power is being supplied to the distribution center, the light will illuminate.

Identification Plates. Figure 7 and 8 shows the location of various data plates on the control panel of M60 equipment. Figure 13 shows the location of the cable connections for the M60 equipment. Figure 9 shows a ground fault test record which is located on the right side of the control panel on all DISE feeder/distribution centers.

1. IF CIRCUIT BREAKER IS IN TRIPPED POSITION, IT INDICATES THAT BREAKER HAS BEEN SUBJECTED TO AN OVERLOAD CONDITION. WAIT TWO MINUTES BEFORE RESETTNG BREAKER. TO RESET BREAKER, IT MUST BE PUSHED TO "OFF" POSITION BEFORE TURNING TO "ON".
2. IF CIRCUIT BREAKER IS IN "OFF" POSITION, IT INDICATES THAT IT HAS NOT BEEN OPERATED OR HAS BEEN SUBJECTED TO SEVERE OVERLOAD.
3. IF BREAKER TRIPS AGAIN AFTER RESETTNG, THE FAULT MUST BE CLEARED BEFORE SAFE OPERATION CAN BE RESUMED. IF NO FAULT IS DETECTED, CHECK OR REPLACE BREAKER.

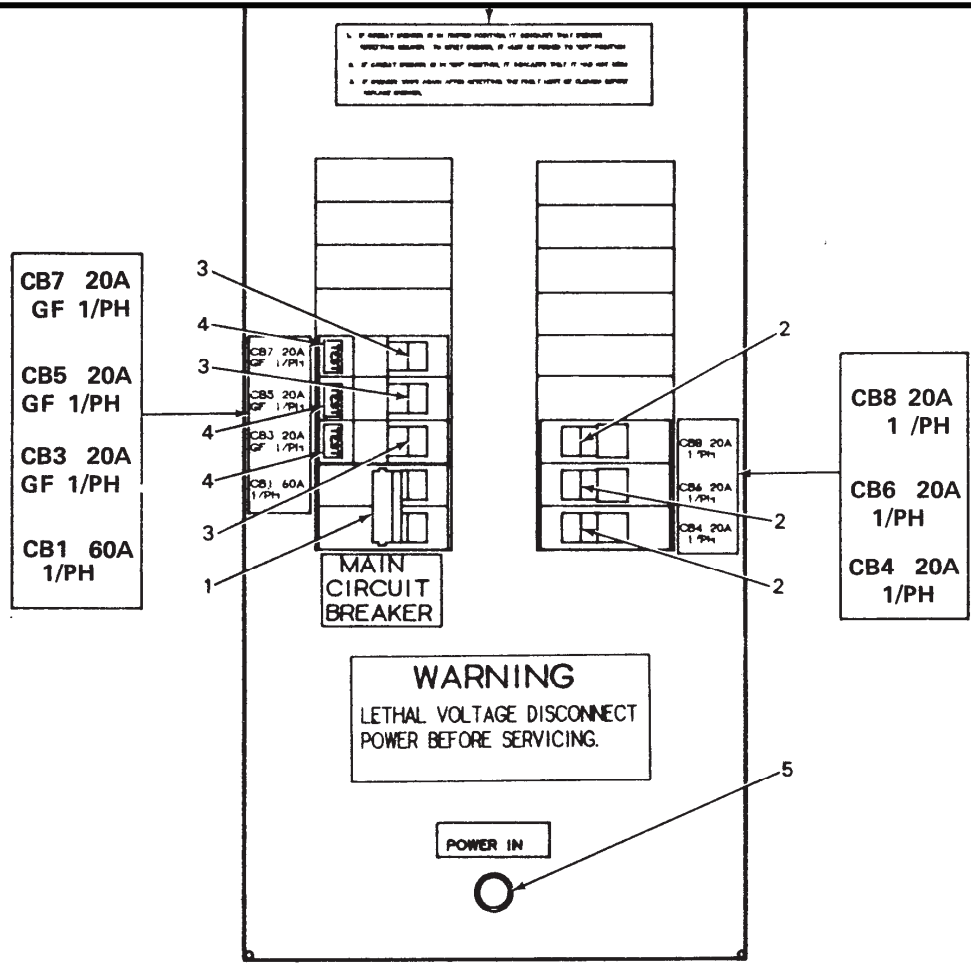

Figure 7. M60 (DISE) System Control Panel

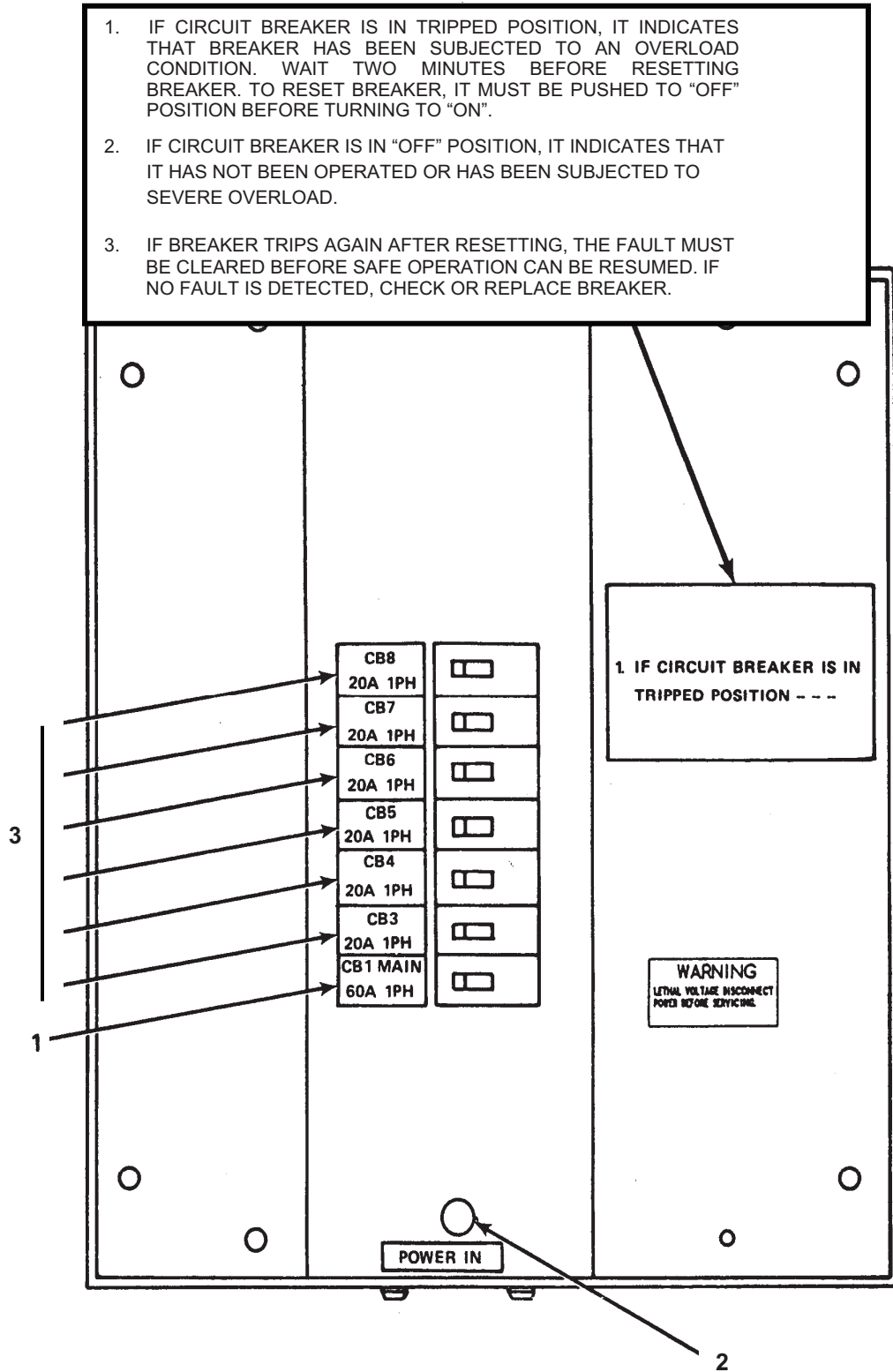

Figure 8. M60 A/P (PDISE) System Control Panel

TEST REMINDER

THE CIRCUIT BREAKERS ON THIS PANEL THAT CONTAIN A "PUSH TO TEST" BUTTON ARE OF THE "GROUND FAULT CIRCUIT INTERRUPTER" (GFCI) TYPE. FOR RELIABLE PROTECTION FROM ELECTRICAL SHOCK, EACH GFCI BREAKER SHOULD BE TESTED AT THE BEGINNING OF EACH SETUP AND AT MONTHLY INTERVALS THEREAFTER DURING CONTINUOUS OPERATIONS.

TO TEST THE GFCI BREAKER, PROCEED AS FOLLOWS:

1. CONNECT POWER SOURCE TO THE INPUT CONNECTOR.
2. TURN ON THE MAIN CIRCUIT BREAKER.
3. TURN ON THE GFCI CIRCUIT BREAKER.
4. PUSH THE "PUSH TO TEST BUTTON."
5. ENTER DATE TEST WAS PERFORMED AND INITIAL.
6. UNDER NOTES-RECORD ANY FAILURE AND ACTION TAKEN.
7. ALL ENTRIES SHOULD BE MADE WITH A MARKER THAT WILL PROVIDE A LEGIBLE RECORD AND THAT IS ERASABLE FOLLOWING THE TERMINATIONS OF AND OR COMPLETED MAINTENANCE ACTIONS.

	INIT	YEAR	DATE	INIT	YEAR	DATE	INIT	YEAR	DATE
JAN									
FEB									
MAR									
APR									
MAY									
JUN									
JUL									
AUG									
SEP									
OCT									
NOV									
DEC									

Figure 9. Ground Fault Test Record

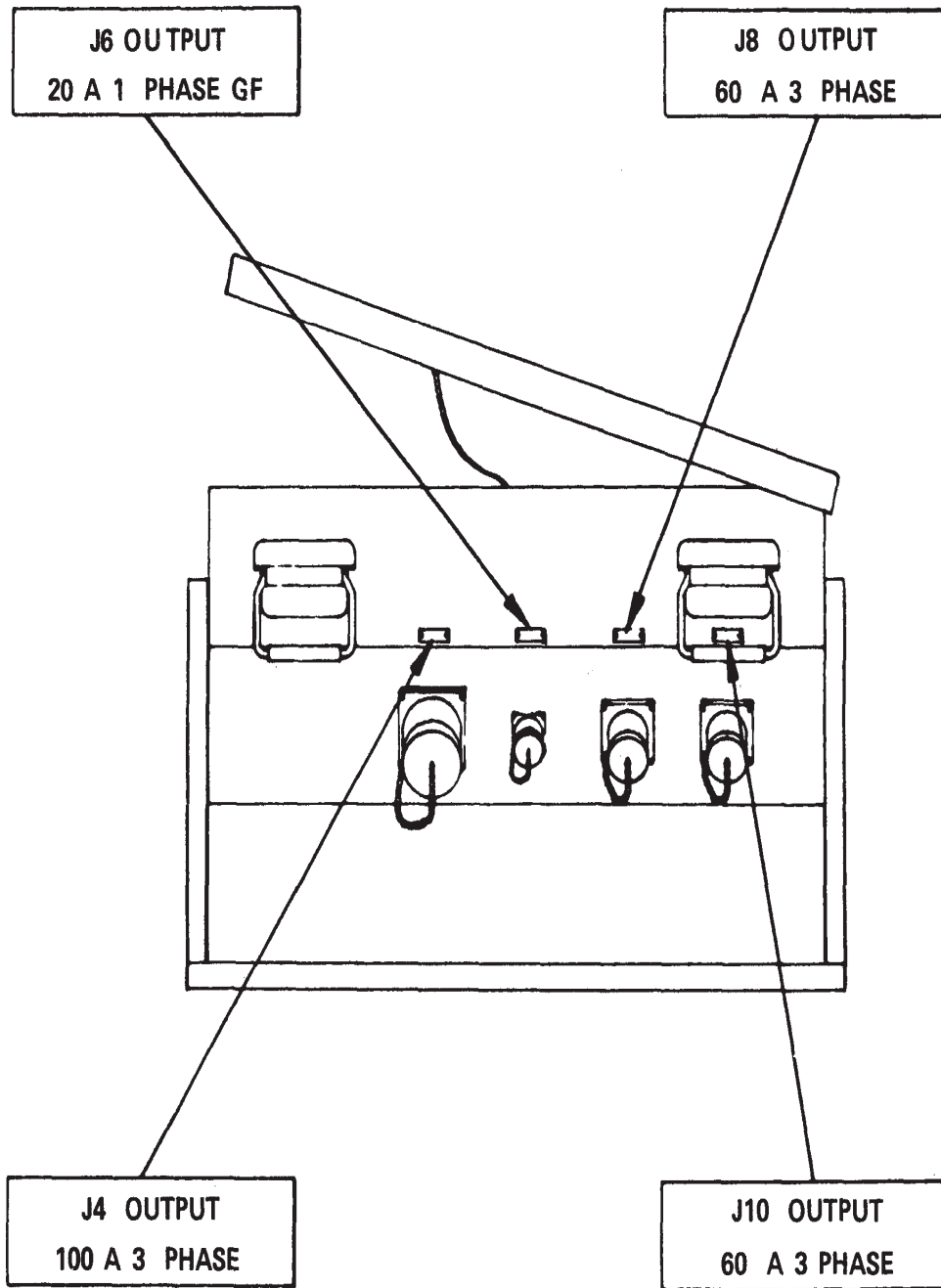

Figure 10. (Right Side View) M200 and M200 A/P Cable Connection Data Plates (1 of 2)

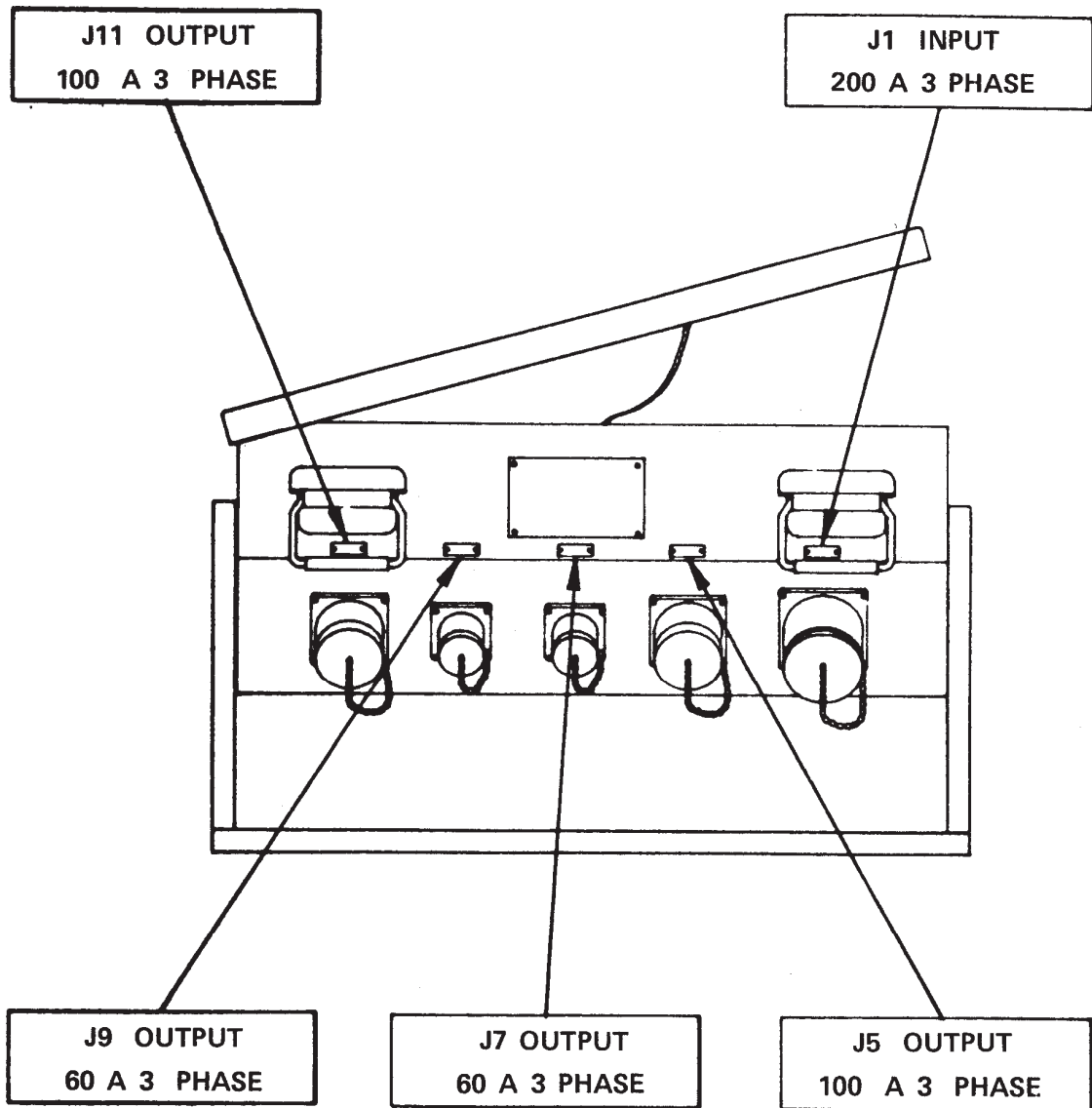

Figure 10. (Left Side View) M200 and M200 A/P Cable Connection Data Plates (2 of 2)

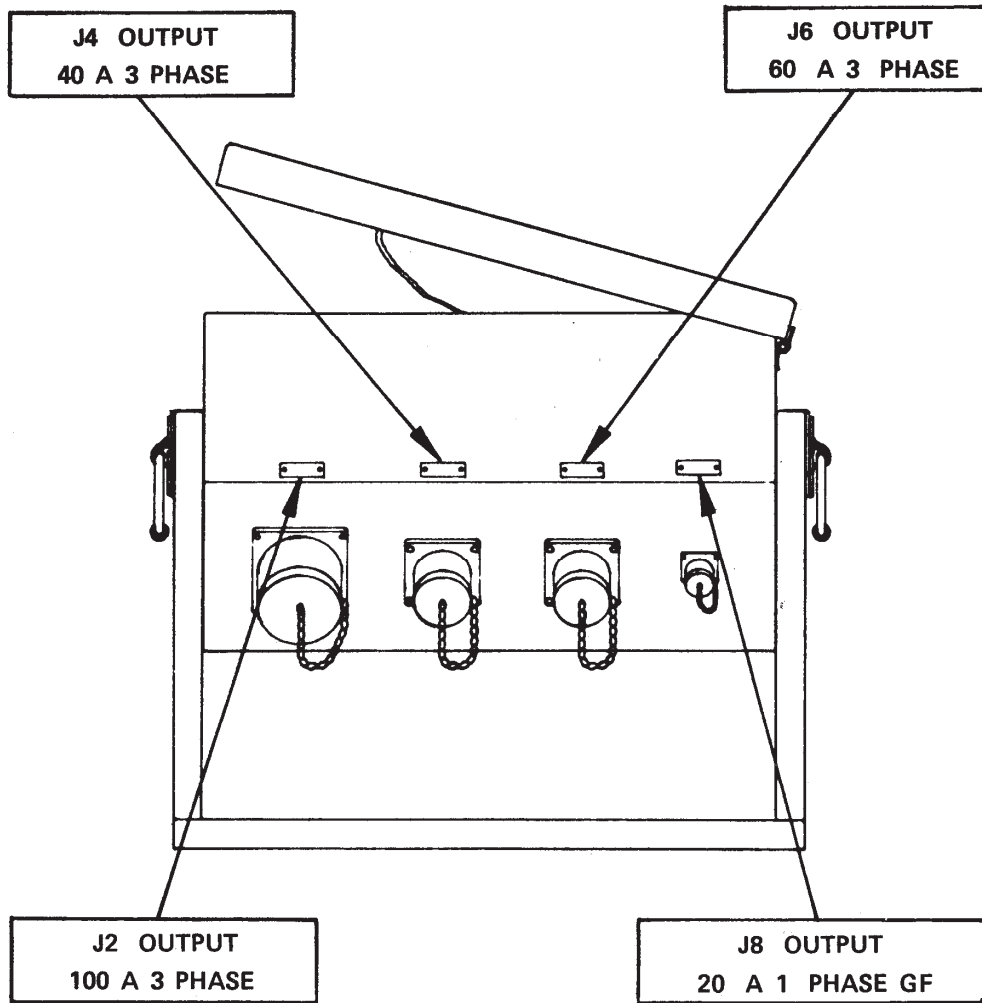

Figure 11. (Right Side View) M100 and M100 A/P Cable Connection Data Plates (1 of 2)

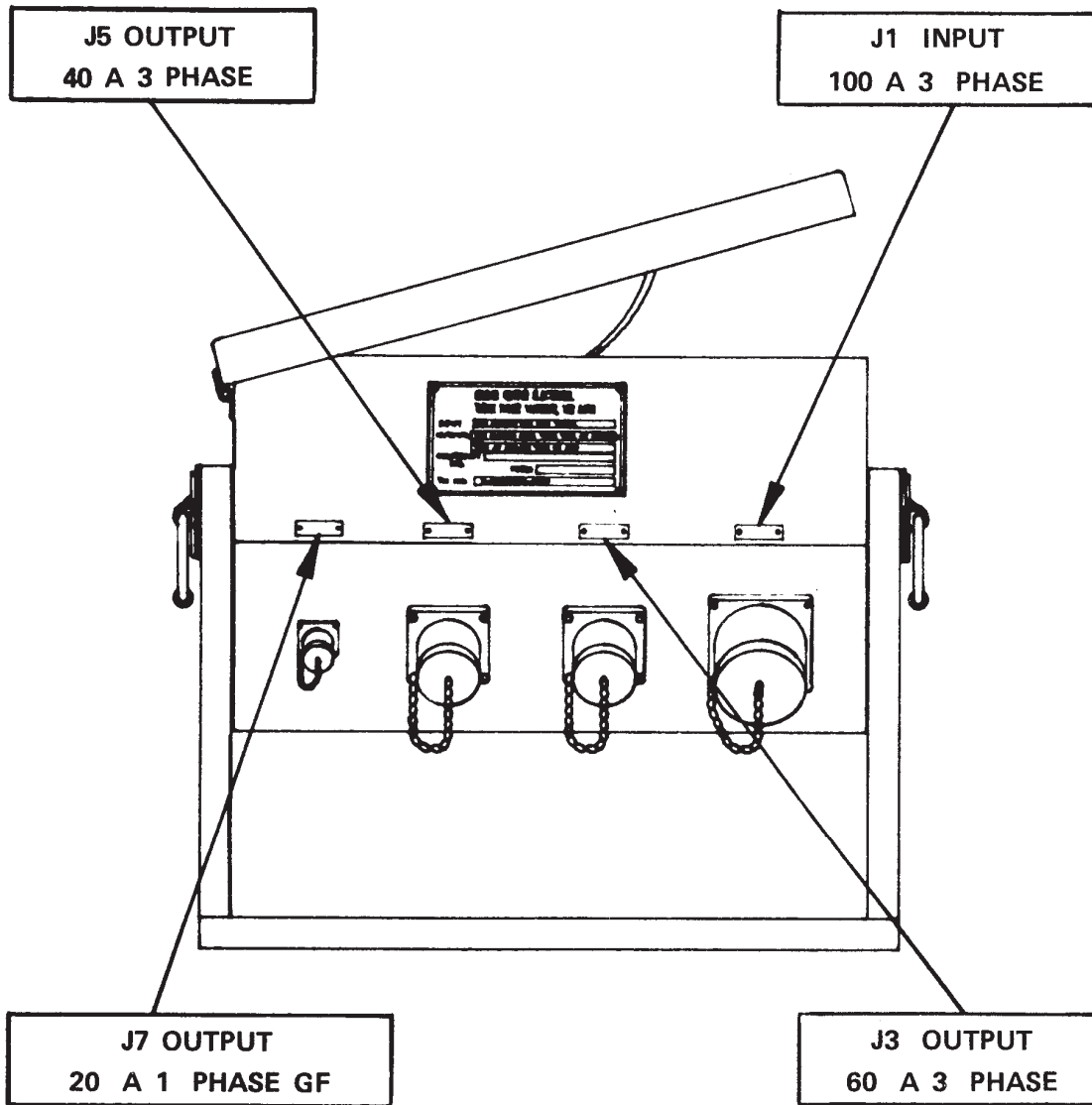

Figure 11. (Left View) M100 and M100 A/P Cable Connection Data Plates (2 of 2)

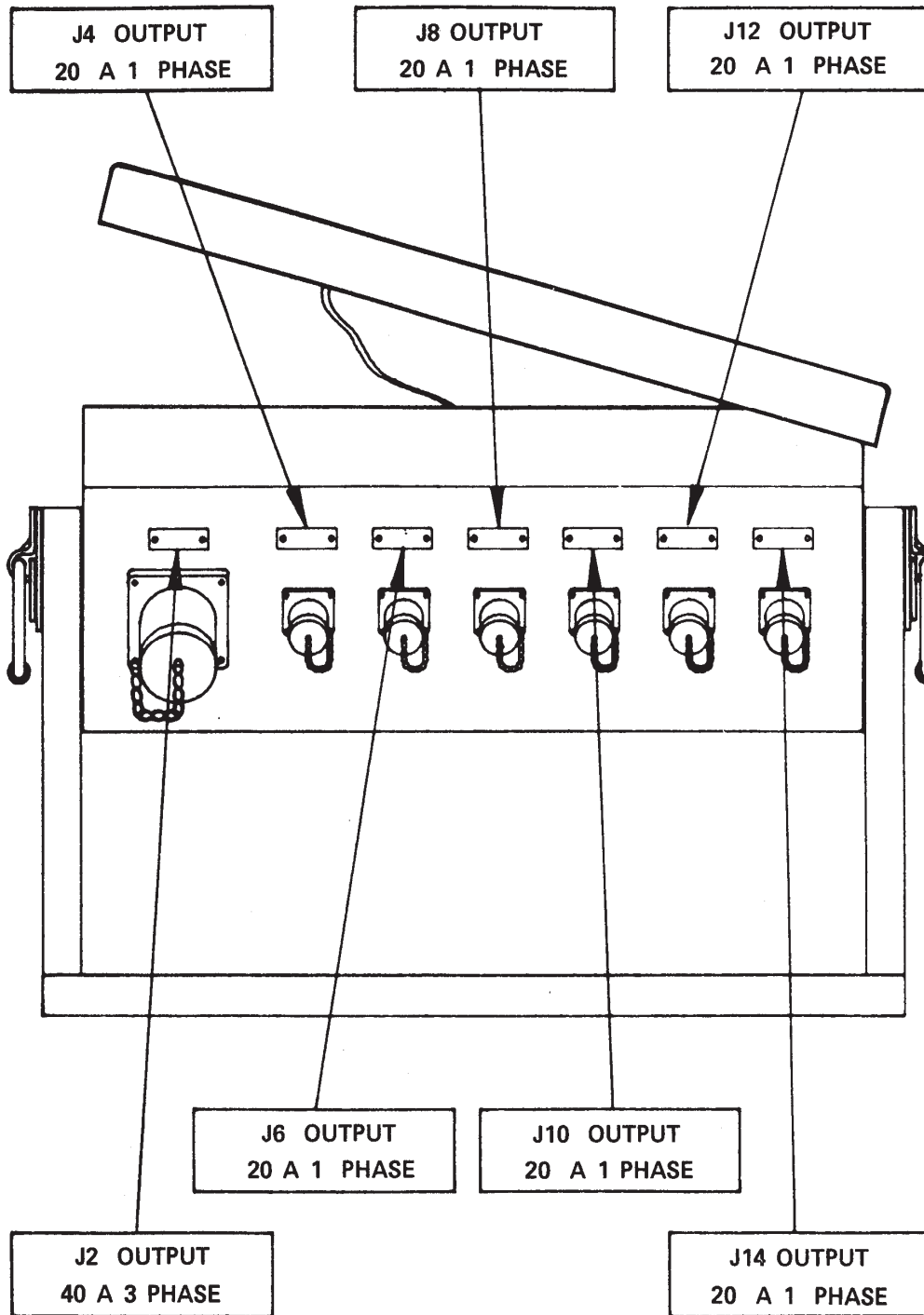

Figure 12. (Right View) M40 and M40 A/P Cable Connection Data Plates (1 of 2)

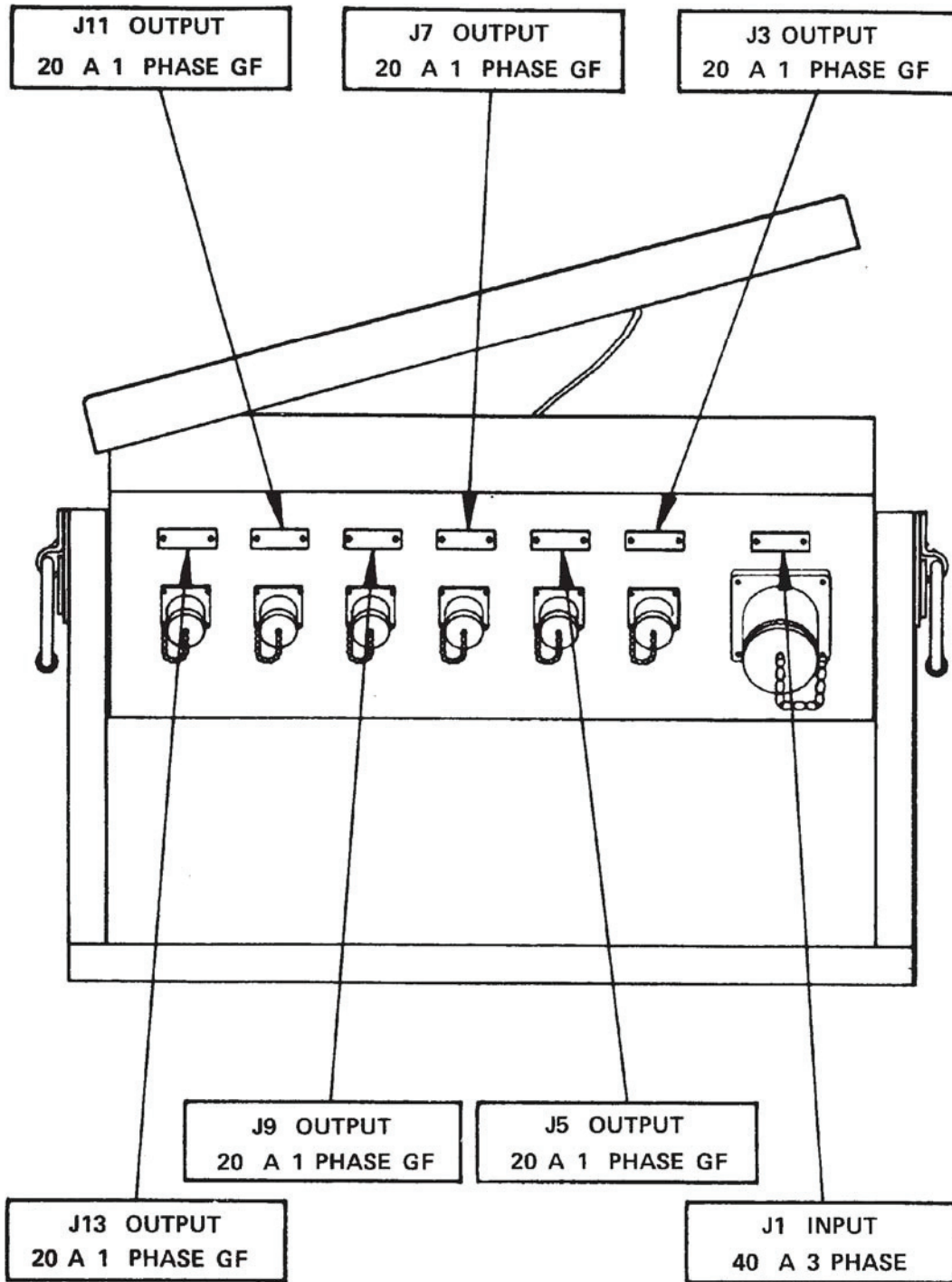

Figure 12. (Left View) M40 and M40 A/P Cable Connection Data Plates (2 of 2)

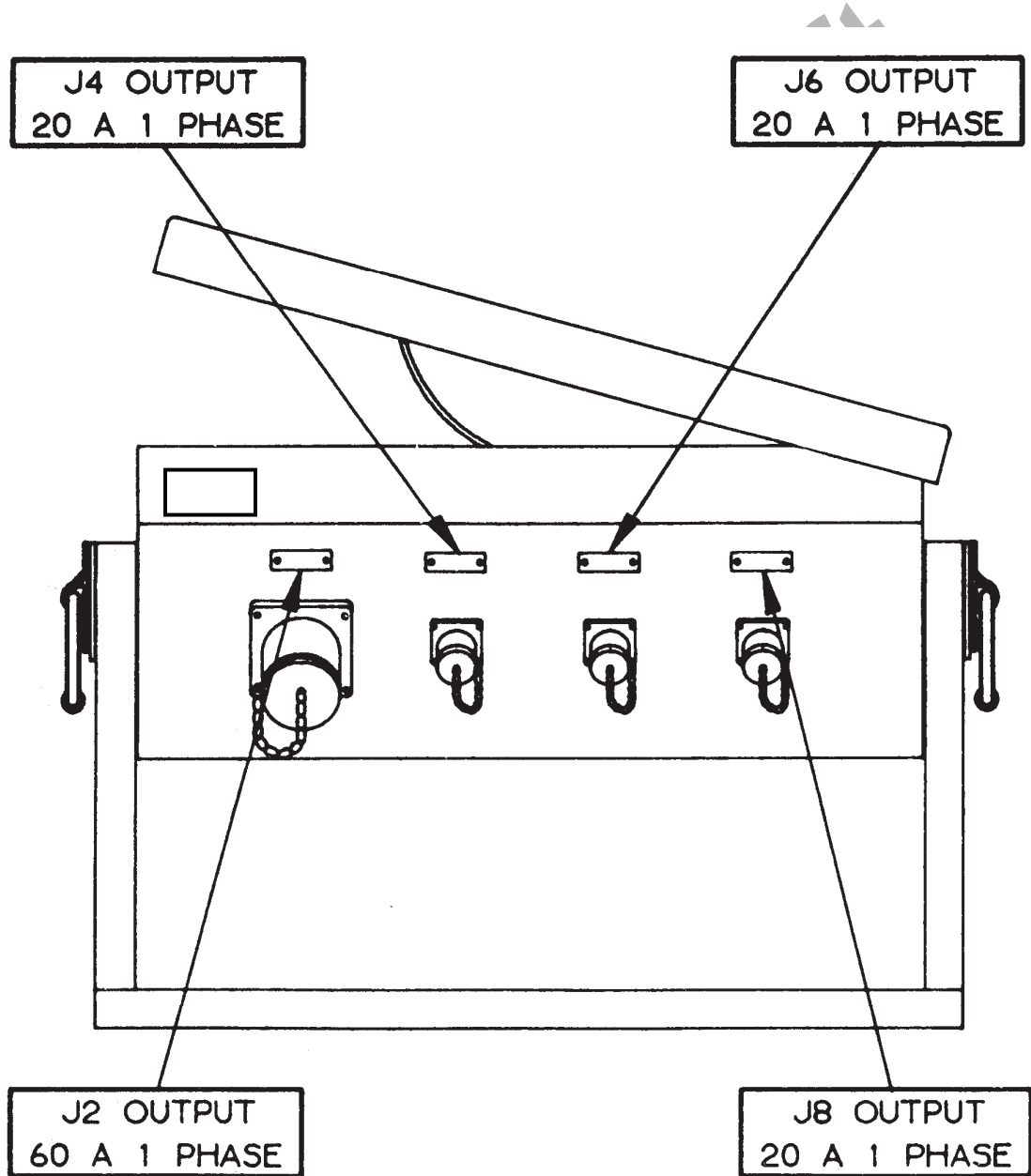

Figure 13. (Right View) M60 and M60 A/P Cable Connection Data Plates (1 of 2)

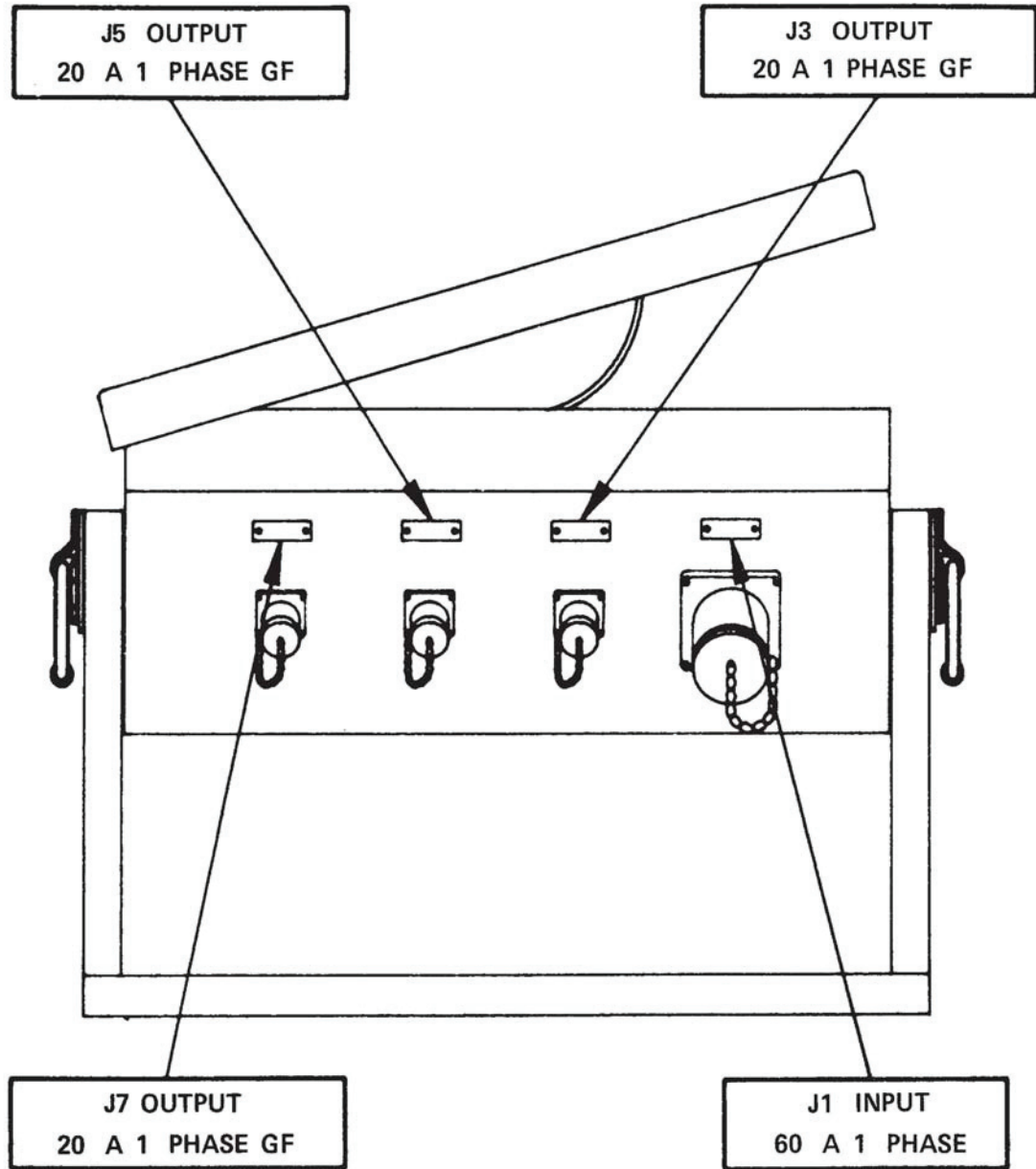

Figure 13. (Left View) M60 and M60 A/P Cable Connection Data Plates (2 of 2)

END OF WORK PACKAGE

Chapter 2

Operator Level Instructions

**OPERATOR AND FIELD MAINTENANCE MANUAL
DISE AND PDISE SYSTEMS
OPERATION UNDER USUAL CONDITIONS**

INITIAL SETUP:**Tools and Special Tools****Materials and Parts**

None

Personnel Required

One

ReferencesFM 20-31
DA Form 2404**Equipment Conditions**

PRELIMINARY SETUP**WARNING**

Components of this system are heavy and may be awkward to handle. Use correct lifting procedures and/or assistance from personnel to avoid injury.

NOTE

Considerations and calculations for field load equipment may be complicated. The Commander should appoint a qualified soldier to plan the power network. The soldier shall consult and plan the power network with personnel (MOS 52D) familiar with electrical power distribution principles and calculations when available to the field.

Assembly of Power Distribution Plan

1. Begin by creating an analysis of electrical equipment needs in the particular field application, starting with the consuming end of the system and work back to the power source.

The unit's TOE/MTOE will dictate the quantity and size of your generator set(s) and DISE or PDISE equipment, but various exercises may allow a selection of equipment to support the mission.

2. Determine special considerations for grounding and routing of cables. You should also know general locations of the power source and the vehicles, tents, communication vans, etc. that are being provided power.
3. Become familiar with *tactical* or other restrictions (if any) on locating the power source(s) relative to tents, shelters, and other power consuming equipment.
4. Prepare a power distribution plan based on the above analysis, to include wattage, amps, and type of power needed (single and three phase). Try to use the least amount of generators possible using FM 20-31 as a guide as well.

5. Draw up a “Power Distribution Plan” found in Figure 1 consisting of the following information:

- a. Location and description of all power consuming equipment.
- b. Voltage rating being used(single or three phase) and the number of receptacles (output) needed (plugs or MIL STD/universal adapter).
- c. Calculate “Rule of Thumb” formula for kilowatts or amperage using known (volts x amps) values to find watts. If power specifications are unknown, use estimated information.

When using the rule of thumb formula, the following points apply:

- Total Amps (I) will determine the proper DISE or PDISE feeder and/or distribution systems, the proper output connectors(s), and will be used for correct phase balancing discussed in this WP.
- Quantity (QTY) is the number of like items.
- Voltage (Volts): When the generator output voltage is set at 120/208 volts AC, 120 volts is single-phase (1) and 208 volts is three-phase (3). Single phase requires at least a two wire connection (one hot lead and one neutral lead). Three-phase requires at hot leads and one neutral lead).

Table 1. Rule of Thumb Formula

RESISTIVE LOADS (LIGHT OR HEAT)	INDUCTIVE LOADS MOTORS
KW = $\frac{QTY \times WATTS}{1000}$	KW = QTY X HP
I = $\frac{QTY \times WATTS}{VOLTS}$	I = QTY X AMPS
<u>NOTE</u> Use above formulas when watts and volts are given. Examples of resistive loads are light bulbs, heaters, coffee pots, etc.	<u>NOTE</u> Use above formulas when horsepower and amps are given. Examples of inductive loads are fans, drills, motors, etc.

NOTE

When volts and amps are known, use (volts x amps) to find watts. P = E x I

INDUCTIVE LOADS ONLY

- 1 HP = 1 KW
- 3/4 HP = .750 KW
- 1/2 HP = .500 KW
- 1/4 HP = .250 KW
- 1/8 HP = .125 KW

NOTE

DISE and PDISE can only be used with generators rated at 120/208 VAC.
All other ratings will require a different type of generator set.

d. Add up total amounts down at the bottom of the figure.

Area/Item	Required Receptacle		Total Kilowatts	Total Amps	
	120 V/1-ph Plug(s)	208 V/3-ph MIL STD/ Univ Adapter		1-ph	3-ph
Tent #1					
1.) Electric drill 120 V/800W	1		.800	6.6	
2.) Electric grinder 120 V/7.5 amps	1		.900	7.5	
3.) Sander 120 V/450W	1		.450	3.75	
4.) Radio set 120 V/180W	1		.180	1.5	
5.) Lights 120 V/60W ea	6		.360		
6.) Welder 208 V/1 1/2HP/4.5 amps		1	1.500		4.5
TOTAL FOR TENT #1	10	1	4.190	22.35	4.5
Tent #2					
1.) Electric heater 120 V/10.8 amps	1		1.300	10.8	
2.) Radio transceiver 120 V/1000W	1		1.000	8.3	
3.) Light set 120 V.60W ea	1		.360	3.0	
TOTAL FOR TENT #2	3		2.660	22.1	
Tent #3					
1.) X-Ray field 120 V/5 amps	1		.600	5.0	
2.) Film processor 120 V/120W	1		.120	1.0	
3.) Suction field 120 V/140W	1		.140	1.2	
4.) Prophylaxis field 120 V/1500W	1		.150	1.3	
5.) Surgery lamp 120 V/10 amps	1		.200	10.0	
6.) Light set 120 V/60W ea	1		.480	4.0	
TOTAL FOR TENT #3	6		2.690	22.5	
TOTAL REQUIREMENTS	19	1	9.540	66.95	4.5

Figure 1. Power Distribution Plan Example

Generator Selection

6. Choose the proper power source for your mission based on the power analysis total column.

NOTE

If connecting DISE/PDISE equipment to power sources that are paralleled, ensure that connections are made to the switching device between the paralleled generators

Remember that not all power devices will likely be energized at the same time. Therefore, you should determine the maximum power demand during actual operation. These are things to consider when choosing the appropriate DISE/PDISE - power configuration:

- The M40 and M60 distribution systems can provide single phase output, but *cannot* be used in series or be cabled to each other. The M60 system is a stand alone single phase distribution system. You will have to determine the number, type, and location of the M40 and/or M60 amp distribution systems needed.
- When using the M40 distribution system, determine the number and location of M100-amp and/or M200-amp feeder systems, if any. It is more efficient to locate the power consuming equipment as close to the power source as possible, thereby minimizing the need for feeder systems. Refer to WP 0001 for pairing of the distribution systems to the appropriate sized generator.
- The 100-amp feeder system can be used with two or more M40 distribution systems, and the M200-amp feeder system with two or more 100-amp feeder systems.
- The feeder systems can also be used in a stand alone mode to feed power directly to multiple existing pre-wired circuits that require 40 three-phase or 60-amp input power, such as large shelters or systems that have the proper military standard and 120 VAC systems.
- Ensure that the M46 electrical utility assemblies, which provide lighting AC duplex receptacles, are connected only to DISE/PDISE feeder or distribution systems. The M46 does not have built in fuse or circuit breaker protection.

DISE/PDISE Selection

7. Determine the appropriate feeder/distribution system(s) needed which will handle the total amperage required for your mission.

When selecting the DISE/PDISE equipment, you cannot exceed the total amperage rating of the largest feeder/distribution center. The following must be determined when selecting your DISE/PDISE equipment:

- Quantity of M46 Electrical Utility Assemblies needed in each area.
- Quantity of three phase and single phase output connectors used.
- Quantity of Universal Adapters needed for equipment not compatible with DISE/PDISE equipment.

NOTE

Figure 1 determined that one 40-amp system was needed. It is capable of one three-phase and twelve single-phase outputs. Six single-phase output connectors and one three-phase connector on the M40 or M40 A/P will be used to connect all the loads. One M46 Electrical Utility Assembly was determined to be needed to provide illumination and sufficient receptacles to accommodate all the loads. One Universal Adapter will be needed to accommodate the welder. Figure 2 shows the layout of the distribution plan.

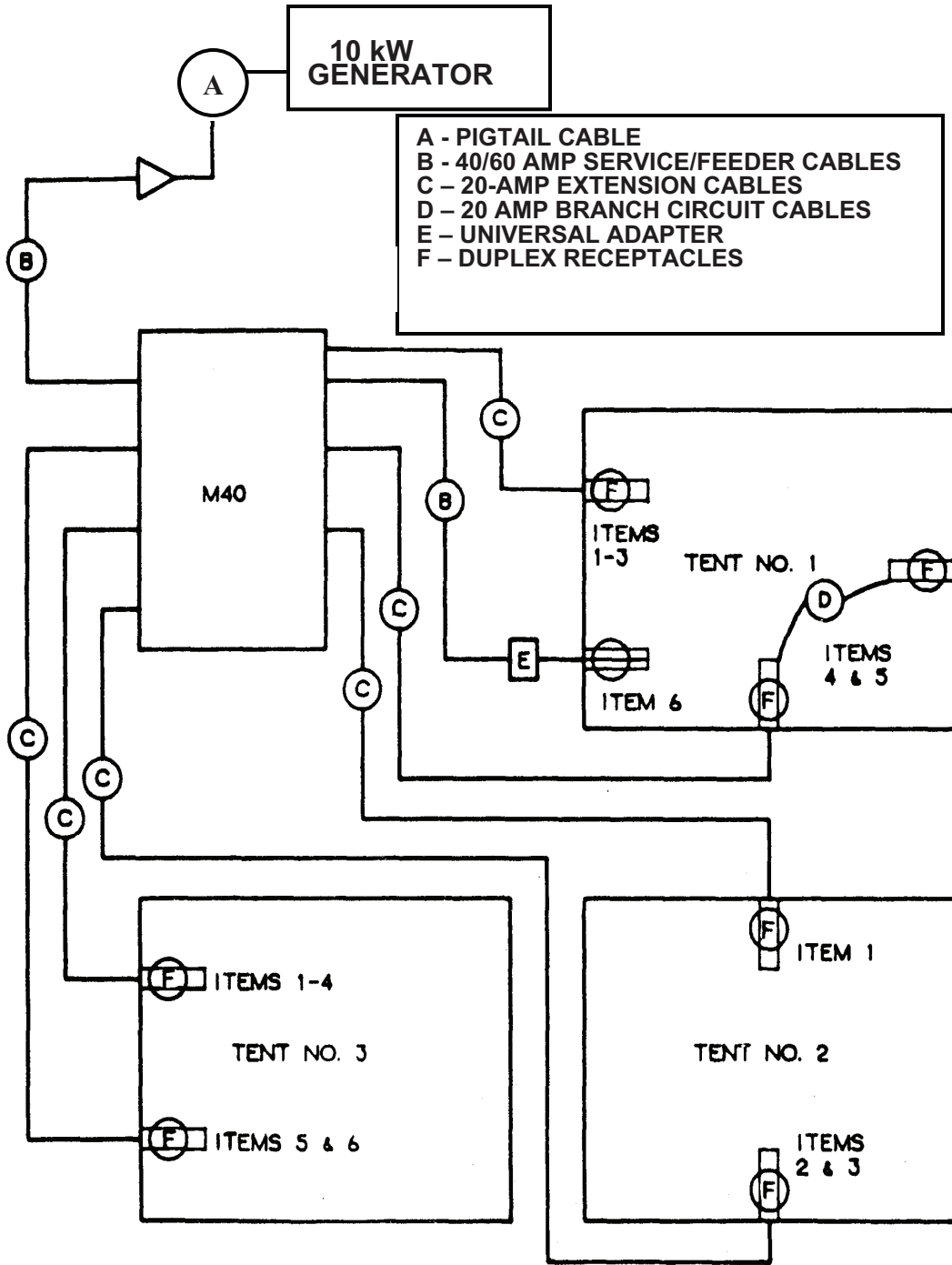

Figure 2. Example of Power Distribution Layout

Phase Balancing

8. Make a phase balancing table similar to one used in Figure 3.

If the DISE/PDISE equipment for your particular field situation uses a three-phase input (M200, 200 A/P, M100, M100 A/P, M40 or M40 A/P system) and single-phase output is required, you will have to allow for phase balancing. Three-phase loads are self-balancing and should be connected first. Refer to Table 2 to determine which output connector should connect to which load for each center.

Each branch circuit cable load must not exceed 2.4 kW or 20 amps (120V x 20 amps – 2400 watts). Each service/feeder cable load must not exceed the kW rating (or amperage rating) of the circuit breaker supporting that load. Table 3 lists the maximum loads for each feeder/distribution center based on output connectors used. Any combination of output connectors can be used as long as the total load does not exceed the capacity of the feeder/distribution center and the load is balanced.

NOTE

The M40 and M40 A/P is capable of 40-amps per phase, 40-amps on L1, 40-amps on L2, and 40-amps on L3.

CAUTION

Distribute the single-phase loads so they are balanced within 10 percent of each other. Phase imbalances greater than 10 percent may cause damage to the generator set.

Area	Item #	Phase A L1	Output Con- nector	Area	Item #	Phase B L2	Output Con- nector	Area	Item #	Phase C L3	Output Con- nector
Tent 1	6	4.5	J2	Tent 3	5-6	4.5	J5	Tent 1	1-3	4.5	J3
Tent 2	2-3	11.3	J7			14.0				17.85	
Subtotal to determine phase with least amps		15.8		Subtotal to determine phase with least amps		18.5		Subtotal to determine phase with least amps		22.35	
Tent 2	1	10.8	J13	Tent 3	1-4	8.5	J11	Tent 1	4-5	4.5	J9
TOTAL		26.6		TOTAL		27.0		TOTAL		26.85	

Figure 3. Example of Load Assignments for Three/Single Phase Output Connectors of the M40 or M40 A/P.

9. Connect all three phase loads first.
10. Connect the largest single phase loads.
11. Connect the next largest single-phase load to the phase with the least amperage.
12. Continue connecting the single-phase loads, largest to smallest until all loads are connected.

Table 2. Connector to Phase Links – DISE/PDISE

Center/Connector	A L1	B L2	C L3	N
200-amp feeder center				
J-1 200-amp input 3-ph.....	X	X	X	X
J-4 100-amp output 3-ph.....	X	X	X	X
J-5 100-amp output 3-ph.....	X	X	X	X
* J-6 20-amp output GF.....		X		X
J-7 60-amp output 3-ph.....	X	X	X	X
J-8 60-amp output 3-ph.....	X	X	X	X
J-9 60-amp output 3-ph.....	X	X	X	X
J-10 60-amp output 3-ph.....	X	X	X	X
J-11 100-amp output 3-ph.....	X	X	X	X
100-amp feeder center				
J-1 100-amp input.....	X	X	X	X
J-2 100-amp output.....	X	X	X	X
J-3 60-amp output.....	X	X	X	X
J-4 40-amp output.....	X	X	X	X
J-5 40-amp output.....	X	X	X	X
J-6 60-amp output.....	X	X	X	X
* J-7 20-amp output GF.....			X	X
* J-8 20-amp output GF.....	X			X
40-amp distribution center				
J-1 40-amp input.....	X	X	X	X
J-2 40-amp output.....	X	X	X	X
* J-3 20-amp output GF.....			X	X
J-4 20-amp output.....			X	X
* J-5 20-amp output GF.....		X		X
J-6 20-amp output.....		X		X
* J-7 20-amp output GF.....	X			X
J-8 20-amp output.....	X			X
* J-9 20-amp output GF.....			X	X
J-10 20-amp output.....			X	X
* J-11 20-amp output GF.....		X		X
J-12 20-amp output.....		X		X
* J-13 20-amp output GF.....	X			X
* J-14 20-amp output GF.....	X			X
60-amp distribution center				
J-1 60-amp input.....	X			X
J-2 60-amp output.....	X			X
* J-3 20-amp output GF.....	X			X
J-4 20-amp output.....	X			X
* J-5 20-amp output GF.....	X			X
J-6 20-amp output.....	X			X
* J-7 20-amp output GF.....	X			X
J-8 20-amp output.....	X			X

* Both DISE and PDISE Systems contain 20 amp circuits. Only DISE systems utilize ground fault (GF) breakers.

Table 3. Feeder/Distribution Center Output Connector Loads

Connector Type (Max Connector Load)	Balanced Connector kW Load	No of. Connectors	Total kW Load
a. M200 and M200 A/P Feeder Centers (72 kW total output capacity)			
100-amp, 8-pin, 3-phase (36 kW)	24	3	72*
60-amp, 5-pin, 3-phase (21.6 kW)	18	4	72*
20-amp, 3-pin single-phase (2.4 kW)	2.4	1	2.4
b. M100 and M100 A/P Feeder Centers (36 kW total output capacity)			
100-amp, 8-pin, 3-phase (36 kW)	36	1	36*
60-amp, 5-pin, e-phase (21.6 kW)	18	1	36*
40-amp, 5-pin, 3-phase (14.4 kW)	14.4	2	28.8
20-amp, 3-pin, single-phase (2.4 kW)	2.4	2	4.8
c. M40 and M40 A/P Distribution Centers (14.4 kW total output capacity)			
40-amp, 5-pin, 3-phase (14.4 kW)	14.4	1	14.4*
20-amp, 3-pin, single-phase (2.4 kW)	1.2	12	14.4*
d. M60 and M60 A/P Distribution Centers (7.2 kW total output capacity)			
60-amp, 4-pin, single-phase (7.2 kW)	7.2	1	7.2*
20-amp, 3-pin, single-phase (2.4 kW)	1.2	6	7.2*

*Requires feeder/distribution center's total output capacity.

Cable Selection/Routing/Connection

13. Choose the appropriate cable(s) based on the distance(s) between the location selected for the generator set, the distribution center, and the tents.

NOTE

Remember, the longer the cable, the greater the voltage loss at the user's end. For maximum efficiency, keep the total cable lengths between the generator set and the user equipment under 300 feet (91.44 meters). If the user equipment is too sensitive to voltage loss, you may have to use shorter cables.

WARNING

High voltage is present in this system. DISE and PDISE supports equipment using 120/208 VAC. Do not submerge cable connectors in water. Death or severe injury may result.

CAUTION

Take caution when burying cables which cross roadways. DISE and PDISE cables may be damaged by tactical vehicles.

14. Route the system cables to avoid vehicle roadways and troop walkways.
 - a. If a cable must cross a roadway, bury the cable (refer to FM 20-31) to protect it from any damage. Do not lay cable connectors in depressions where water can collect.
 - b. Lubricate cables to aid in mating female and male connectors.
15. Connect cables by working outward from user's equipment to the feeder/distribution center.
 - a. To prevent disconnections and any unsafe conditions, secure branch circuit cables to fixed objects (i.e tents, grounding rods) using given straps.
 - b. Connect required number of duplex receptacle boxes to the branch circuit cable(s).
 - c. Connect any extension cables needed between the branch circuit cable(s) and the appropriate distribution/feeder center output connector.
 - d. Connect a service/feeder cable of the desired length to the distribution center output connector. Connect the other end to the power consuming device.

NOTE

If there is a device that does not contain a military standard connector, use the universal adapter described later on in this WP.

- e. Repeat Steps 15a through d for each additional device.
- f. Connect the pigtail cable to a service/feeder cable of the desired length. (Refer to Table 2, WP 0001)
- g. Connect the service/feeder cable to in the input connector of the distribution/feeder center.

Generator Connection

WARNING

- High voltage is present in this system. DISE and PDISE support equipment using 120/208 VAC. Do not connect cables to the generator set with the power on. Death or severe injury may result.
- Ground the generator set. Death or severe injury may result if you do not properly ground the generator set.

Connect the ground leads (green) of the pigtail cable to the ground terminal of the generator set. Death or severe injury may result if you do not properly connect the ground leads to the generator set.
- The DISE feeder/distribution centers use ground fault circuit breakers. The neutral and ground of some generator sets must be electrically connected with 6-gage wire for the ground fault circuit breakers to function properly. Failure to electrically connect the ground and neutral lugs may result in death or severe injury.

-
16. Physically check that the generator set is properly grounded. Refer to the appropriate generator set manual for proper grounding procedures.

WARNING

High voltage is present in this system. DISE/PDISE support equipment using 120/208 VAC. Do not rely on the color of the wire insulation for phase color-coding. The insulation on the wires inside the cable jacket may vary, depending on the supplier. Wires will be color-coded to designate the phases. Perform a continuity test to verify correct phase designation in accordance with identified color.

17. Connect the pigtail cable to the generator set as follows:

- Black lead (phase A) to L1
- Red lead (phase B) to L2
- Blue lead (phase C) to L3
- White lead (neutral) to L0

NOTE

For eight-lead cables, twist the four green ground wires together and connect to ground.

- Green (or bare) leads to ground

18. If the use of the universal adapter is needed, continue to those procedures contained in this WP. If no other connections are necessary, continue on to Operating Procedures in this WP.

Universal Adapter Hookup Procedures

The universal adapter is designed to connect electrical equipment without military standard connectors to the electrical power distribution equipment. The universal adapter (Figure 4) consists of a box with a 5-pin, 3-phase 40/60 amp input connector and five terminals. The box includes an insulated wrench for tightening/loosening the terminals.

WARNING

- High voltage is present in this system. DISE and PDISE supports equipment using 120/208 VAC. Do not connect equipment with the power on. Death or serious injury may result.
- Do not rely on the color of the wire insulation for phase color-coding.
- The insulation on the wires inside the cable jacket may vary, depending on the supplier. Wires will be color-coded to designate the phases. Perform a continuity test to verify correct phase designation in accordance with identified color.

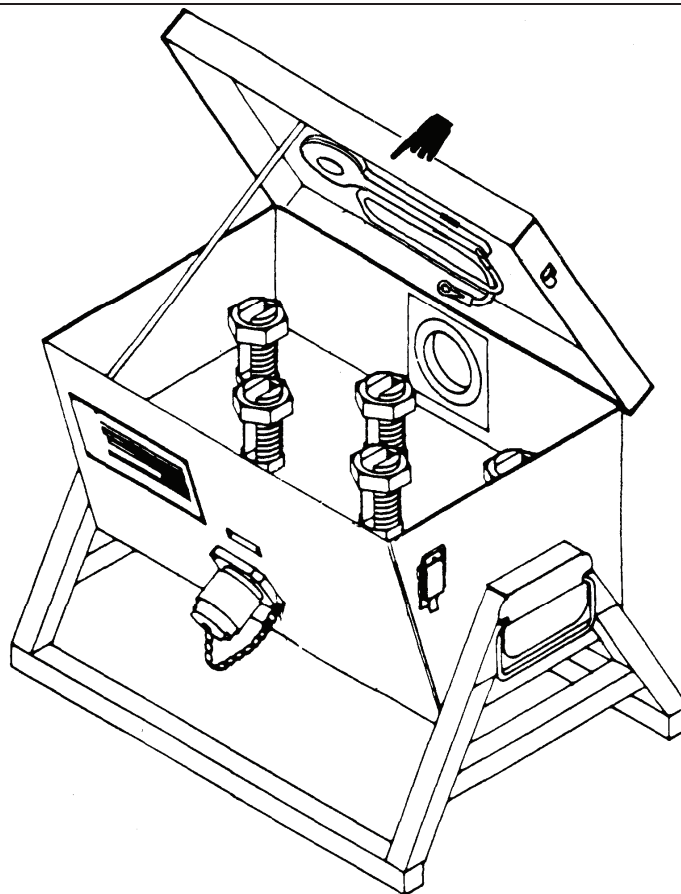

Figure 4. Universal Adapter

CAUTION

- If equipment using 3-phase motors is not operating properly, your equipment may be in reverse phase and must be shut down immediately or damage to equipment may occur. To obtain correct phase, change any two of the 3-phase leads.

- When tightening split lug terminals, use provided insulated wrench to prevent over tightening. Failure to use the provided wrench may result in equipment damage.

1. Connect the user's equipment to the output studs of the universal adapter as follows:

- L1 to phase A (black)
- L2 to phase B (red)
- L3 to phase C (blue)
- L0 to neutral (white)
- G to ground (green or bare wires)

2. Connect a 40/60 amp, 5-wire cable to the input connector of the universal adapter.

3. Connect the 40/60-amp, 5-wire cable to the proper distribution center output connector.

OPERATING PROCEDURES

Starting Procedures

WARNING

- High voltage is present in this system. DISE/PDISE support equipment using 120/208 VAC. Secure connector cover on unused feeder/distribution center output connectors to avoid electrical shock. Failure to do so may result in death or death or serious injury to personnel.
- Before turning on electrical power, alert all users. Failure to do so may result in death or severe injury to personnel.

CAUTION

- Never block circuit breaker switches in the ON position. Excessive current will damage DISE/PDISE equipment. Failure to observe caution may damage equipment.
- Do not block the feeder/distribution center lids in the open position. Rainwater may accumulate inside feeder/distribution center and damage components. Failure to observe this caution may damage equipment.

NOTE

Refer to proper technical manuals and FM 20-31 for operating procedures relating to the particular generator set used with your DISE/PDISE systems.

1. If needed, ensure proper Operator PMCS is performed prior to applying power. (See WP 0008)
2. Set each DISE and PDISE feeder/distribution center main circuit breaker to **OFF**.
3. Start the generator set.
4. Start with the feeder/distribution center electrically closest to the generator and set the feeder/distribution center main circuit breaker **ON**.
5. Set the circuit breaker for the branch circuits being used to **ON**.
6. Check the current output at the generator for each phase (3-phase systems only).
 - If the current draw for any one phase is 10 percent greater than any other, open all DISE or PDISE circuit breakers and shut down the generator set. Reconnect the user's loads to the various branch circuit output connectors until all three phases are evenly balanced.
 - If all systems are operational, ensure to continue proper PMCS procedures contained in WP 0013.

Testing/Resetting Ground Fault Circuit Breakers (GFCI)

1. Apply power to center being tested.
2. Push the red **“TEST”** button.
 - The GFCI should trip. A circuit breaker in the tripped position (midway between On and OFF positions) indicates the circuit breaker has been subjected to an overload condition.

NOTE

A circuit breaker starting in the **OFF** position indicates the circuit breaker has not been operated.

3. Wait 2 minutes before resetting circuit breaker.
4. Reset the circuit breaker by moving the switch to the **OFF** position and then to the **ON** position.
 - If the circuit breaker trips again after resetting, the overload or fault must be cleared before safe operation can be resumed. Record actions on DA Form 2404 and notify next level maintenance.
 - If no fault or overload condition is detected and system is working to full capacity, record the appropriate information on the “Ground Fault Test Record”. (See WP 0002)

Shut Down

1. Turn off the individual branch circuit breakers on the feeder/distribution centers.
2. Start with the feeder/distribution center electrically closest to the user’s equipment and turn off the main circuit breaker of each feeder/distribution center.
3. Refer to proper generator technical manual to shut down generator.

PREPARATION FOR MOVEMENT**WARNING**

High voltage is present in this system. DISE/PDISE support equipment using 120/208 VAC. Do not attempt to disconnect the equipment with the electrical power on. Death or severe injury may result.

CAUTION

Dirt and contamination may plug connector sockets. Secure cap on connectors when disassembling the equipment. Failure to observe this may result in damage to equipment.

1. Shut down the DISE/PDISE system as per this WP.
2. Starting at the user's end, disconnect the user's equipment.
3. Disconnect the lights and branch circuit cables.
4. Disconnect the extension cables.
5. Disconnect service/feeder cables.
6. Disconnect the pigtail cables.
7. Install the connector caps and perform proper PMCS. (See WP 0008)
8. Coil the service/feeder cables up and attach cable carrying straps.
9. Store the pigtail, extension, and branch circuit cables along with the lights, plugs, and any other loose items in the transit storage container.
10. Secure latches on the feeder/distribution center and install connector caps.

END OF WORK PACKAGE

**OPERATOR AND FIELD MAINTENANCE MANUAL
DISE AND PDISE SYSTEMS
OPERATION UNDER UNUSUAL CONDITIONS**

INITIAL SETUP:**Tools and Special Tools**

None

Personnel Required

One

Materials and Parts

Dry Rag (Item 8, WP 0037)

References

FM 3-4

FM 3-5

Equipment Conditions

Gen Set Power ON

UNUSUAL ENVIRONMENT/WEATHER**WARNING**

- High Voltage is present in this system. DISE/PDISE support equipment using 120/208 VAC. Ground the generator set. Death or severe injury may result if you do not properly ground the generator set.
- The DISE feeder/distribution centers use ground fault circuit breakers. The neutral and ground of some generator sets must be electrically connected with 6-gage wire for the ground fault circuit breakers to function properly. Failure to electrically connect the ground and neutral lugs may result in death or severe injury.
- Do not rely on the color of the wire insulation for phase color-coding. The insulation on the wires inside the cable jacket may vary, depending on the supplier. Wires will be color coded to designate the phases. Perform a continuity test to verify correct phase designation in accordance with the identified color.
- Connect the pigtail ground leads to the generator set. Death or severe injury may result if you do not properly connect the ground leads of the pigtail cables to the generator set.
- Do not submerge feeder/distribution centers or cable connector in water. Death or severe injury may result.

Operation in Extreme Cold (Below 0°F [-18°C]).**WARNING**

Do not touch cold metal parts with bare hands.
Frostbite can cause permanent injury.

1. The DISE and PDISE equipment is designed for operation down to -25°F (- 32°C).
2. Cap unused connectors to protect against moisture.

3. Close and latch the feeder/distribution center lids to protect against moisture.
4. When coiling cables, form large loops due to cables being difficult to coil in subzero temperatures.

Operation in Extreme Heat (Above 120° F [49°C]).

DISE and PDISE should not be exposed to direct sunlight. DISE and PDISE boxes should be placed in the shade or shade should be created, especially when supplying power to equipment needing uninterrupted power. To reduce the effects of heat absorption, DISE and PDISE should be placed on the shady side of a building or structure, under canvas, camouflaged, or in a tent. The DISE and PDISE boxes should be well ventilated.

Operation in Rainy or Humid Conditions

WARNING

High voltage is present in this system. DISE/PDISE support equipment using 120/208 VAC. Do not allow DISE or PDISE feeder/distribution center or cable connectors to be submerged in water. Death or severe injury may result to personnel.

1. Take special precautions to keep DISE/PDISE feeder/distribution centers dry. If possible, provide a shelter for the centers. If a sheltered area is not available, cover the centers with canvas or any means necessary.
2. Do not allow feeder/distribution centers or cable connectors to be submerged in water.
3. Cap unused connectors to protect against moisture.
4. Close and latch the feeder/distribution centers lids to protect against moisture.
5. Check that the generator set is properly grounded and that the pigtail cable ground wires are properly connected to the generator set.

Operation in Saltwater Area

WARNING

High voltage is present in this system. DISE/PDISE supports equipment using 120/208 VAC. Do not allow DISE or PDISE feeder/distribution center or cable connectors to be submerged in water. Death or severe injury may result to personnel.

1. Take special precautions to keep DISE and PDISE feeder/distribution centers dry. If possible, provide a shelter for the centers. If a sheltered area is not available, cover the centers with canvas.
2. Do not allow feeder/distribution centers or cable connectors to be submerged in water.
3. Cap unused connectors to protect against moisture.
4. Close and latch the feeder/distribution centers lids to protect against moisture.

-
5. If DISE or PDISE equipment is operated in a saltwater area for an extended period of time, perform the following at weekly intervals:
 - a. Shut down the DISE or PDISE network and generator sets. (WP 0003)
 - b. Disconnect the DISE or PDISE feeder/distribution center from the cables.
 - c. Clean the face of the circuit breakers with a dry rag (WP 0037).
 - d. Wipe internal and external surfaces of the feeder/distribution center with a damp, clean rag.
 - e. Allow centers to dry thoroughly.
 - f. Reconnect the centers to the network cables.
 - g. Refer to WP 0003 and restart the system.

Operation in Dusty or Sandy Areas

1. Shield the DISE and PDISE feeder/distribution centers from blowing dust and sand. Take advantage of natural barriers which offer protection from sand and dust.
2. Cap unused connectors to protect against sand and dirt.
3. Close and latch the feeder/distribution center lids to protect against sand and dust.

Nuclear, Biological, and Chemical (NBC) Decontamination Procedures

For detailed contamination procedures, refer to FM 3-5, Nuclear, Biological, and Chemical Decontamination, and FM 3-4, Nuclear, Biological, and Chemical Protection.

Chapter 3

OPERATOR TROUBLESHOOTING PROCEDURES

**OPERATOR TROUBLESHOOTING PROCEDURES
DISE AND PDISE SYSTEMS
TROUBLESHOOTING INDEX**

INITIAL SETUP:

Tools and Special Tools

None

Personnel Required

One

Materials and Parts

None

References

WP 0006

Equipment Conditions

INTRODUCTION

This section contains troubleshooting information and tests for the operator to locate and correct malfunctions for DISE/PDISE models. These malfunctions may be observed by the operator during PMCS and during normal operations of the system. The malfunction/symptom index lists malfunctions which are authorized by the MAC followed by a list of probable causes and corrective action.

Troubleshooting consists of isolating the system in which the malfunction occurs and locating the defective component, using testing devices and tools identified in the Maintenance Allocation Chart.

The index lists the common malfunctions which you may find during the operating or maintenance of DISE/PDISE or its components. You should perform the tests/inspections and corrective actions in the order listed. This manual cannot list all malfunctions that may occur, nor all tests or inspections and corrective actions. If a malfunction is not listed or is not corrected by listed corrective actions, notify the next level of maintenance.

Symptom/Malfunction Index	WP0006 Item #
Feeder/Distribution Centers User's Equipment Will Not Operate.....	1
Circuit Breaker Supporting User's Load Repeatedly Trips.....	2
User's Equipment Operates Erratically or too Slowly.....	3

END OF WORK PACKAGE

**OPERATOR TROUBLESHOOTING PROCEDURES
DISE AND PDISE SYSTEMS
TROUBLESHOOTING PROCEDURES**

INITIAL SETUP:**Tools and Special Tools**

None

Personnel Required

One

Materials and Parts

None

References

WP 0001

Equipment Conditions

Powered up

MALFUNCTION**TEST OR INSPECTION****CORRECTIVE ACTION**

WARNING

High voltage is present in this system. DISE/PDISE support equipment using 120/208 VAC. Be careful not to contact high-voltage connections when troubleshooting this equipment. Death or serious injury may result.

1. USER'S EQUIPMENT WILL NOT OPERATE.

Step 1. Check phase indicator light on nearest center supporting user's load.

(a). If phase indicator lights are on, go to **Step 2**.

(b). If phase indicator lights are off, go to **Step 3**.

Step 2. Check circuit breaker on nearest center supporting user's load for trip indication.

CAUTION

Do not block circuit breakers in ON position. Excessive current will damage DISE and PDISE equipment. Failure to observe caution may result in damage to equipment.

(a). If breaker is tripped, reset it. If circuit breaker continues to trip, continue to **Malfunction #2**.

(b). If circuit breaker is not tripped, notify higher level of maintenance.

Step 3. Check phase indicator lights on other centers (if any) in network.

(a). If phase indicator lights on other centers are not tripped, notify next higher level of maintenance.

-
- (b). If phase indicator lights on other centers are on, but phase indicator lights on center supporting user's loads are off, notify unit maintenance.
- (c). If phase indicator lights on all network centers are off, refer to proper TM and check generator for proper output.
-

MALFUNCTION**TEST OR INSPECTION****CORRECTIVE ACTION****2. CIRCUIT BREAKER SUPPORTING USER'S LOAD REPEATEDLY TRIPS.****CAUTION**

Do not block circuit breakers in ON position. Excessive current will damage DISE and PDISE equipment. Failure to observe caution may result in damage to equipment.

Step 1. Recalculate load requirements for circuit that is tripping. (See WP 0003)

- (a). If total load requirements exceed circuit breaker rating, redistribute load by running an additional extension and branch circuit to user's equipment.
- (b). If user's total load requirements are less than circuit breaker rating and circuit breaker still trips, notify next higher level of maintenance.

3. USER'S EQUIPMENT OPERATES ERRATICALLY OR TOO SLOWLY.

Step 1. Check generator for proper output. Refer to proper TM and adjust generator.

Step 2. Check cables and connectors for proper connections. Properly connect cables and connectors.

Step 3. Calculate voltage loss due to cable length (Table 3, WP 0001). Use shorter cable as necessary to reduce voltage loss.

Step 4. If the setup and generator output are correct and malfunction still exists, notify next level maintenance.

END OF WORK PACKAGE

Chapter 4

OPERATOR MAINTENANCE PROCEDURES

**OPERATOR MAINTENANCE INSTRUCTIONS
DISE AND PDISE FEEDER/DISTRIBUTION SYSTEMS
PMCS INTRODUCTION**

INITIAL SETUP:

Tools

None

Personnel Required

One

References

DA Form 2404
TM 43-0139
DA PAM 750-1
TM 38-230-1
WP 0008
WP 0031
WP 0035

Equipment Conditions

None

GENERAL

Your PMCS table (WP 0008) has been provided so you can keep your equipment in good operating condition and ready for its primary mission. The PMCS contains those checks and services authorized to the Operator Level by the Maintenance Allocation Chart (MAC) (WP 0035)

MAINTENANCE INSTRUCTIONS

Always observe **WARNINGS** and **CAUTIONS** appearing in your PMCS table to prevent serious injury to yourself and others or to prevent your equipment from being damaged. These precautions have been placed before the applicable procedures. Some other important reminders include:

- Replace or repair defective components you discover during PMCS.
- To facilitate assembly and installation, apply identifying tags to mating points of electrical lines when they are disconnected. WP 0031 shows complete wiring diagrams for appropriate DISE and PDISE equipment.
- Remove only those parts requiring repair or replacement. Tag similar parts to ensure correct assembly. Do not disassemble a component any further than necessary to accomplish needed repairs.
- Refer to wiring diagrams and identifying tags when assembling DISE and PDISE equipment. Wires are marked to aid you in assembly of the feeder/distribution centers.

EXPLANATION OF TABLE ENTRIES

- (1) Item number column. Numbers in this column are for reference. When completing DA Form 2404, Equipment Inspection and Maintenance Worksheet, include the item number for the check/service indicating a fault: Item numbers also appear in the order that you must do checks and services for the intervals listed.
 - (2) Interval column. This column tells you when you must do the procedure in the procedure column.
-

- (3) Check/Service column. This column provides the location and the item to be checked or serviced.
- (4) Procedure column. This column gives the procedure you must do to check or service the item listed in the Check/Service column to know if the equipment is ready or available for its intended mission or for operation. You must do the procedure at the time state in the interval column.
- (5) Not fully mission capable if: column. Information in this column tells you what faults will keep your equipment from being capable of performing its primary mission. If you make check and service procedures that show faults listed in this column, do not operate the equipment. Follow standard operating procedures for maintaining the equipment or reporting equipment failure.
- (6) Other table entries. Information other than warnings, cautions, and notes appear in the PMCS table. Be sure to observe all special information appearing in your table.

PMCS INSTRUCTIONS.

NOTE

- All DISE and PDISE subsystems are similar and contain similar components. Subsystems are combined in the PMCS chart and component checks for similar items are shown under a signal heading.
- If the equipment must be kept in continuous operation, do only the procedures that can be done without disturbing operation. Make complete checks and services when equipment is shut down.
- If you discover a maintenance problem while performing PMCS, troubleshoot it in the prescribed Work Package- Report any malfunctions or failures on the proper DA Form 2404, Equipment Inspection and Maintenance Work Sheet, or refer to DA Pam 750-1.
- Corrosion Prevention and Control (CPC) of Army Materiel is a continuing concern. It is important that any corrosion problems with DISE and PDISE be reported so that the problem can be corrected and improvements can be made to prevent the problem in future items. While corrosion is typically associated with rusting of metals, it can also include deterioration of other materials, such as rubber and plastic. Unusual cracking, softening, swelling, or breaking to these materials may be a corrosion problem is identified, it can be reported using Standard Form 368, Product Quality Deficiency Report. The form should be submitted to the address Specified in DA Pam 750-1. Corrosion can be prevented and controlled by following PMCS procedures.

END OF WORK PACKAGE

**OPERATOR MAINTENANCE INSTRUCTIONS
DISE AND PDISE SYSTEMS
PREVENTIVE MAINTENANCE CHECKS AND SERVICES (PMCS)**

INITIAL SETUP:

Tools and Special Tools

None

Personnel Required

One

Materials and Parts

None

References

WP 0001
WP 0003
WP 0007
WP 0036

Equipment Conditions

System is Shut Down

Table 1. Operator Preventive Maintenance Checks and Services.

Item	Interval	Location Item to Check/Service	Procedure	Not fully Mission Capable if:
1	Before	Electrical Feeder System M200, 200(AP) M100, 100 (AP)	<p align="center">WARNING</p> <p>High voltage is present in this equipment. DISE/PDISE supports equipment using 120/208 VAC. Do not perform PMCS with the power on. Death or serious injury may result.</p> <p>a. Check that unused connectors are capped and center lid is closed.</p>	
2	Before	Circuit breaker	a. Check for damaged circuit breakers.	Circuit breakers are damaged so as to affect the function or safety. Notify next level maintenance.
3	Before	Connectors on feeder system	a. Check for damaged connectors. Ensure that all pins and connector lugs are serviceable.	Connectors are damaged, burnt, broken or missing. Notify next level maintenance.

Table 1. Operator Preventive Maintenance Checks and Services. (Con't)

Item	Interval	Location Item to Check/Service		
4	Before	Pigtail cable and end connectors.	<p style="text-align: center;">WARNING</p> <p>High voltage is present in this system. DISE and PDISE supports equipment using 120/208 VAC. Do not rely on the color-coding. The insulation on the wires inside the cable jacket may vary, depending on supplier. Wires will be color coded to designate the phases. If the wire color coding cannot be determined, notify next higher level of maintenance to perform continuity test. Perform a continuity test to verify correct phase designation in accordance with identified color.</p> <p>a. Check that all ground wires are securely attached to ground terminals. Check connectors, ensure that all pins and connector lugs are serviceable.</p>	Pigtail cable has exposed wires or frayed/missing ground wires. Notify next level maintenance.
5	Before	Service feeder cable assy.	a. Check for exposed wiring. Split, cut or damaged insulation.	Wiring is exposed, insulation cut, split.
6	Before	Phase indicator light	a. Check for damaged light/light socket	Notify next level maintenance.
7	Before	Electrical distribution system M40, M40 (AP) M60, M60 (AP)	a. Check that unused connectors are capped and center lid is closed.	

Table 1. Operator Preventive Maintenance Checks and Services. (Con't)

Item	Interval	Location Item to Check/Service	Procedure	Not fully Mission Capable if:
8	Before	Connectors	a. Check all connectors for broken pins, damaged lugs and that all cable connectors are securely fastened. Notify field maintenance.	Connectors are damaged. Notify next level maintenance.
9	Before	Distribution center circuit breakers	<p>a. Check circuit breakers for damage and proper operation. Notify field maintenance.</p> <p style="text-align: center;">WARNING</p> <p>High voltage is present in this system. DISE and PDISE supports equipment using 120/208 VAC. Do not rely on the color-coding. The insulation on the wires inside the cable jacket may vary, depending on supplier. Wires will be color coded to designate the phases. If the wire color coding cannot be determined, notify next higher level of maintenance to perform continuity test. Perform a continuity test to verify correct phase designation in accordance with identified color.</p>	Circuit breakers are damaged so as to affect the function or safety. Notify next level maintenance.
10	Before	Pig tail/ ground wires	a. Check that all ground wires are securely attached to ground terminals.	Pigtail cable ground wires are frayed or missing. Notify next level maintenance.

Table 1. Operator Preventive Maintenance Checks and Services. (Con't)

Item	Interval	Location Item to Check/Service	Procedure	Not fully Mission Capable if:
11	Before	Extension Cable Assy.	a. Check for damaged cable connectors.	Any faults found, notify next level maintenance.
12	Before	Electrical Utility Kit M46	a. Perform inventory of all items according to Component of End Item List. (WP 0036)	Missing items.
13	Before	Receptacle groups duplex-boxes	a. Check for damaged receptacle groups and connectors.	
14	Before	Cable assembly, Branch circuit (24ft)	a. Check for damaged cable connectors and split, cut insulation. Check for frayed or exposed wires. Ensure truck assembly is still attached.	Cable connectors are damaged or bare wires are exposed. Notify next level maintenance.
15	Before	Extension Cable Assembly (15 or 25ft)	a. Check for damaged cable connectors and split, cut insulation. Check for frayed or exposed wires.	Cable connectors are damaged or bare wires are exposed. Notify next level maintenance.
16	Before	Utility Light Assembly/Fluorescent and/or Incandescent Light	a. Check for frayed or exposed wires. Cable is damaged. Broken bulbs.	Bulbs are broken.
17	Before	Universal Adapter	a. Check for damaged enclosure assembly.	Enclosure is damaged so that internal wiring is exposed or it will not close.

Table 1. Operator Preventive Maintenance Checks and Services. (Con't)

Item	Interval	Location Item to Check/Service	Procedure	Not fully Mission Capable if:
18	During	Electrical Feeder System M200, M100	a. Press ground fault test switch and verify that circuit breaker trips.	Ground fault circuit breaker fails to trip.
19	After	Electrical Feeder System M200, M200 (AP) M100, M100 (AP)	a. Clean face of circuit breaker with a dry rag (Item 8, WP 0038). Wipe internal and external surfaces with a damp, clean rag.	
20	After	Cable Assemblies	a. Clean face of circuit breaker with a dry rag. Wipe internal and external surfaces with a damp, clean rag.	
21	After	Electrical Distribution System M40, M40 (AP) M60, M60 (AP)	a. Clean with a rag soak in a mild detergent solution (item 2, WP 0038). Dry surface with a damp, clean rag.	
22	After	Transit and storage container	a. Check for damaged transit and storage container such as Broken latches	
23	After	Cable assembly, Branch circuit (24ft)	a. Clean with a rag, soaked in a mild detergent solution. Dry surface with a damp, clean rag.	
24	After	Universal Adapter	a. Wipe internal and external surfaces with a damp clean rag.	

END OF WORK PACKAGE

Chapter 5

FIELD LEVEL TROUBLESHOOTING

**FIELD LEVEL TROUBLESHOOTING PROCEDURES
DISE AND PDISE EQUIPMENT
TROUBLESHOOTING INTRODUCTION**

INTRODUCTION

This section contains troubleshooting information and test for maintenance personnel to locate and correct malfunctions for DISE/PDISE models. These malfunctions may be observed during PMCS and/or during normal operations of the system or maintenance. The troubleshooting table below lists malfunctions which are authorized by the Maintenance Allocation Chart (MAC) followed by a list of probable causes and corrective action.

Troubleshooting consists of isolating the system in which a malfunction occurs and the process of locating the defective component using testing devices and tools identified in the Maintenance Allocation Chart.

The table below lists the common malfunctions which you may find during the operation or maintenance of DISE/PDISE or its components. You should perform the tests/ inspections and corrective actions in the order listed. The manual cannot list all malfunctions that may occur, nor all tests or inspections and corrective actions. If a malfunction is not listed or is not corrected by listed corrective actions, notify next higher level of maintenance. For wiring diagrams (See WP 0031), be sure as to identify which system/model of DISE/PDISE you are troubleshooting.

COMPONENT REFERENCE DESIGNATORS

* Electrical **phases** are designated with one of two designations as follows:

1. Phase A or L1
2. Phase B or L2
3. Phase C or L3
4. Neutral (N) or L0

* DISE and PDISE feeder/distribution center **wires** are designated with the following examples:

1. **Example 1-** J2A4L1 is broken down as follows:
 - a. J2A = wire originates from connector J2, pin A.
 - b. 4-wire = #4 gauge.
 - c. L1 = wire connects to phase bus L1 (phase A).
2. **Example 2-** J8B12NEUT.
 - a. J8B = wire originates from connector J8, pin B.
 - b. 12 = wire is #12 gauge.
 - c. NEUT = wire connects to neutral phase bus (L0).
3. **Example 3-** J14A12CB14.
 - a. J14A = wire originates from connector J14, pin A.
 - b. 1 = wire is #12 gauge.
 - c. CB14 = wire connects to circuit breaker #14.

Table 1. Malfunction/Symptom Index

MALFUNCTION/SYMPTOM INDEX	WP 0010 Item
User's Equipment will not Operate and	
All Phase indicator Lights are On.....	1
All Phase indicator Lights are Off.....	2
3-Phase Indicator Lights are On.....	3
3-Phase indicator Lights are Off	4
Circuit Breakers Supporting User's Load Repeatedly Trips.....	5

END OF WORK PACKAGE

**FIELD LEVEL TROUBLESHOOTING PROCEDURES
DISE AND PDISE SYSTEMS
TROUBLESHOOTING PROCEDURES**

INITIAL SETUP:**Tools**

General Mechanic's Automotive Tool Kit
(Item 1, WP 0035)

References

WP 0003
WP 0018
WP 0020
WP 0024
WP 0027
WP 0035

Materials/Parts

None

Equipment Conditions

Power is ON

MALFUNCTION**TEST OR INSPECTION****CORRECTIVE ACTION**

-
1. **USER'S SINGLE-PHASE (120 V) EQUIPMENT WILL NOT OPERATE AND ALL PHASE INDICATOR LIGHTS ARE ON.**

WARNING

High voltage is present in this system. DISE/PDISE support equipment using 120/208 VAC. Disconnect power before performing continuity checks. Be careful not to contact high-voltage connections when troubleshooting this equipment. Death or serious injury may result.

- Step 1.** Use a multimeter and check for proper voltage at duplex receptacle supporting user's equipment. (See WP 0024)
 - (a) If proper voltage is present, perform user equipment PMCS.
 - (b) If proper voltage is not present, go to **Step 2**.
 - Step 2.** Check output voltage at power source supporting user's equipment.
 - (a) If proper voltage is present, sequentially check for proper output voltage at each cable between last center and user's equipment. Replace cable as necessary.
 - (b) If proper voltage is not present, go to **Step 3**.
 - Step 3.** Check for proper output voltage at circuit breaker connected to output connector supporting user's load.
 - (a) If proper voltage is present, replace output connector (See WP 0020).
-

- (b) If proper voltage is not present, perform GFCI Breaker test. (See WP 0003)
- (c) If proper voltage is still not present, replace circuit breaker (WP 0018)

MALFUNCTION
TEST OR INSPECTION**CORRECTIVE ACTION**

2. USER'S SINGLE-PHASE (120 VAC) EQUIPMENT WILL NOT OPERATE AND PHASE INDICATOR LIGHTS ARE OFF.

Step 1. Use a multimeter and check for proper voltage at output connector of center that is nearest to user's load and has all phase indicator lights on.

- (a) If proper voltage is present, replace cable between center with phase indicator lights on and center with phase indicator lights off.
- (b) If proper voltage is not present, go to **Step 2**.

Step 2. Check output voltage at circuit breaker connected to output connector supporting user's load.

- (a) If proper voltage is present, replace output connector (WP 0020).
- (b) If proper voltage is not present, perform GFCI breaker test. (See WP 0003)
- (c) If proper voltage is still not present, replace circuit breaker (WP 0018).

3. USER'S 3-PHASE (208 VAC) EQUIPMENT WILL NOT OPERATE AND ALL PHASE INDICATOR LIGHTS ARE ON.

Step 1. Use a multimeter and check for correct output voltage at universal adapter. (WP 0027)

- (a) If correct voltage is present, perform power consuming equipment PMCS.
- (b) If correct voltage is not present, go to **Step 2**.

Step 2. Disconnect universal adapter input cable, use a multimeter and check for correct output voltage. (See WP 0027)

- (a) If correct voltage is present, go to **Step 3**.
- (b) If correct voltage is not present, go to **Step 4**.

Step 3. Check for continuity between universal adapter terminal lugs and connector pins. (WP 0027)

- (a) If continuity does not exist, notify next level of maintenance to repair universal adapter connector .

-
- Step 4.** Disconnect output cable at nearest center, use multimeter and check for correct output voltage.
- (a) If correct voltage is present, notify next level maintenance and replace cable.
 - (b) If correct voltage is not present, go to **Malfunction 1, Step 3** and continue troubleshooting.

MALFUNCTION
TEST OR INSPECTION
CORRECTIVE ACTION

4. USER'S 3-PHASE (208 VAC) EQUIPMENT WILL NOT OPERATE AND PHASE INDICATOR LIGHTS ARE OFF.

Perform troubleshooting steps in **Malfunction 2**.

5. CIRCUIT BREAKER SUPPORTING USER'S LOAD REPEATEDLY TRIPS.

CAUTION

Do not block circuit breakers in ON position.
Excessive current will damage DISE and PDISE equipment.

Step 1. Check that user's load requirements do not exceed center connector output rating.

- (a) If user's load requirements exceed circuit breaker rating, notify operator that load exceeds circuit breaker rating.
- (b) If the user's total load requirements are less than circuit breaker rating and circuit breaker still trips, replace circuit breaker (See WP 0018).

END OF WORK PACKAGE

Chapter 6

FIELD LEVEL MAINTENANCE

**FIELD LEVEL MAINTENANCE INSTRUCTIONS
DISE AND PDISE SYSTEMS
SERVICE UPON RECEIPT**

INITIAL SETUP:**Tools**

None

References

SF Form 364

DA PAM 750-1

TM 9-6150-226-24P

Materials/Parts

None

Personnel Required

One

Equipment Conditions

System is Shut Down

INTRODUCTION

MOS 52D, Power Generator Equipment Repairer, is authorized to perform all maintenance on DISE/PDISE equipment.

CHECKING UNPACKED EQUIPMENT.

- a. Inspect the equipment for damage incurred during shipment. If the equipment has been damaged, report the damage on SF Form 364, Report of Discrepancy.
- b. Check the equipment against the packing list to see if the shipment is complete.
- c. Report all discrepancies in accordance with the instructions of DA PAM 750-1.
- d. Check current publications to determine if equipment has been modified or is projected to be modified.

Table 1. SERVICE UPON RECEIPT CHECKLIST

Item	Location	Action	Remarks
1.	Feeder/distribution Centers	<ul style="list-style-type: none"> a. Inspect circuit breaker switches for freedom of movement. b. Inspect connectors for missing covers. c. Inspect connectors plugs for missing or bent pins. d. Inspect connector receptacles for distorted or damaged sockets e. Inspect phase lights for damaged or missing bulbs. f. Inspect for missing or damaged latches. 	
2.	Cables	<ul style="list-style-type: none"> a. Inspect for missing connector covers. b. Inspect for missing or bent connector pins. c. Inspect for distorted or damaged connector sockets. d. Inspect for split, cut, or damaged Insulation. 	
3.	Utility lights	<ul style="list-style-type: none"> a. Inspect for broken or damaged sockets. b. Inspect for missing plugs. c. Inspect for inoperable or damaged switches. d. Inspect for split, cut, or damaged cable insulation. 	
4.	Duplex Receptacle	<ul style="list-style-type: none"> a. Inspect for missing or damaged covers. b. Inspect for distorted or damaged connectors. 	

END OF WORK PACKAGE

**FIELD LEVEL MAINTENANCE INSTRUCTIONS
DISE and PDISE FEEDER/DISTRIBUTION SYSTEMS
PMCS INTRODUCTION**

INITIAL SETUP:**Tools**

None

Personnel Required

One

References

DA Form 2404

TM 43-0139

DA PAM 750-1

TM 38-230-1

WP 0011

WP 0013

WP 0031

GENERAL

Your PMCS table (WP 0013) has been provided so you can keep your equipment in good operating condition and ready for its primary mission. The PMCS contains those checks and services authorized to the Service Level by the maintenance allocation chart (MAC) under “inspection and service” functions.

MAINTENANCE INSTRUCTIONS

Always observe **WARNINGS** and **CAUTIONS** appearing in your PMCS table to prevent serious injury to yourself and others or to prevent your equipment from being damaged. These precautions have been placed before the applicable procedures. Some other important reminders include:

- Replace or repair defective components you discover during PMCS.
- To facilitate assembly and installation, apply identifying tags to mating points of electrical lines when they are disconnected. WP 0031 shows complete wiring diagrams for appropriate DISE and PDISE equipment.
- Remove only those parts requiring repair or replacement. Tag similar parts to ensure correct assembly. Do not disassemble a component any further than necessary to accomplish needed repairs.
- Refer to wiring diagrams and identifying tags when assembling DISE and PDISE equipment. Wires are marked to aid you in assembly of the feeder/distribution centers.

EXPLANATION OF TABLE ENTRIES

- (1) Item number column. Numbers in this column are for reference. When Completing DA Form 2404, Equipment Inspection and Maintenance Worksheet, include the item number for the check/service indicating a fault: Item numbers also appear in the order that you must do checks and services for the intervals listed.
- (2) Interval column. This column tells you when you must do the procedure in the procedure column.
- (3) Check/Service column. This column provides the location and the item to be checked or serviced.

- (4) Procedure column. This column gives the procedure you must do to check or service the item listed in the Check/Service column to know if the equipment is ready or available for its intended mission or for operation. You must do the procedure at the time state in the interval column.
- (5) Not fully mission capable if: column. Information in this column tells you what faults will keep your equipment from being capable of performing its primary mission. If you make check and service procedures that show faults listed in this column, do not operate the equipment. Follow standard operating procedures for maintaining the equipment or reporting equipment failure.
- (6) Other table entries . Information other than warnings, cautions, and notes appear in the PMCS table. Be sure to observe all special information appearing in your table.

PMCS INSTRUCTIONS.

NOTES

- All DISE and PDISE subsystems are similar and contain similar components. Subsystems are combined in the PMCS chart and component checks for similar items are shown under a signal heading.
- If the equipment must be kept in continuous operation, do only the procedures that can be done without disturbing operation. Make complete checks and services when equipment is shut down.
- If you discover a maintenance problem while performing PMCS, troubleshoot malfunctions contained in WP 0011. Report any malfunctions or failures on the proper DA Form 2404, Equipment Inspection and Maintenance Work Sheet, or refer to DA Pam 750-1.
- Corrosion Prevention and Control (CPC) of Army Materiel is a continuing concern. It is important that any corrosion problems with DISE and PDISE be reported so that the problem can be corrected and improvements can be made to prevent the problem in future items. While corrosion is typically associated with rusting of metals, it can also include deterioration of other materials, such as rubber and plastic. Unusual cracking, softening, swelling, or breaking to these materials may be a corrosion problem is identified, it can be reported using Standard Form 368, Product Quality Deficiency Report. The form should be submitted to the address Specified in DA Pam 750-1. Corrosion can be prevented and controlled by following PMCS procedures.

PAINTING.

- a. Remove rust, corrosion, and flaked and peeling paint. Ensure surfaces to be painted are dry. Refer to TM 38-230-1, Packaging of Materiel: Preservation.
- b. Use masking tape (item 10, App E) and mask connectors and data plates that are not to be painted.
- c. Use paint (item 7, App E) and paint surfaces as required to protect against deterioration. Refer to TM 43-0139, Painting Instructions for Army Materiel.

END OF WORK PACKAGE

**FIELD LEVEL MAINTENANCE INSTRUCTIONS
DISE and PDISE EQUIPMENT
PREVENTIVE MAINTENANCE CHECKS AND SERVICES (PMCS)**

INITIAL SETUP:**Tools**

General Mechanic's Automotive Tool Kit
(Item 1, WP 0035)

Personnel Required

One

Equipment Conditions

System shut down

References

DA Form 2404
DA PAM 750-1
WP 0003
WP 0040

NOTE

If the equipment must be kept in continuous operation, check and service only those items that can be checked and serviced without disturbing operation. Make the complete checks and services when the equipment can be shut down.

WARNING

High voltage is present in this equipment. DISE/PDISE support equipment using 120/208 VAC. Do not perform PMCS with the power on. Failure to adhere to warning may cause death or serious injury may result.

Table 1. Field Level PREVENTIVE MAINTENANCE CHECKS AND SERVICES (PMCS).

Item No.	Interval	Location Item to Check/Service	Procedure	Not fully Mission Capable if:
1	Semi-annually	Feeder/distribution centers, Internal wiring M40, M46, M60, M100, M200, M40 A/P, M60 A/P M100 A/P and M200 A/P	Check internal wiring for secure connections. Check for burnt insulation and signs of over-heating.	Wires not secured by lugs. Wires burnt.
2	Semi-annually	Circuit Breakers	Check for secure mounting.	Circuit breaker not secured
3	Semi-annually	Internal surfaces	Check for corrosion and mildew.	
4	Semi-annually	Connectors	Check for missing gasket or hardware and secure mounting in distribution center.	Connectors are damaged or gasket is missing or un-Serviceable.
5	Semi-annually	Circuit breaker and bus bar wire lugs	Check torque in accordance with WP 0040.	Circuit breakers Not secure to bus bar wire lug or screws loose or missing.
6	Semi-annually	Cable Connectors	Check gland nut behind cable connector to insure nut is tight.	Nuts are loose or missing.
7	Semi-annually	Bus bars	Check for secure mounting and signs of damage.	Screws loose or missing. Bus bar is broken.
8	Semi-annually	Phase indicator lights	Check for secure mounting, missing or broken bulbs, and missing or broken covers.	Mounting not secured. Bulbs are broken or missing.

END OF WORK PACKAGE

**FIELD LEVEL MAINTENANCE INSTRUCTIONS
DISE AND PDISE SYSTEM
PREPARATION FOR STORAGE**

INITIAL SETUP:**Tools**

General Mechanic's Automotive Tool Kit
(Item 1, WP 0035)

Equipment Conditions

None

Materials/Parts

Masking Tape (Item 10, WP 0038)
Paint, CARC (Item 7, WP 0038)

References

TM 38-230-2
SB 740-99-9
TM 38-230-1
TM 43- 0139
WP 0008
WP 0034
WP 0038

SCOPE.

- a. Instructions in this section apply to the DISE and PDISE equipment to prepare it for storage or shipment.
- b. Placement of equipment in administrative storage should be for short periods of time when a shortage of maintenance effort exists. Items should be in mission readiness within 24 hours or within the item factors as developed by the directing authority. During the storage period appropriate maintenance records should be kept.
- c. Before placing equipment in administrative storage, current maintenance services and Equipment Serviceable Criteria (ESC) evaluations should be completed. Shortcomings and deficiencies should be corrected, and all Modification Work Orders (MWOs) should be applied.
- d. Storage site selection. Inside is preferred for items selected for administrative storage. If inside storage is not available, trucks, vans, conex containers and other containers may be used.

PREPARATION FOR STORAGE OR SHIPMENT.

- a. Inspection. Perform preventive maintenance checks and services listed in applicable work package.
- b. Repair. Correct deficiencies noted during the inspection. Refer repairs beyond the scope of user/maintenance personnel to applicable maintenance level personnel.
- c. Cleaning. Refer to operator PMCS (WP 0008) for cleaning instructions.
- d. Painting.
 - (1) Remove rust, corrosion, and flaked and peeling paint. Ensure surfaces to be painted are dry. Refer to TM 38-230-1, Packaging of Material: Preservation.
 - (2) Mask connectors and data plates that are not to be painted with masking tape.
 - (3) Paint surface, as required, to protect against deterioration.

Refer to TM 43- 0139, Painting Instructions for Army Materiel.

- e. Packaging. Refer to TM 38-230-2, Packing.

END OF WORK PACKAGE

**FIELD LEVEL MAINTENANCE INSTRUCTIONS
LANYARD ASSEMBLY
REPLACE**

INITIAL SETUP:**Tools**

General Mechanic's Automotive Tool Kit
(Item 1, WP 0035)

References**Equipment Conditions**

Power shut down

REPLACE**CAUTION**

Failure to support the lid after lanyards are removed may result in damage to the hinges.

1. Remove screws (1), nuts (2), washers (3), and lanyards (4) from box and lid.
2. Install lanyard assembly (4) on box and lid and secure with washers (3), nuts (2), and screws (1).

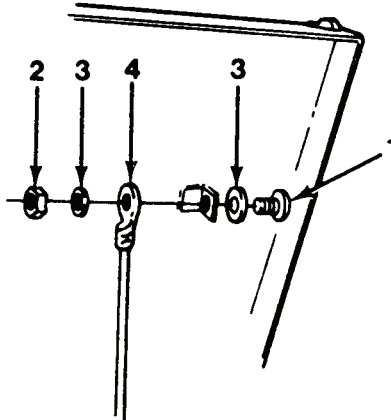

Figure 1. Lanyard Assembly

END OF WORK PACKAGE

**FIELD LEVEL MAINTENANCE INSTRUCTIONS
CIRCUIT BREAKER PANEL BOARD
REPLACE**

INITIAL SETUP:**Tools**

General Mechanic's Automotive Tool Kit
(Item 1, WP 0035),

References**Equipment Conditions**

Power Shut Down

Personnel Required

One

REPLACE**WARNING**

High voltage is present in this system. DISE and PDISE support equipment using 120/208 VAC. Do not replace a circuit breaker with the power on. Death or serious injury may result.

Circuit Breaker Panel (DISE only)

1. Remove screws (Figure 1, Item 1) securing inspection cover (Figure 1, Item 2) to distribution center. Remove inspection cover (2).

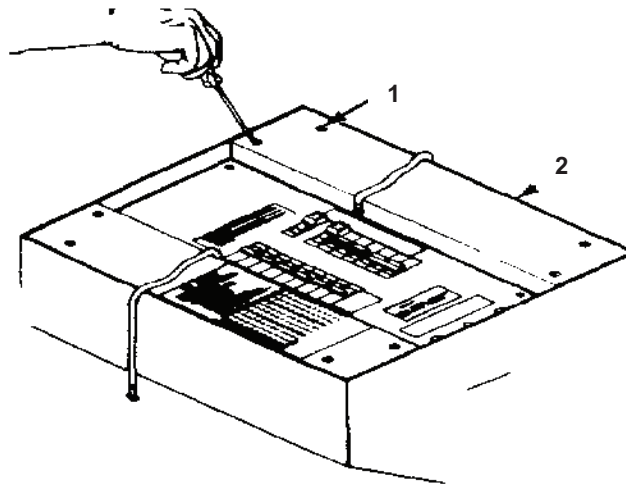

Figure 1. DISE Circuit Breaker Panel Board (1 of 2)

2. Remove screws (Figure 1, Item 3) securing panel to bus bar assembly.
3. Tag and disconnect phase indicator lights (Figure 1, Item 4) from circuit breaker and neutral bus bar.
4. Remove circuit breaker panel (Figure 1, Item 5).

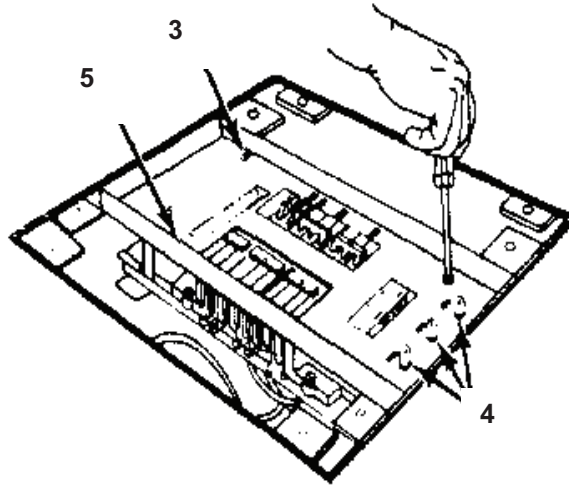

Figure 1. DISE Circuit Breaker Panel Board (2 of 2)

Circuit Breaker Panel (PDISE only)

1. Remove screws (Figure 2, Item 2) securing panel cover (Figure 2, Item 1) to distribution center.

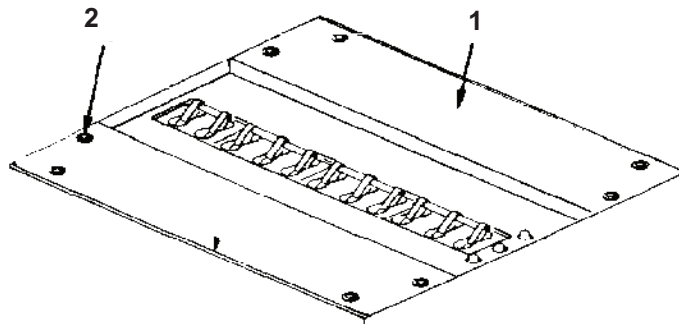

Figure 2. PDISE Circuit Breaker Panel Board

2. Install panel cover (1) and secure with screws (2).

END OF WORK PACKAGE

**FIELD LEVEL MAINTENANCE INSTRUCTIONS
PHASE INDICATOR LIGHT ASSEMBLY AND BULB.
REPLACE**

INITIAL SETUP:**Tools**

General Mechanic's Automotive Tool
Kit, (Item 1, WP 0035)

Reference

WP 0015
WP 0016
WP 0018

Equipment Conditions

Power shut down

REPLACE**WARNING**

High voltage is present in this system. DISE and PDISE support equipment using 120/208 VAC. Do not replace a connector assembly with the power on. Death or serious injury may result.

DISE only

1. Remove lanyard assembly (WP 0015).
2. Remove circuit breaker panels (WP 0016).
3. Disconnect phase light wiring from bus bar.
4. Invert circuit breaker panel and loosen/remove hardware (Figure 1, Item 1).
5. Lift out individual phase indicator light (Figure 1, Item 2) from front of panel.



Figure 1. Phase Indicator Light Assembly (1 of 2)

6. Insert phase indicator light (2) through front of panel.
7. Install and tighten hardware (1) on phase indicator light.
8. Connect phase light wiring to bus bar.
9. Install circuit breaker cover panels (WP 0016).
10. Install lanyard assembly (WP 0015).

PDISE only

1. Remove lanyard assembly (WP 0015).
2. Remove circuit breaker panels (WP 0016).
3. Remove circuit breaker assembly (WP 0018).
4. Disconnect phase light wiring assembly from bus bars.
5. Remove screws (Figure 1, Item 3), nuts (Figure 1, Item 4), and washers (Figure 1, Item 5) from light bracket mounting (Figure 1, Item 6).
6. Remove nut (7) and washer (8) from phase indicator light (9).
7. Lift out phase indicator light (9) from light bracket mounting (6).

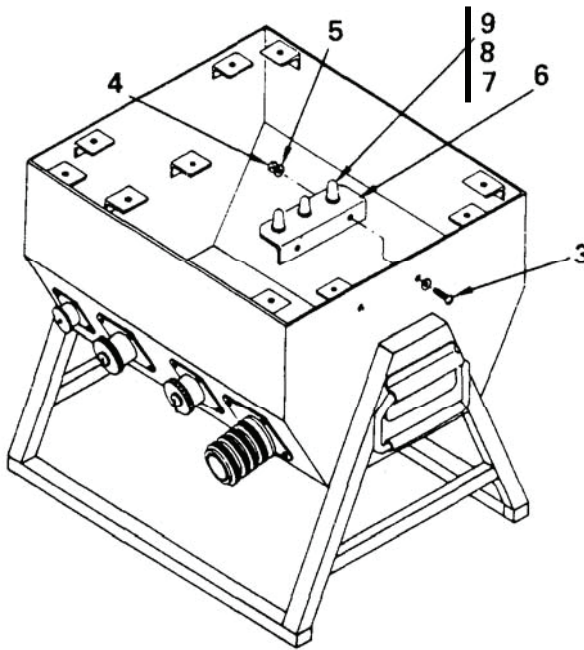

Figure 1. Phase Indicator Light Assembly (2 of 2)

8. Insert phase indicator light (9) through top of light bracket mounting (6).
9. Install washer (8) and tighten nut (7).
10. Install washers (5) and tighten nuts (4).
11. Install screws (3) in light bracket mounting (6) and tighten.
12. Connect phase light wire to bus bar.
13. Install circuit breaker assembly (WP 0018).
14. Install circuit breaker cover panels (WP 0016).
15. Install lanyard assembly (WP 0015).

BULB REPLACEMENT

Unscrew colored lens and replace bulb.

END OF WORK PACKAGE

**FIELD LEVEL MAINTENANCE INSTRUCTIONS
CIRCUIT BREAKER
REPLACE, TEST**

INITIAL SETUP:**Tools**

General Mechanic's Automotive Tool Kit
(Item 1, WP 0035)

Equipment Conditions

Power Shut Down

Reference

WP 0015
WP 0016
WP 0020
WP 0040

REPLACE**WARNING**

High voltage is present in this system. DISE and PDISE supports equipment using 120/208 VAC. Do not replace a circuit breaker with the power on. Failure to observe this may result in serious injury to personnel or equipment.

DISE

1. Remove lanyard assembly (WP 0015).
2. Remove circuit breaker and panel boards (WP 0016).
3. Tag and disconnect internal wiring from circuit breaker (Figure 1, Item 1).
4. Loosen screws (Figure 1, Item 3) securing circuit breaker (1) to bus bar assembly (Figure 1, Item 2).

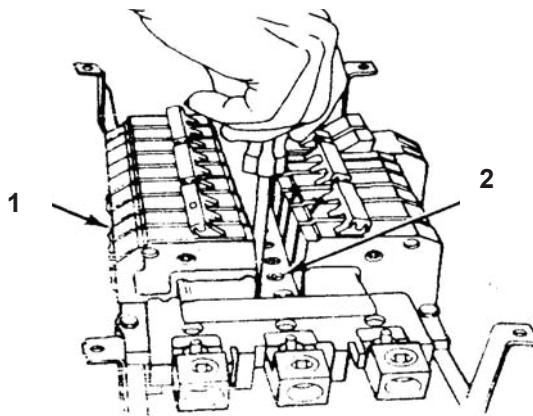

Figure 1. DISE Circuit Breaker (1 of 2)

5. Tilt circuit breaker (1) away from bus bar assembly (2) and remove circuit breaker (1).

NOTE

Circuit breaker support rails are marked with phase designations. All Breakers must be installed in the correct pole space in order to maintain proper phases.

6. Hook circuit breaker (1) on support rail, swing down into place, and secure with screws (3).
7. Connect internal wiring to circuit breaker (1) and remove tags.
8. Torque circuit breaker lug in accordance with WP 0040 specifications.

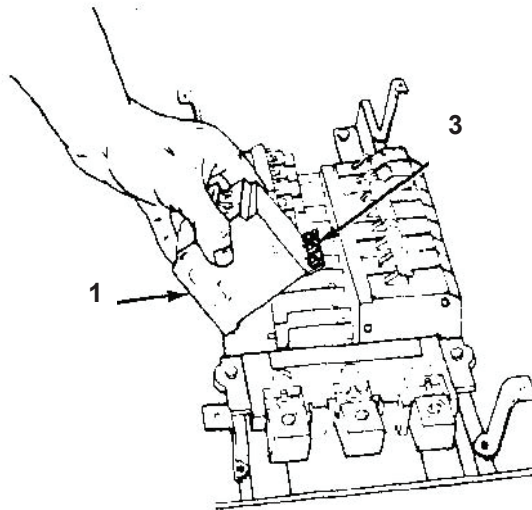

Figure 1. DISE Circuit Breaker (2 of 2)

9. Install circuit breaker panel board (WP 0016).
10. Install lanyard assembly (WP 0015).

PDISE

1. Remove lanyard assembly (WP 0015).
2. Remove circuit breaker and panel boards (WP 0016).
3. Tag and disconnect internal wiring (Figure 2, Item 1) from circuit breaker (Figure 2, Item 2).
4. Remove screws (Figure 2, Item 3) securing circuit breakers (2) to support rails.
5. Remove circuit breakers (2) from support rails

NOTE

Circuit breaker support rails are marked with phase designations. All Breakers must be installed in the correct pole space in order to maintain proper phases.

6. Place circuit breaker (2) on support rails and secure with screws (3).
7. Connect internal wiring (1) to circuit breaker and remove tags.

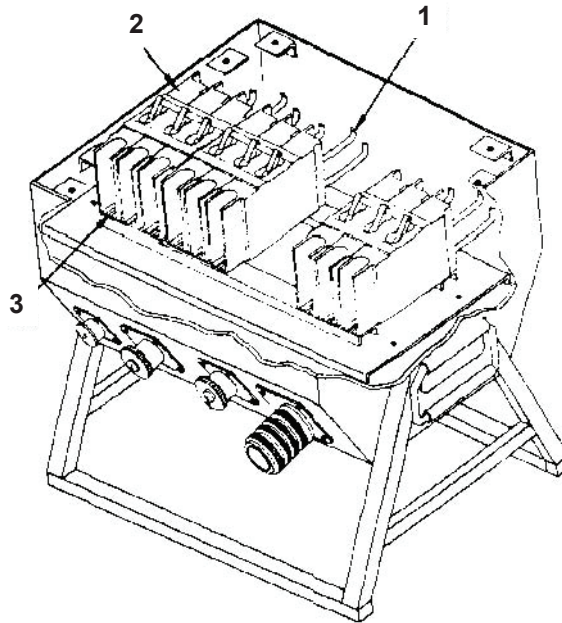

Figure 2. PDISE Circuit Breaker (1 of 2)

8. Torque circuit breaker wire lug (Figure 2, Item 4) in accordance with WP 0040 specifications.

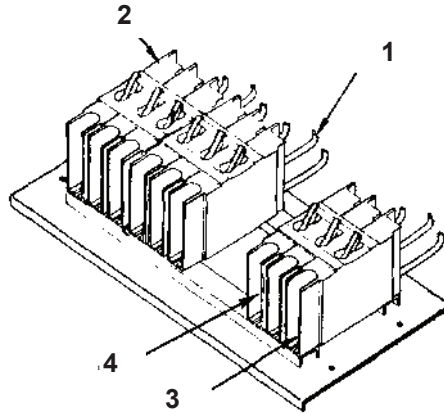

Figure 2. PDISE Circuit Breaker (2 of 2)

9. Install circuit breaker and panel boards (WP 0016).
10. Install lanyard assembly (WP 0015).

TEST

NOTE

Circuit breaker support rails are marked with phase designations. All breakers must be installed in the correct pole space in order to maintain proper phases.

1. For **DISE** circuit breaker, (with circuit breaker removed), open circuit breaker and check for no continuity.
2. Close breaker and check for continuity.
 - If either reading is incorrect, replace circuit breaker per this WP.
3. For **PDISE** circuit breaker, (with circuit breaker removed), perform continuity test on feeder/distribution center (WP 0020).

END OF WORK PACKAGE

**FIELD LEVEL MAINTENANCE INSTRUCTIONS
CIRCUIT BREAKER AND BUS BAR ASSEMBLY
REPLACE, TEST**

INITIAL SETUP:**Tools**

General Mechanic's Automotive Tool Kit
(Item 1, WP 0035)

Equipment Conditions

Power Shut Down

Materials/Parts

Kester Solder (Item 17, WP 0038)

Reference

WP 0003
WP 0015
WP 0016
WP 0017
WP 0018
WP 0040

REPLACE**WARNING**

High voltage is present in this system. DISE and PDISE supports equipment using 120/208 VAC. Do not replace a circuit breaker with the power on. Failure to observe this may result in serious injury to personnel or equipment.

DISE (Circuit Breaker Assembly and Bus Bar Terminal)**CAUTION**

Ground fault circuit breaker (DISE only) has the panel neutral wire permanently attached inside the circuit breaker. Disconnect this wire at the bus bar.

1. Remove lanyard assembly (WP 0015).
2. Remove circuit breaker and panel boards (WP 0016).
3. Tag and disconnect wiring from circuit breakers and bus bars.
4. Remove screw (Figure 1, Item 1) securing circuit breaker assembly (Figure 1, Item 2).

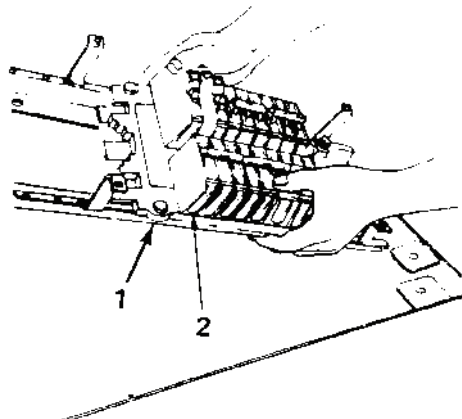

Figure 1. DISE Circuit Breaker Assembly

5. Remove circuit breaker assembly (2) from feeder/distribution center.

NOTE

When removing ground bus bar, disconnect and remove ground strap connecting bus bar to enclosure.

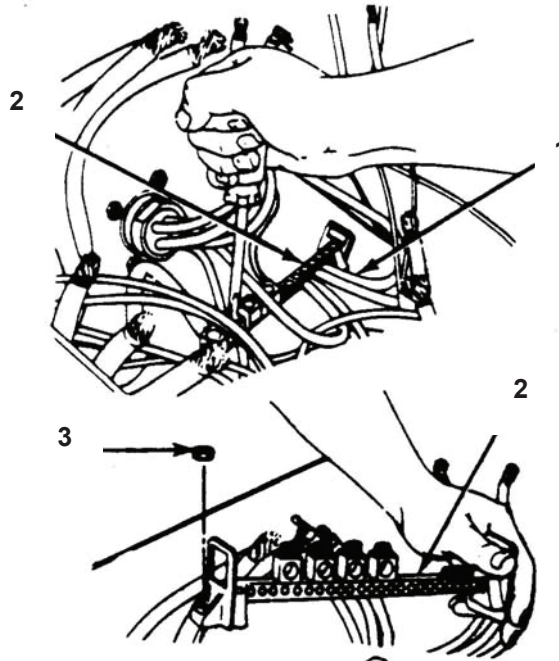

Figure 2. DISE Bus Bar Terminal (1 of 2)

6. Tag and disconnect wiring (Figure 2, Item 1) from bus bar terminals (Figure 2, Item 2).
7. Remove nut (Figure 2, Item 3) securing bus bar (2) to feeder/distribution center and remove bus bar.
8. Install bus bar (2) and secure with nut (3).
9. Solder dip or solder gun wire ends, not to exceed .025 inches, using Kester Solder MIL Spec No.QQ-S-571.
10. Secure phase bus bars (Figure 2, Item 5) with screws (Figure 2, Item 6).
11. Refer to tags and connect wiring (Figure 2, Item 4) to bus bars (2).
12. Remove tags and torque terminal lugs in accordance with WP 0040 specifications.

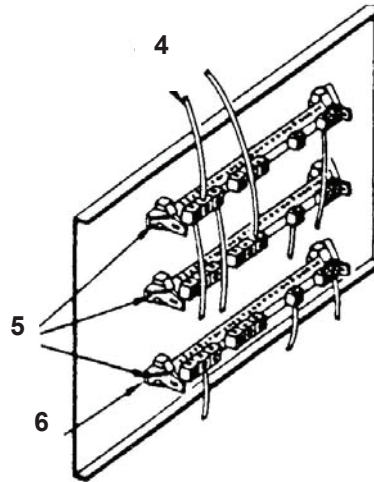

Figure 2. Bus Bar Terminal (2 of 2)

13. Install circuit breaker assembly (Figure 1, Item 2) and secure with screws (Figure 1, Item 1).
14. Solder dip or solder gun wire ends, not to exceed .025 inches, using MIL SPEC No. QQ-S-571.
15. Refer to tags and connect wiring to circuit breakers.
16. Remove tags and torque in accordance with WP 0039 specifications.
17. Install circuit breakers and panel boards (WP 0018, WP 0016).
18. Install lanyard assembly (WP 0015).
19. Place unit in normal operation (WP 0003).

PDISE (Circuit Breaker Assembly and Bus Bar Terminal)

1. Remove lanyard assembly (WP 0015).
2. Remove circuit breaker and panel boards (WP 0018, WP 0016).
3. Remove phase indicator light assembly (WP 0017)

NOTE

M60 A/P has only Phase A.

4. Tag and disconnect wiring J1-A, B, C (Figure 3, Item 1) from circuit breaker 1 (Figure 3, Item 2).

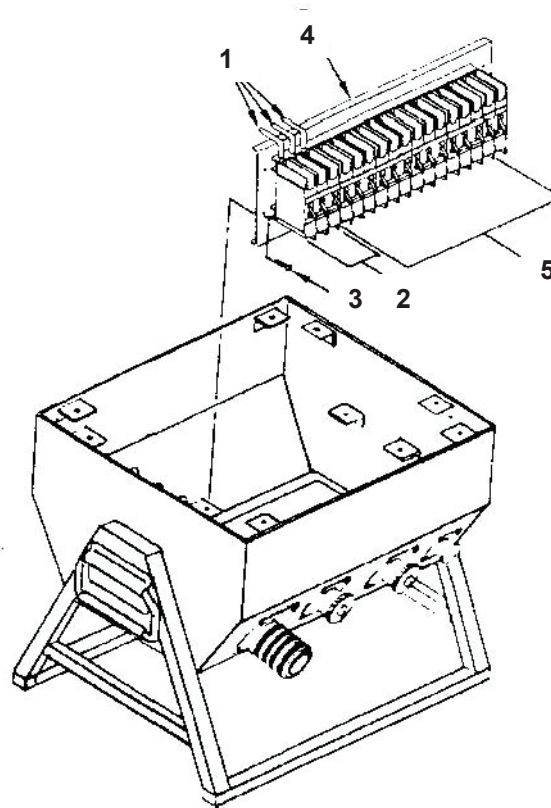

Figure 3. PDISE Circuit Breaker Assembly

5. Remove screws (Figure 3, Item 3) securing circuit breaker assembly (Figure 3, Item 4).

NOTE

On model M100 A/P, remove circuit breaker 8 for access to mounting screw.

6. Tag and disconnect wiring from circuit breakers {3, 4, 5, 6, 7, 8} (Figure 3, Item 5) and J2-A, B, and C from bus bars L1, L2, and L3.
7. Tilt circuit breaker assembly (4) clockwise for exposure.
8. Tag and disconnect wiring (Figure 2, Item 4) from 3 phase bus bars (Figure 2, Item 5).
9. Remove screws (Figure 2, Item 6) securing bus bars and remove bus bars (5).
10. Tag and disconnect wiring (Figure 4, Item 1) from ground (Figure 4, Item 2) and neutral (Figure 4, Item 3) bus bars.

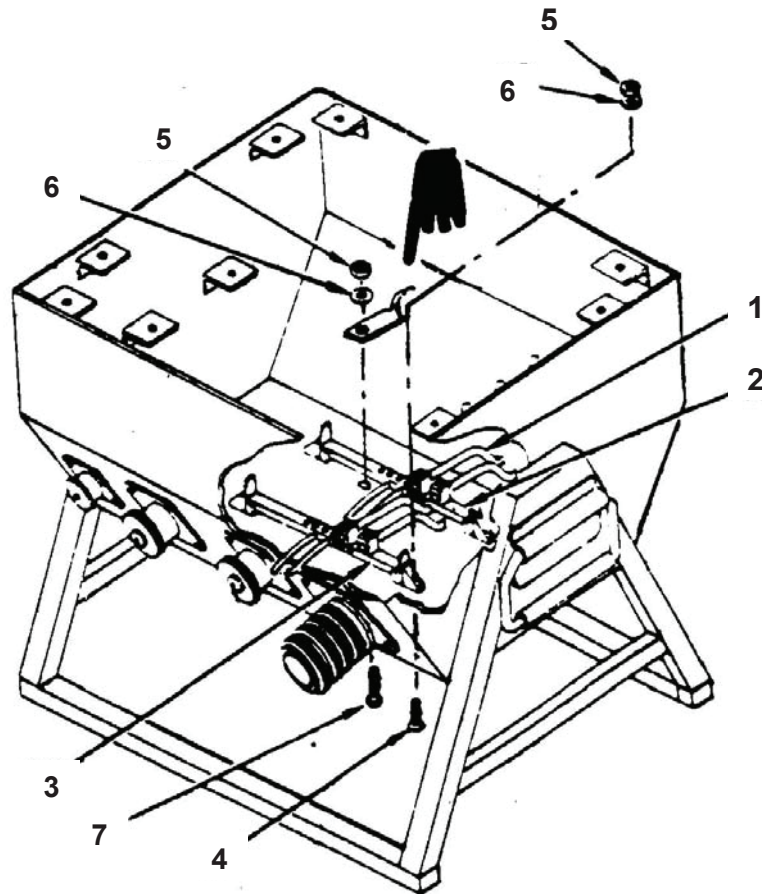

Figure 4. PDISE Bus Bar and Grounding Strap

11. Remove screws (Figure 4, Item 4), nuts (Figure 4, Item 5) and washers (Figure 4, Item 6) securing bus bar. Remove bus bars.
12. Remove screw (Figure 4, Item 7), nut (5) and washer (6) securing ground strap.
13. Refer to tags and connect wiring (Figure 2, Item 4) to bus bar terminals (Figure 2, Item 5).
14. Remove tags and torque terminals in accordance with WP 0040 specifications.
15. Install neutral (Figure 4, Item 3), and ground (Figure 4, Item 2) bus bars and secure with screws (Figure 4, Item 4), washers (Figure 4, Item 6), and nuts (Figure 4, Item 5).
16. Install screw (Figure 4, Item 7), washer (6) and nut (5) securing ground strap.
17. Refer to tags and connect wiring (Figure 4, Item 1) to bus bars.
18. Refer to tags and connect receptacle/plug wiring to circuit breakers.
19. Remove tags and torque in accordance with WP 0040 specifications.

NOTE

Do not secure circuit breaker assembly if performing continuity test.

20. Connect wiring J2-A, B, and C to bus bars.
21. Install circuit breaker assembly (Figure 3, Item 4) and secure with screws (Figure 3, Item 3).
22. Install phase indicator light assembly (WP 0017)
23. Install circuit breaker and panel boards (WP 0018, WP 0016).
24. Install lanyard assembly (WP 0015).
25. Place equipment back into normal operation. (WP 0003)

TEST**WARNING**

High voltage is present in this system. DISE and PDISE supports equipment using 120/208 VAC. Do not replace a circuit breaker with the power on. Failure to observe this may result in serious injury to personnel or equipment.

Refer to WP 0020 to perform continuity test on the applicable feeder/distribution center.

Ground Fault Circuit Interrupter (GFCI)**NOTE**

The circuit breakers on the **DISE ONLY** panel that contain a "PUSH TO TEST" button are of the "GFCI" type. Each GFCI breaker should be tested at the beginning of each setup, at monthly intervals, and following any continuous operation.

1. Connect power source to the input connector.
2. Turn on the main circuit breaker.
3. Turn on the GFCI circuit breaker.
4. Push the "Push to Test Button" and ensure that breaker trips.
 - If breaker does not trip, replace GFCI as per this WP.

END OF WORK PACKAGE

**FIELD LEVEL MAINTENANCE INSTRUCTIONS
FEEDER/DISTRIBUTION CONNECTOR ASSEMBLY
REPLACE, TEST**

INITIAL SETUP:**Tools**

General Mechanic's Automotive Tool Kit
(Item 1, WP 0035)

Equipment Conditions

Power shut down

Reference

WP 0015
WP 0016
WP 0019
WP 0040

Personnel Required

One

REPLACE

The following procedures are only to separate/disconnect the connector "assembly" from the circuit breaker and the enclosure assembly. For repair of Feeder/Distribution connectors, proceed to next level maintenance.

WARNING

High voltage is present in this system. DISE and PDISE support equipment using 120/208 VAC. Do not replace a connector assembly with the power on. Failure to observe warning may result in death or serious injury to personnel.

NOTE

When disconnecting or connecting wires to bus bar terminal, it is necessary to remove circuit breaker assembly for PDISE.

1. Remove lanyards assembly (WP 0015).
2. Remove circuit breaker panel covers (WP 0016).
3. Remove circuit breaker assembly (WP 0019).
4. Tag and disconnect receptacle/plug wiring from circuit breaker and bus bar terminals.
5. Remove screw (Figure 1, Item 1) securing receptacle/plug and gasket (Figure 1, Item 2) and remove connector,
6. Install receptacle/plug and gasket (2) in mounting hole and secure with screw (1).
7. Connect receptacle/plug wiring and remove tags.
8. Torque terminal lugs in accordance with WP 0040 specifications.
9. Install circuit breaker assembly (WP 0019).

10. Install circuit breaker panel covers. (WP 0016)

11. Install lanyard assembly (WP 0015).

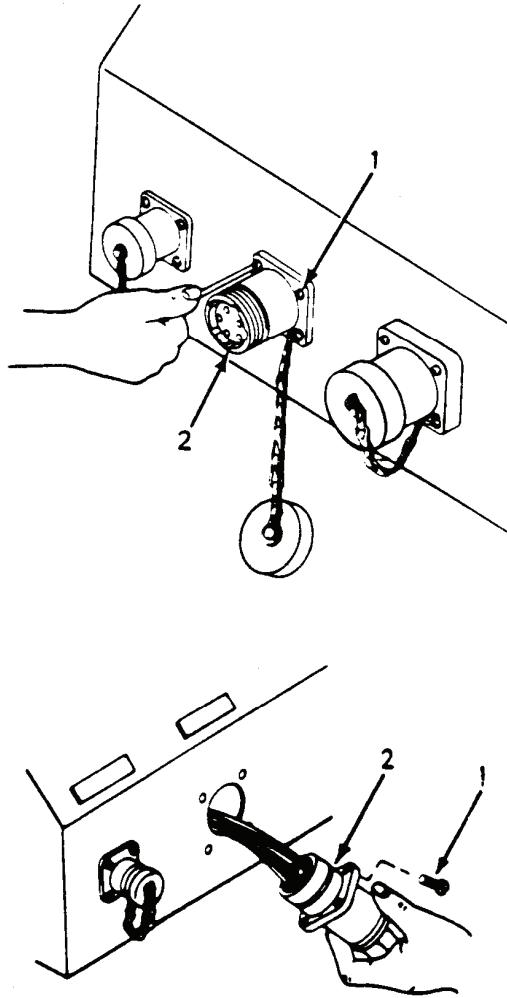

Figure 1. Feeder/Distribution Connector Assembly

TEST**WARNING**

High voltage is present in this system. DISE and PDISE support equipment using 120/208 VAC. Do not replace a circuit breaker with the power on. Death or serious injury may result.

NOTE

All checks are made with circuit breakers closed.

Perform continuity test on the applicable feeder/distribution connector found in one of the Tables below. See WP 0031 for Wiring Diagrams.

Table 1. M 200 Feeder Center and M200 A/P Feeder Center

NOTE

X indicates continuity.
0 indicates no continuity.

	Phase A (L1)	Phase B (L2)	Phase C (L3)	Neutral (LO)	Ground
J1- A	x	0	0	0	0
J1- B	0	x	0	0	0
J1- C	0	0	x	0	0
J1- N	0	0	0	x	0
J1-G1	0	0	0	0	x
J1-G2	0	0	0	0	x
J1-G3	0	0	0	0	x
J1-G4	0	0	0	0	x
J4- A	x	0	0	0	x
J4- B	0	x	0	0	0
J4- C	0	0	x	0	0
J4- N	0	0	0	x	0
J4-G1	0	0	0	0	x
J4-G 2	0	0	0	0	x
J4-G3	0	0	0	0	x
J4-G4	0	0	0	0	x
J5- A	x	0	0	0	0
J5- B	0	x	0	0	0
J5- C	0	0	x	0	0
J5- N	0	0	0	x	0
J5-G1	0	0	0	0	x
J5-G 2	0	0	0	0	x
J5-G 3	0	0	0	0	x
J5-G 4	0	0	0	0	x
J6-A	0	x	0	0	0
J6-B	0	0	0	x	0
J6-C	0	0	0	0	x

Table 1 (Cont.) M 200 Feeder Center and M200 A/P Feeder Center

NOTE

X indicates continuity.
0 indicates no continuity.

	Phase A (L1)	Phase B (L2)	Phase C (L3)	Neutral (LO)	Ground (G)
J7-A	x	0	0	0	0
J7-B	0	x	0	0	0
J7-C	0	0	x	0	0
J7-N	0	0	0	x	0
J7-G	0	0	0	0	x
J8-A	x	0	0	0	0
J8-B	0	x	0	0	0
J8-C	0	0	x	0	0
J8-N	0	0	0	x	0
J8-G	0	0	0	0	x
J9-A	x	0	0	0	0
J9-B	0	x	0	0	0
J9-C	0	0	x	0	0
J9-N	0	0	0	x	0
J9-G	0	0	0	0	x
J10-A	x	0	0	0	0
J10-B	0	x	0	0	0
J10-C	0	0	x	0	0
J10-N	0	0	0	x	0
J10-G	0	0	0	0	x
J11-A	x	0	0	0	0
J11-B	0	x	0	0	0
J11-C	0	0	x	0	0
J11-N	0	0	0	x	0
J11-G1	0	0	0	0	x
J11-G2	0	0	0	0	x
J11-G3	0	0	0	0	x
J11-G4	0	0	0	0	x

Table 2. M100 Feeder Center and M100 A/P Feeder Center.

NOTE

X indicates continuity.
0 indicates no continuity

	Phase A (L1)	Phase B (L2)	Phase C (L3)	Neutral (LO)	Ground (G)
J1- A	x	0	0	0	0
J1- B	0	x	0	0	0
J1- C	0	0	x	0	0
J1- N	0	0	0	x	0
J1-G1	0	0	0	0	x
J1-G2	0	0	0	0	x
J1-G3	0	0	0	0	x
J1-G4	0	0	0	0	x
J2- A	x	0	0	0	x
J2- B	0	x	0	0	0
J2- C	0	0	x	0	0
J2- N	0	0	0	x	0
J2-G1	0	0	0	0	x
J2-G2	0	0	0	0	x
J2-G3	0	0	0	0	x
J2-G4	0	0	0	0	x
J3- A	x	0	0	0	0
J3- B	0	x	0	0	0
J3- C	0	0	x	0	0
J3- N	0	0	0	x	0
J3-G	0	0	0	0	x
J4-A	x	0	0	0	0
J4-B	0	x	0	0	0
J4-C	0	0	x	0	0
J4-N	0	0	0	x	0
J4-G	0	0	0	0	x
J5-A	x	0	0	0	0
J5-B	0	x	0	0	0
J5-C	0	0	x	0	0
J5-N	0	0	0	x	0
J5-G	0	0	0	0	x

Table 2 (Cont). M100 Feeder Center and M100 A/P Feeder Center

NOTE

X indicates continuity.
 0 indicates no continuity.

	Phase A (L1)	Phase B (L2)	Phase C (L3)	Neutral (LO)	Ground (G)
J6-A	x	0	0	0	0
J6-B	0	x	0	0	0
J6-C	0	0	x	0	0
J6-N	0	0	0	x	0
J6-G	0	0	0	0	x
J7-A	0	0	x	0	0
J7-B	0	0	0	x	0
J7-C	0	0	0	0	x
J8-A	x	0	0	0	0
J8-B	0	0	0	x	0
J8-C	0	0	0	0	x

Table 3. M40 Distribution Center and M40 A/P Distribution Center.

NOTE

X indicates continuity.
 0 indicates no continuity.

	Phase A (L1)	Phase B (L2)	Phase C (L3)	Neutral (LO)	Ground (G)
J1-A	x	0	0	0	0
J1-B	0	x	0	0	0
J1-C	0	0	x	0	0
J1-N	0	0	0	x	0
J1-G	0	0	0	0	x
J2-A	x	0	0	0	0
J2-B	0	x	0	0	0
J2-C	0	0	x	0	0
J2-N	0	0	0	x	0
J2-G	0	0	0	0	x
J3-A	0	0	x	0	0
J3-B	0	0	0	x	0
J3-C	0	0	0	0	x
J4-A	0	0	x	0	0
J4-B	0	0	0	x	0
J4-C	0	0	0	0	x
J5-A	0	x	0	0	0
J5-B	0	0	0	x	0
J5-C	0	0	0	0	x
J6-A	0	x	0	0	0
J6-B	0	0	0	x	0
J6-C	0	0	0	0	x
J7-A	x	0	0	0	0
J7-B	0	0	0	x	0
J7-C	0	0	0	0	x

Table 3 (Cont.). M40 Feeder Center and M40 A/P Feeder Center

NOTE

X indicates continuity.
0 indicates no continuity.

	Phase A (L1)	Phase B (L2)	Phase C (L3)	Neutral (LO)	Ground (G)
J8-A	x	0	0	0	0
J8-B	0	0	0	x	0
J8-C	0	0	0	0	x
J9-A	0	0	x	0	0
J9-B	0	0	0	x	0
J9-C	0	0	0	0	x
J10-A	0	0	x	0	0
J10-B	0	0	0	x	0
J10-C	0	0	0	0	x
J11-A	0	x	0	0	0
J11-B	0	0	0	x	0
J11-C	0	0	0	0	x
J12-A	0	x	0	0	0
J12-B	0	0	0	x	0
J12-C	0	0	0	0	x
J13-A	x	0	0	0	0
J13-B	0	0	0	x	0
J13-C	0	0	0	0	x
J14-A	x	0	0	0	0
J14-B	0	0	0	x	0
J14-C	0	0	0	0	x

Table 4. M60 Distribution Center and M60 A/P Distribution Center.

NOTE

X indicates continuity.
0 indicates no continuity.

	Phase A (L1)	Neutral (LO)	Ground (G)
J1-A	x	0	0
J1-N	0	x	0
J1-G1	0	0	x
J1-G2	0	0	x
J2-A	x	0	0
J2-N	0	x	0
J2-G1	0	0	x
J2-G2	0	0	x
J3-A	x	0	0
J3-B	0	x	0
J3-C	0	0	x
J4-A	x	0	0
J4-B	0	x	0
J4-C	0	0	x
J5-A	x	0	0
J5-B	0	x	0
J5-C	0	0	x
J6-A	x	0	0
J6-B	0	x	0
J6-C	0	0	x
J7-A	x	0	0
J7-B	0	x	0
J7-C	0	0	x
J8-A	x	0	0
J8-B	0	x	0
J8-C	0	0	x

END OF WORK PACKAGE

**FIELD LEVEL MAINTENANCE INSTRUCTIONS
DISE AND PDISE AUXILIARY CABLE ASSEMBLIES
TEST**

INITIAL SETUP:

Tools

General Mechanic's Automotive Tool Kit
(Item 1, WP 0035)

References

Equipment Conditions

None

Personnel Required

One

WARNING

High voltage is present in this system. DISE and PDISE support equipment using 120/208 VAC. Do not replace a connector assembly with the power on. Failure to observe warning may result in death or serious injury to personnel.

TEST

1. Disconnect both ends of cable from the DISE or PDISE equipment.
2. Refer to the applicable Table below and perform a continuity test on that cable.
3. If cable is defective, send to next higher level of maintenance.

NOTE

The following lists only the Service, Extension, Pigtail, and Branch cable assemblies.

<u>Table #</u>	<u>Auxiliary Cable Assembly Continuity Checks</u>
1.....	200/100 Amp, 8 Pin/Wire Service/Feeder Cables
2.....	40/60 Amp, 5 Pin/Wire Service/Feeder Cables
3.....	200/100 Amp, 8 Pin/Wire Pigtail Cables
4.....	40/60 Amp, 5 Pin/Wire Pigtail Cables
5.....	60-Amp, 4 Pin/Wire Service/Feeder Cables
6.....	60-Amp, 4 Pin/Wire Pigtail Cables
7.....	20-Amp, 3 Pin/Wire Extension Cables
8	20-Amp, 3 Pin/Wire Branch Circuit Cables

WARNING

High voltage is present in this system. DISE and PDISE systems support equipment using 120/208 V ac. Do not rely on the color of the wire insulation for phase color coding. The insulation on the wires inside the cable jacket may vary depending on supplier. Wires will be color coded to designate the phases. Perform a continuity test to verify phase designation is in accordance with identified color.

NOTE

X indicates continuity

0 indicates no continuity

Table 1. 200/100-Amp, 8 Pin/Wire Service/Feeder Cables.

	P1-A	P1-B	P1-C	P1-N	P1-G1	P1-G2	P1-G3	P1-G4
P2-A	x	0	0	0	0	0	0	0
P2-B	0	x	0	0	0	0	0	0
P2-C	0	0	x	0	0	0	0	0
P2-N	0	0	0	x	0	0	0	0
P2-G1	0	0	0	0	x	x	x	x
P2-G2	0	0	0	0	x	x	x	x
P2-G3	0	0	0	0	x	x	x	x
P2-G4	0	0	0	0	x	x	x	x

Table 2. 40/60-Amp, 5 Pin/Wire Service/Feeder Cables.

	P1-A	P1-B	P1-C	P1-N	P1-G
P2-A	x	0	0	0	0
P2-B	0	x	0	0	0
P2-C	0	0	x	0	0
P2-N	0	0	0	x	0
P2-G	0	0	0	0	x

NOTE

If tags are missing, perform continuity checks and tag wires according to appropriate color code.

Table 3. 200/100 - Amp, 8 Pin/Wire Pigtail Cables.

	P1-A	P1-B	P1-C	P1-N	P1-G1	P1-G2	P1-G3	P1-G4
black	x	0	0	0	0	0	0	0
red	0	x	0	0	0	0	0	0
blue	0	0	x	0	0	0	0	0
white	0	0	0	x	0	0	0	0
green/bare	1	0	0	0	0	x	x	x
green/bare	2	0	0	0	0	x	x	x
green/bare	3	0	0	0	0	x	x	x
green/bare	4	0	0	0	0	x	x	x

Table 4. 40/60 Amp, 5 Pin/Wire Pigtail Cables.

	P1-A	P1-B	P1-C	P1-N	P1-G1
black	x	0	0	0	0
red	0	x	0	0	0
blue	0	0	x	0	0
white	0	0	0	x	0
green/bare	0	0	0	0	0

Table 5. 60-amp, 4 Pin/Wire Service/Feeder Cables.

	P1-A	P1-N	P1-G1	P1-G2
P2-A	x	0	0	0
P2-N	0	x	0	0
P2-G1	0	0	x	0
P2-G2	0	0	0	x

Table 6. 60-Amp, 4 Pin/Wire Pigtail Cables.

	P1-A	P1-N	P1-G1	P1-G2
blk	x	0	0	0
wht	0	x	0	0
grn/bare 1	0	0	x	x
grn/bare 2	0	0	x	x

Table 7. 20-Amp, 3 Pin/Wire Extension Cables

	P1-A	P1-B	P1-C
P2-A	x	0	0
P2-B	0	x	0
P2-C	0	0	x

Table 8. 20-Amp, 3 Pin/Wire Branch Circuit Cables.

	P1-A	P1-B	P1-C
P2-A	x	0	0
P2-B	0	x	0
P2-C	0	0	x
P3-A	x	0	0
P3-B	0	x	0
P3-C	0	0	x
P4-A	x	0	0
P4-B	0	x	0
P4-C	0	0	x
P5-A	x	0	0
P5-B	0	x	0
P5-C	0	0	x

END OF WORK PACKAGE

**FIELD LEVEL MAINTENANCE INSTRUCTIONS
DUST AND MOISTURE SLEEVE
REPLACE**

INITIAL SETUP:**Tools**

General Mechanic's Automotive Tool Kit
(Item 1, WP 0035)

References**Materials/Parts**

None

Equipment Conditions

None

WARNING

High voltage is present in this system. DISE and PDISE support equipment using 120/208 VAC. Do not replace a connector assembly with the power on. Failure to observe warning may result in death or serious injury to personnel.

REPLACE

1. Remove nuts (Figure 1, Item 1), flat washers (Figure 1, Item 2), and screws (Figure 1, Item 3) securing sleeve plate (Figure 1, Item 4) to enclosure.
2. Remove locknut (Figure 1, Item 5) and bushing (Figure 1, Item 6).
3. Remove sleeve plate (4).
4. Remove dust and moisture sleeve (Figure 1, Item 7).
5. Install dust and moisture sleeve (7) and secure with sleeve plate (4), locknut (5), and bushing (6).
6. Secure sleeve plate (4) with nuts (1), flat washers (2), and screws (3).

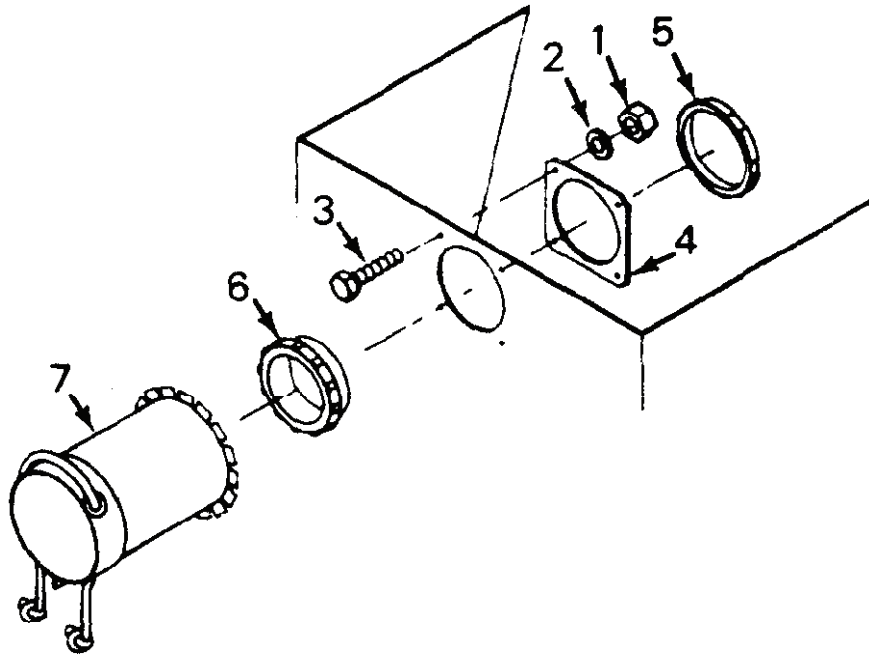

Figure 1. Dust and Moisture Sleeve

END OF WORK PACKAGE

FIELD LEVEL MAINTENANCE INSTRUCTIONS
GASKET
REPLACE

INITIAL SETUP:**Tools**

General Mechanic's Automotive Tool Kit
(Item 1, WP 0035)

References

WP 0015

Materials/Parts

Gasket Cement (item 1, WP 0038)

Equipment Conditions

Power shut down

REPLACE

1. Remove lanyards (WP 0015).
2. Scrape off old gasket (1).
3. Clean surface of lid with solvent and rag
4. Coat surface of gasket (1) with adhesive.
5. On hinged end of lid, place gasket (1) on inside of lip (2).
6. Place gasket (1) on bottom of lid for other three sides.
7. Install lanyards (WP 0015).

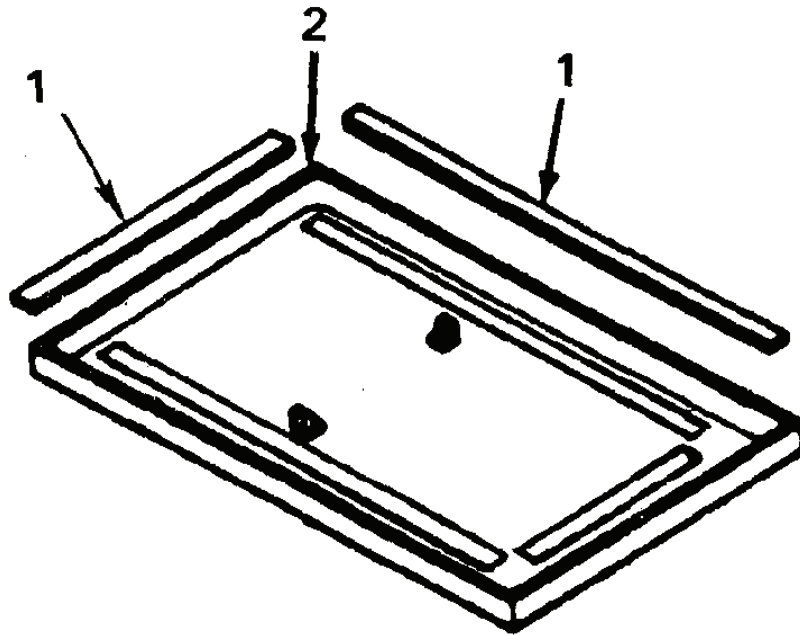

Figure 1. Gasket

END OF WORK PACKAGE

**SERVICE LEVEL MAINTENANCE INSTRUCTIONS
 DUPLEX RECEPTACLE GROUP AND CABLE
 REPLACE, TEST**

INITIAL SETUP:**Tools**

General Mechanic's Automotive Tool Kit
 (Item 1, WP 0035)

References**Materials/Parts**

None

Equipment Conditions

Power shut down

REPLACE**WARNING**

High voltage is present in this system. DISE and PDISE support equipment using 120/208 VAC. Do not replace a connector assembly with the power on or serious injury may result.

1. Remove screws (1) and remove door assembly (2).
2. Remove screws (3) and remove duplex receptacle (4) from door assembly (2).
3. Tag and disconnect wires.
4. Loosen gland nut (5) and remove gland (6).
5. Remove cable assembly (7) from receptacle box.
6. Replace defective parts as necessary.

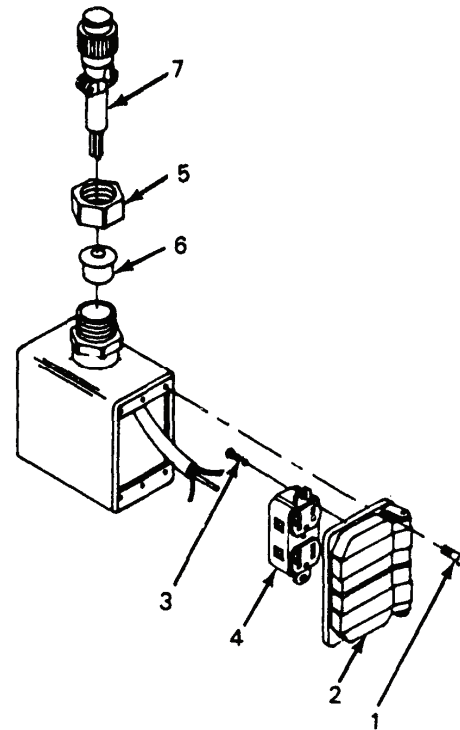

Figure 1. Receptacle Box

7. Install cable assembly (7) in receptacle box.
8. Install gland (6) in place and secure with gland nut (5).
9. Remove tags and connect wires in accordance with Figure 2.
10. Install duplex receptacle (4) on door assembly (2) and secure with screws (3).
11. Place door assembly (2) on box and secure with screws.

TEST

WARNING

High voltage is present in this system. DISE and PDISE support equipment using 120/208 VAC. Do not attempt continuity checks with the power on or serious injury may result. Failure to do so may result in death or serious injury or equipment damage.

Refer to the following table to perform continuity test on the duplex receptacle.

Table 1. DUPLEX RECEPTACLE CONTINUITY CHECKS (see Figure 2)

NOTE

X indicates continuity.

0 indicates no continuity.

Input Connector	Phase Line (Black Wire) (Short Slot)	Duplex Receptacle Neutral Line (White Wire) (Long T-slot)	Ground Line (Green Wire) (Ground slot)
J1-A	x	0	0
J1-B	0	x	0
J1-C	0	0	X

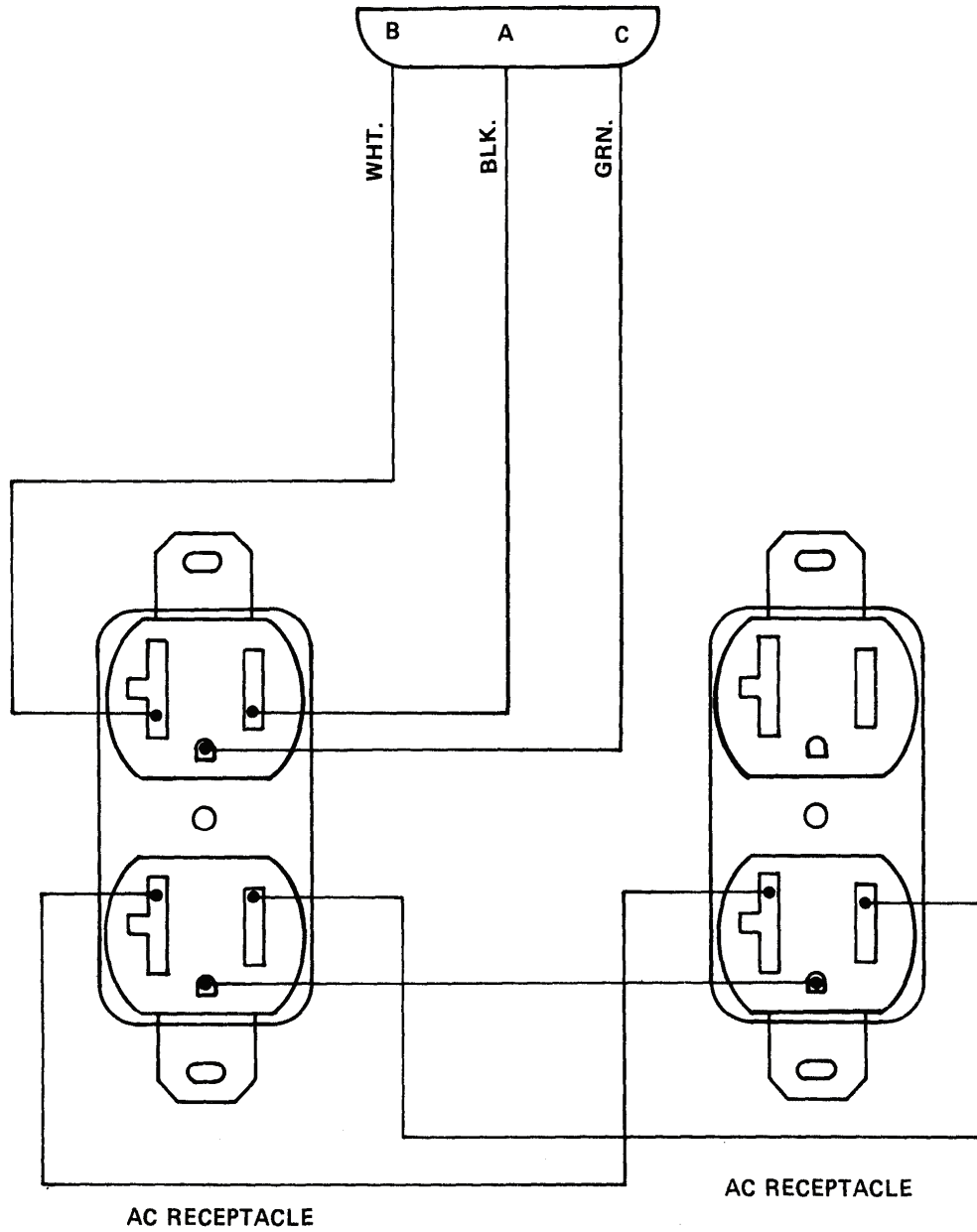

Figure 2. Duplex Receptacle Wiring Diagram

END OF WORK PACKAGE

**FIELD LEVEL MAINTENANCE INSTRUCTIONS
INCANDESCENT UTILITY LIGHT ASSEMBLY (M46 Only)
REPLACE, TEST**

INITIAL SETUP:**Tools**

General Mechanic's Automotive Tool Kit
(Item 1, WP 0035)

Materials/Parts

None

References

None

Equipment Conditions

Power Shut down

REPLACE**WARNING**

High voltage is present in this system. DISE and PDISE support equipment using 120/208 VAC. Do not replace a connector assembly with the power on. Death or serious injury may result.

1. Remove screws (1) securing cable grip (2) and remove cable grip halves.
2. Remove screws (3) securing pin group (4) inside connector body (5).
3. Remove pin group (4) from connector body (5).
4. Loosen screws (6) and remove pin group (4) from cable (7).
5. Remove metal guards by loosening screws (8) securing guard (9) and remove guard.

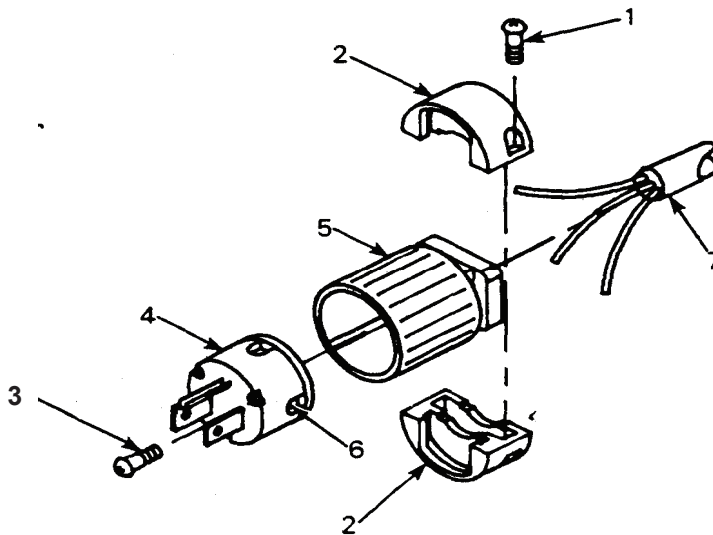

Figure 1. Incandescent Light Assembly (1 of 2)

6. Remove plug (10) and hook assembly (11), if present.

CAUTION

Do not distort bulb socket.

7. Carefully remove bulb sockets (12) from rubber handle (13).
8. Remove knurled nut (14) and switch assembly (15).
9. Tag wires according to Figure 2 and replace defective parts as necessary.

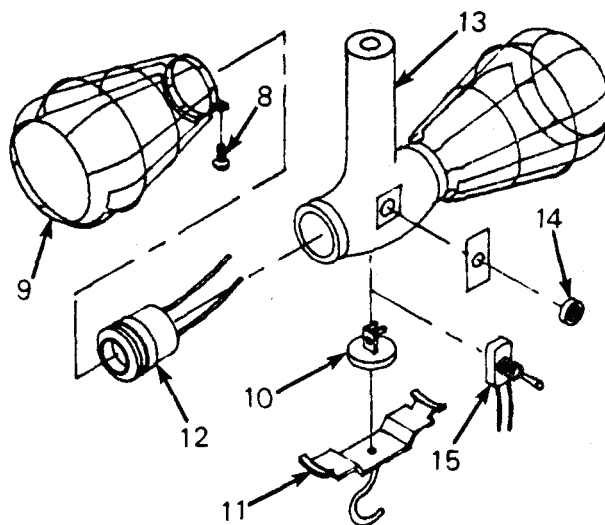

Figure 1. Incandescent Light Assembly (2 of 2)

10. Position switch assembly (15) inside rubber handle (13) and secure with knurled nut (14).
11. Press bulb sockets (12) into rubber handle (13).
12. Press plug (10) and hook assembly (11), if present, into rubber stock.
13. Install guard (9) and secure with screws (8).
14. Install connector body (5) and pin group (4) on cable wires (7) and secure with screws (6).
15. Position pin group (4) inside connector body (5).
16. Install screws (3) and secure pin group (4) to connector body (5).
17. Position grip halves (2) on cable and connector body (5) and secure with screws (1).

TEST

WARNING

High voltage is present in this system. DISE/PDISE supports equipment using 120/208 VAC. Do not attempt continuity check with the power on. Death or serious injury may result.

Refer to following table to perform a continuity test on the incandescent utility light.

Table 1. INCANDESCENT UTILITY LIGHT

NOTE

x indicates continuity

0 indicates no continuity

Standard Plug	Bulb Sockets		
	Center Contact	Sleeve Contact	Ground
Phase Line (Narrow Pin) (Black Wire)	x	0	0
Neutral Line (Wide Pin) (White Wire)	0	x	0
Ground Line (Ground Pin) (Green Wire)	0	0	x

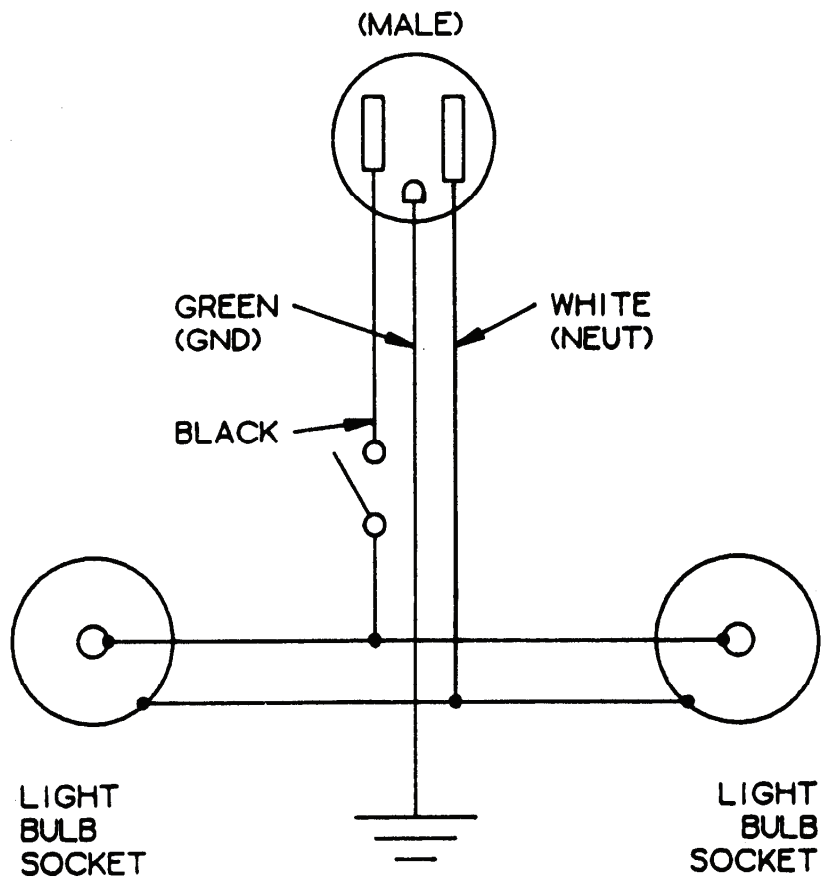

Figure 2. Incandescent Utility Light Assembly Wiring Diagram.

END OF WORK PACKAGE

FIELD LEVEL MAINTENANCE INSTRUCTIONS
36" FLUORESCENT UTILITY LIGHT ASSEMBLY
REPLACE

INITIAL SETUP:**Tools**

General Mechanic's Automotive Tool Kit
(Item 1, WP 0035)

References

None

Equipment Conditions

Power shut down

WARNING

High voltage is present in this System. DISE/PDISE supports equipment using 120/208 VAC. Do not replace a connector assembly with the power on. Death or serious injury may result.

CAUTION

Unplug Light Assembly from system before performing any maintenance.

REPLACE

1. Remove wire/cable tie from smaller end cap located opposite handle. Do not remove handle.
2. Remove strain relief nut and sleeve from strain relief then remove end cap by gently prying off tube with a screwdriver or similar tool. Do not loosen jam nut.
3. Carefully remove shock, using care not to pull on cord. On Model 31-502SK do not remove screen when removing shock.

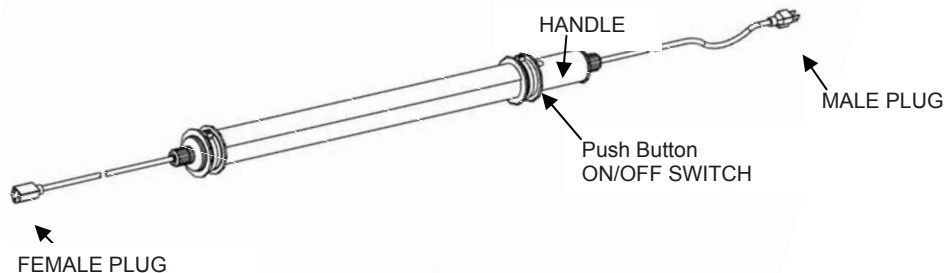

Figure 1. Fluorescent Utility Light Assembly

4. Grasp bulb puller and gently but firmly pull bulb out of socket and removed from outer tub. Take care since bulb is tightly wedged in socket.
5. Remove bulb puller from old bulb and dispose of bulb properly. If old bulb is not broken, there is a vacuum inside and breaking the bulb can be dangerous.
6. Clean inside of outer tube if necessary.
7. Install bulb puller on new bulb as shown. This will assist in removing bulb the next time.
8. Slide new bulb/bulb puller into outer tube and align so pins will intersect with receiver holes in socket. On Model 31- 502SK do not pull on metal braid.
9. Gently push bulb down into socket and seat pins in receiver holes.
10. Plug light in and activate switch. Ensure bulb is seated properly and that it illuminates.
11. Replace shock, using care not to pull on cord or screen.
12. Replace end cap, making ceertain cap is fully seated in groove4 of tube. Secure with a 150-lb. minimum cable/wire tie.

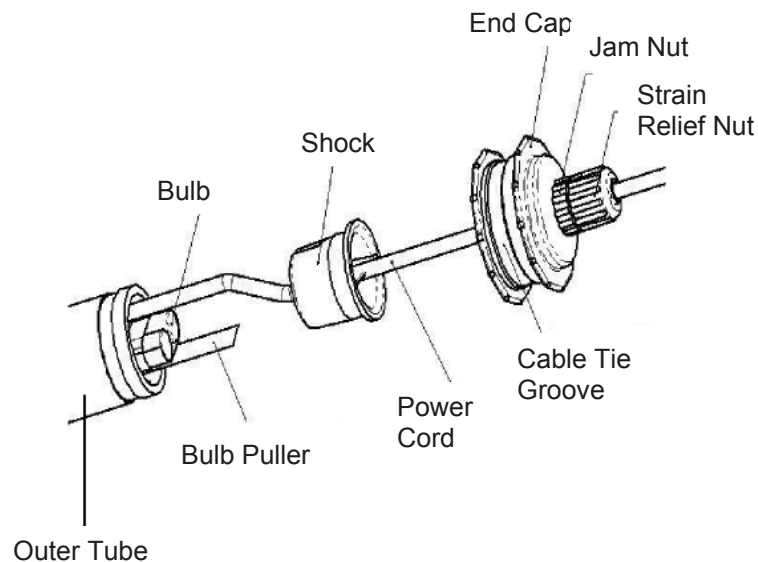

Figure 2. Fluorescent Utility Light Assembly

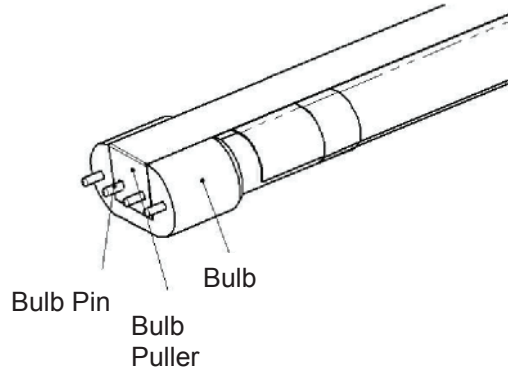

Figure 3. Fluorescent Utility Light Assembly

END OF WORK PACKAGE

**FIELD LEVEL MAINTENANCE INSTRUCTIONS
UNIVERSAL ADAPTER- MOUNTING BOARD AND INPUT CONNECTOR
REPLACE, TEST**

INITIAL SETUP:**Tools**

General Mechanic's Automotive Tool Kit
(Item 1, WP 0035)

Equipment Conditions

Power shut down

Reference

WP 0015

Materials/Parts

None

WARNING

High voltage is present in this system. DISE and PDISE support equipment using 120/208 VAC. Do not replace a connector assembly with the power on. Death or serious injury may result.

CAUTION

Failure to support the universal adapter lid may result in damage to the hinges.

REPLACE

1. Remove lanyard assembly. (WP 0015)
2. Remove bolts (Figure 1, Item 5) securing terminal board (Item 6).
3. Remove terminal board (6) from universal adapter box.
4. Tag wires (7) according to the load terminal connection.
5. Remove nuts (8) and washers (9) and disconnect wires from bottom of load terminals (10).
6. Remove nuts (11), washers (12), and screws (13) securing input connector (14) to box and remove connector.
7. Insert input connector (14) through front of box and secure with nuts (11), washers (12), and screws (13).
8. Connect tagged wires (7) to bottom of load terminals according to Figure 2.
9. Position terminal board (6) inside universal adapter box and secure board with bolts (5).
10. Connect lanyard assembly. (WP 0015)

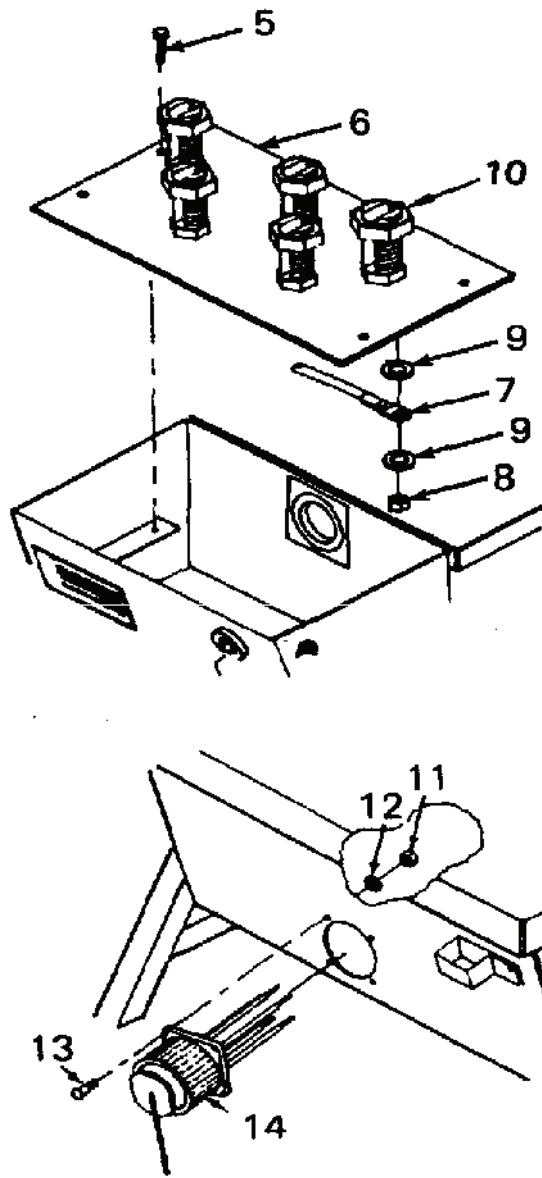

Figure 1. Input Connector and Mounting Board

WARNING

High voltage is present in this system. DISE and PDISE support equipment using 120/208 VAC. Do not attempt continuity check with the power on. Death or serious injury may result.

TEST

Perform continuity test below.

NOTE

X indicates continuity

0 indicates no continuity

Table 1. UNIVERSAL ADAPTER CONTINUITY CHECKS (see Figure 2)

Input Connector	Out Terminals				
	L1	L2	L3	LO	G
J1-A	X	0	0	0	0
J1-B	X	0	0	0	0
J1-C	0	X	0	0	0
J1-N	0	0	X	0	0
J1-G	0	0	0	0	X

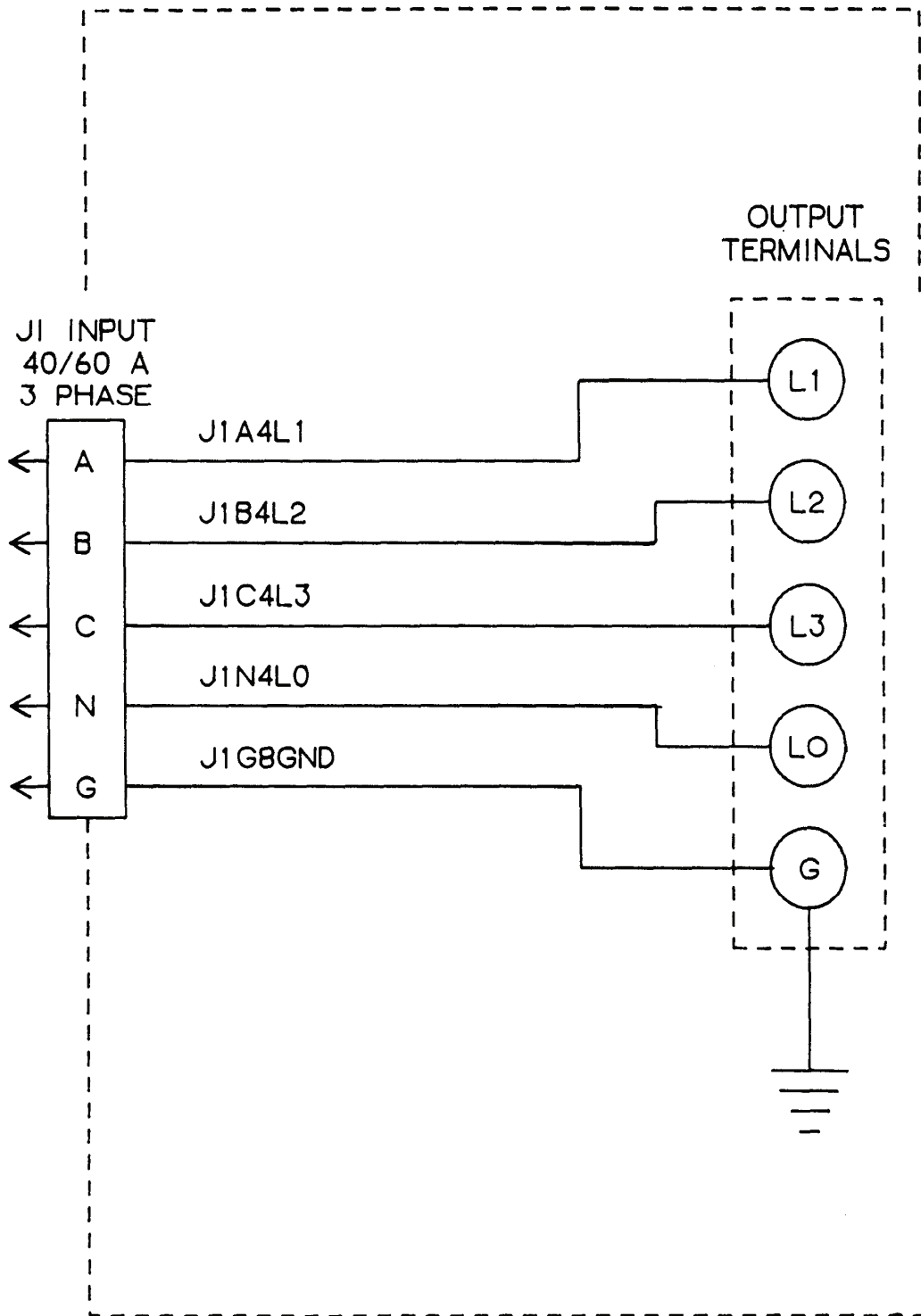

Figure 2. Universal Adapter Wiring Diagram

END OF WORK PACKAGE

FIELD LEVEL MAINTENANCE INSTRUCTIONS
LOAD TERMINAL
REPLACE

INITIAL SETUP:**Tools**

General Mechanic's Automotive Tool Kit
(Item 1, WP 0035)

Personnel Required

One

References

WP 0015

Equipment Conditions

None

WARNING

High voltage is present in this system. DISE and PDISE support equipment using 120/208 VAC. Do not replace a connector assembly with the power on. Death or serious injury may result

REPLACE

1. Remove lanyard assembly. (WP 0015)
2. Remove nuts (Figure 1, Item 1) and washers (Figure 1, Item 2) securing load terminal (Figure 1, Item 3) to terminal board (Figure 1, Item 4).
3. Remove load terminal (3).
4. Insert load terminal (3) through terminal board (4).
5. Secure load terminal (3) to terminal board (4) with nuts (1) and washers (2).
6. Install lanyard assembly (WP 0015).

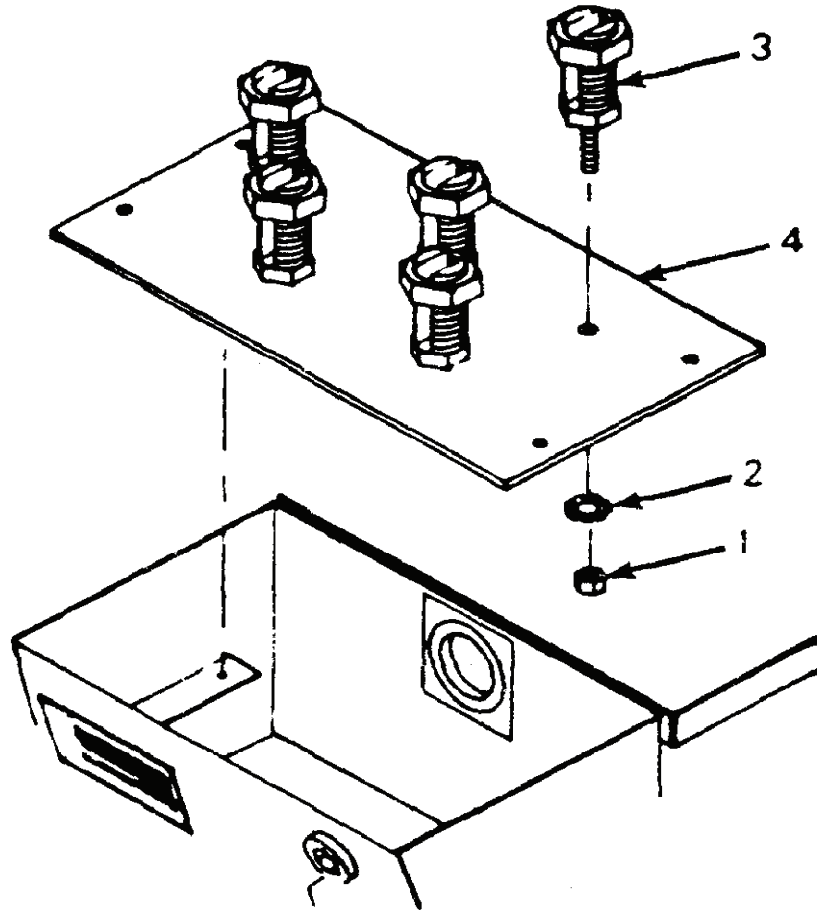

Figure 1. Load Terminal

END OF WORK PACKAGE

**FIELD LEVEL MAINTENANCE INSTRUCTIONS
DISE AND PDISE SYSTEMS
CABLE CONNECTOR REPAIR PROCEDURES**

INITIAL SETUP:**Tools and Special Tools**

General Mechanic's Automotive Tool Kit
(Item 1, WP 0035)
Crimping Tool Kit (Item 14, WP 0035)
Cable Stripper (Item 20, WP 0035)
Pneumatic Crimping Tool (Item 15, WP 0035)

Materials/Parts

Cleaning Lubricant (Item 3, WP 0038)
Tape (Item 10 thru 15, WP 0038)

Equipment Conditions

Power shut down

Reference

WP 0021
WP 0030
WP 0031

Personnel Required

One

REPAIR**NOTE**

- Cable-type connectors mount on cable ends. Wall-type connectors mount on feeder/distribution centers. Go to WP 0030 for repair of feeder/distribution connectors.
- Female connectors use sockets; male connectors use pins. The procedures refer to pins only, but apply to both types of connectors.

The following procedures are for typical connectors and are general repair procedures for any cable connector. You must refer to WP 0031 for applicable insertion, removal, and crimping tools needed. Appearance of actual parts may vary from these illustrations.

Connector Removal

1. Loosen cable gland nut (Figure 1, Item 1) with 10' slip joint pliers.

NOTE

Gland nut has left-hand threads.

2. Compress wire mesh (Figure 1, Item 2) and slide cable, gland nut, and wire mesh approximately 12' up the cable

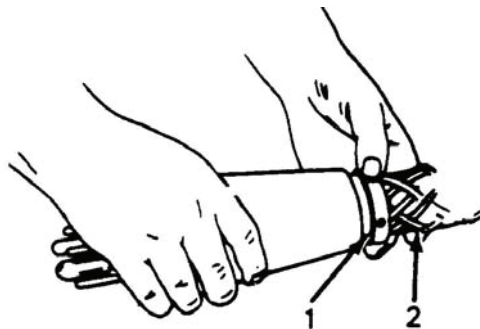

Figure 1. Cable Disassembly (1 of 4)

- Loosen three hex-socket screws (Figure 1, Item 3).

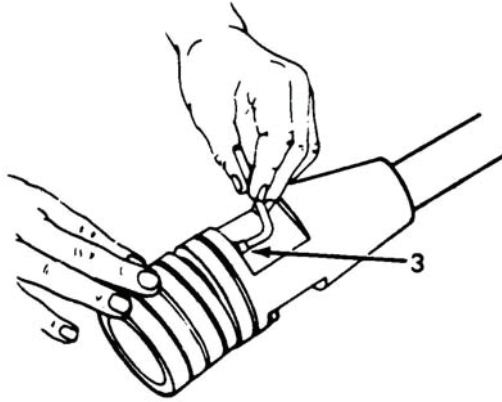

Figure 1. Cable Disassembly (2 of 4)

- Remove connector head (Figure 1, Item 4) from connector body (Figure 1, Item 5).

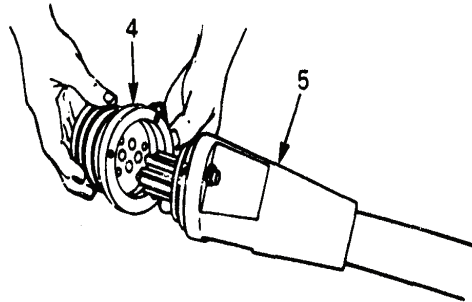

Figure 1. Cable Disassembly (3 of 4)

- Apply lubricant on cable directly behind connector and push cable forward into connector body (5) in order to force support group (Figure 1, Item 6) out.

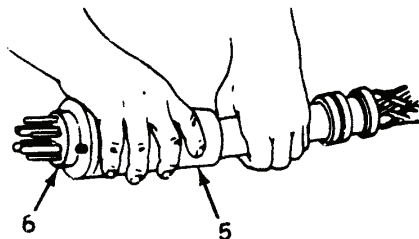

Figure 1. Cable Disassembly (4 of 4)

6. Use proper pin extractor tool (See WP 0031) and remove pins from support group.

NOTE

Ensure to cut wires as close as possible to pins in order to ease connector assembly.
Record the order and direction of connector parts as they are removed.

7. Cut cable wires and remove connector body (Figure 2, Item 1), glands (Figure 2, Item 2, 3) and wire mesh (Figure 2, Item 4) from cable.

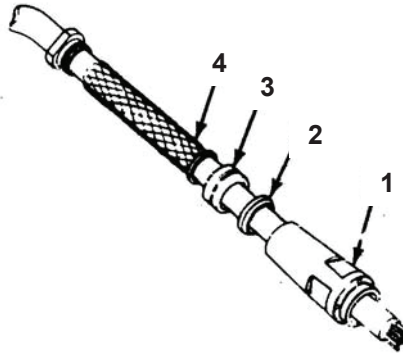

Figure 2. Connector Assembly Layout.

Connector Installation to Cable

CAUTION

When installing both a male and a female connector on a length of bulk cable, the connectors must be installed on particular cable ends so that the tagged wires are matched up to their respective connector plugs. Be advised, colors may not always match up due to multiple manufacturers. Failure to recognize this may cause damage to equipment.

1. Install wire mesh (4), glands (2, 3), and connector body (1).
2. Cut and remove proper length of insulation from outer cable jacket and wires. In order to install electrical connectors to cable ends, you will need to cut and remove the cable jacket and insulation as follows:

CAUTION

The following cut of the outer cable jacket must be made so that each of the eight conductors extends at least $4 \pm 1/16$ inches (102 ± 1.6 mm) from the jacket cut. If a conductor is out of tolerance, the 200-amp connector cannot be assembled.

200-amp, 8 -Pin/Wire, Cables.

- (a). Carefully cut and remove 4 inches of outer cable jacket from end of cable.
- (b). Carefully cut and remove 7/8 inch of conductor insulation from end of each conductor.
- (c). Continue to Step 3.

100-amp, 8-Pin/Wire, Cables.

- (a). Carefully cut and remove 3-1/2 inches (89 mm) of outer cable jacket from end of cable.
- (b). Carefully cut and remove 7/8 inch (22 mm) of conductor insulation from end of each conductor.
- (c). Continue to Step 3.

40/60-amp, 5-Pin/Wire, Cables.

- (a). Carefully cut and remove 3-1/2 inches (89 mm) of outer cable jacket from end of cable.
- (b). Cut off 1/2 inch (13 mm) from phases A, B, C, and neutral conductor (the four large conductors).
- (c). Carefully cut and remove 7/8 inch (22 mm) of conductor insulation from end of each conductor.
- (d). Continue to Step 3.

60-amp, 4-Pin/Wire, Cables.

- (a). Carefully cut and remove 3 inches (76 mm) of outer cable jacket from end of cable.
- (b). Carefully cut and remove 7/8 inch (22 mm) of conductor insulation from end of each conductor.
- (c). Continue to Step 3.

20-amp, 3-Pin/Wire, Cables.

- (a). Carefully cut and remove 1/2 inch (13 mm) of outer cable jacket from end of cable.
- (b). Carefully cut and remove 3/8 inch (10 mm) of conductor insulation from end of each conductor.
- (c). Continue to Step 3.

3. Use a multi-meter to determine correct pin-to-wire installation.
4. Tag wires according to their designation.

NOTE

The long pin attaches to the neutral wire of the male connector.

5. Remove pneumatic crimper die retaining ring (Figure 3, Item 1) and crimper die.

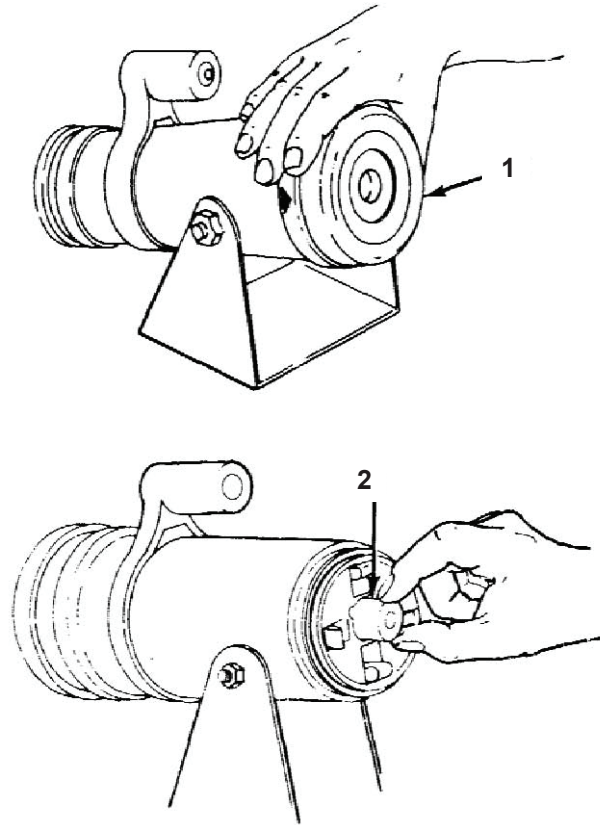

Figure 3. Pneumatic Crimper

6. Refer to WP 0031 and select the proper pin/socket locator (Figure 3, Item 2). Place locator into crimper so notches in crimper and locator align.

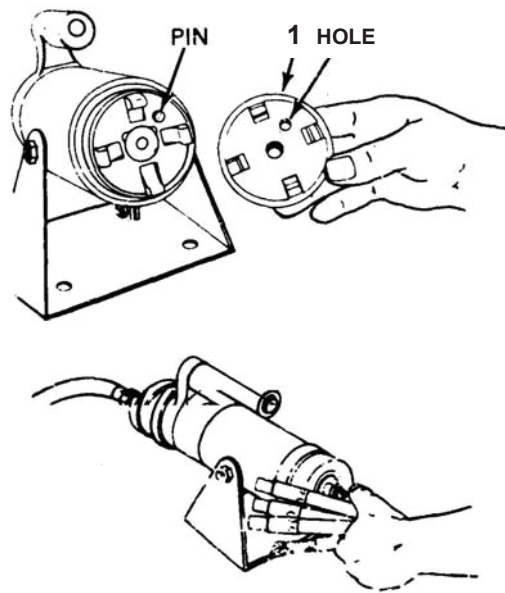

Figure 4. Crimping Die

7. Use appropriate crimping die (See WP 0031) (Figure 4, Item 1) and install onto crimper so pin and hole align. Install retaining ring.
8. Slide pins onto cable wire and crimp in place.

CONNECTOR ASSEMBLY

WARNING

High voltage is present in this system. DISE/PDISE supports equipment using 120/208 VAC. Do not rely on the color of the wire insulation for phase color-coding. The insulation on the wires inside the cable jacket may vary, depending on the supplier. Wires will be color-coded to designate the phases. Perform a continuity test to verify correct phase designation in accordance with identified color. Failure to recognize this may result in death or injury to personnel and/or damage to equipment.

1. Determine correct pin letter and wire color codes below.

Keyway and Pin Positioning

The key and pins of the plug connectors (male) and the keyways and sockets of the receptacle connectors (female) must be properly positioned to ensure a correct phase match. Figures 5-8 indicate the proper key positions when assembling a connector.

Wire Color Codes

- (a). **Service/feeder and pigtail cable wires** are tagged with color-coded tape and pin match (See Fig. 5 thru 7) as follows:
 - Phase line A (L1) -black wire connects to pin/socket marked A.
 - Phase line B (L2) - red wire connects to pin/socket marked B.

- Phase line C (L3) - blue wire connects to pin/socket marked C.
- Neutral line (LO) - white wire connects to pin/socket marked N

NOTE

If there are one or more ground wires, connect to pins marked G1, G2, G3, or G4 as applicable.

- Ground lines – green (or bare) wires connect to pins/sockets marked G.

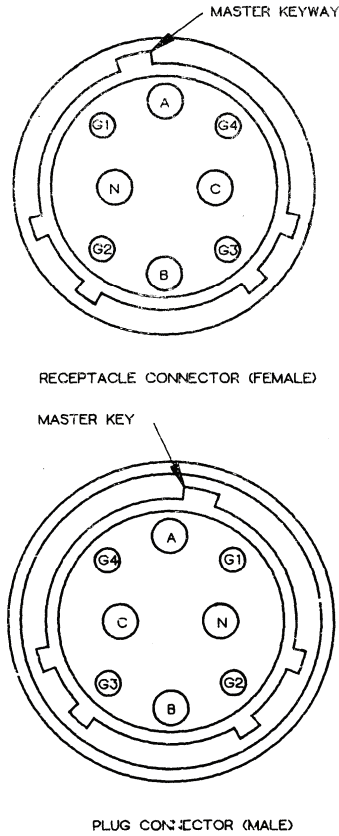

Figure 5. 200 and 100-amp, 8-wire Connector Face/ Key Positioning

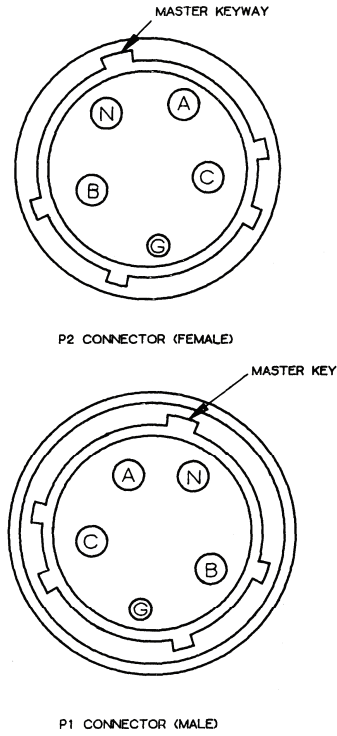

Figure 6. 40/60-amp, 5-wire Connector Face/ Key Positioning.

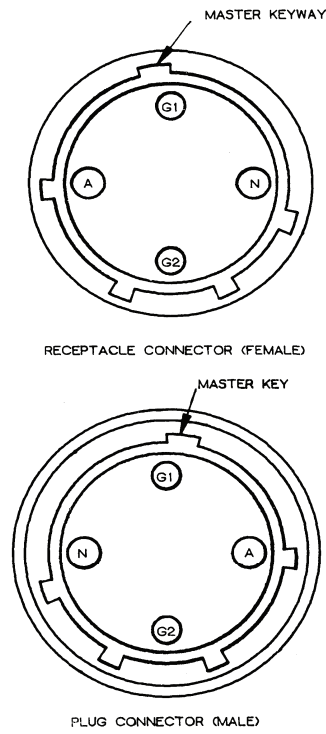

Figure 7. 60-amp, 4-wire Connector Face/ Key Positioning.

(b). DISE and PDISE **extension and branch circuit cable wires** are color coded and pins matched (See Figure 8) as follows:

- Phase line – black wire connects to pin/socket marked A.
- Neutral line – white wire connects to pin/socket marked B.
- Ground line – green wire connects to pin/socket marked C.

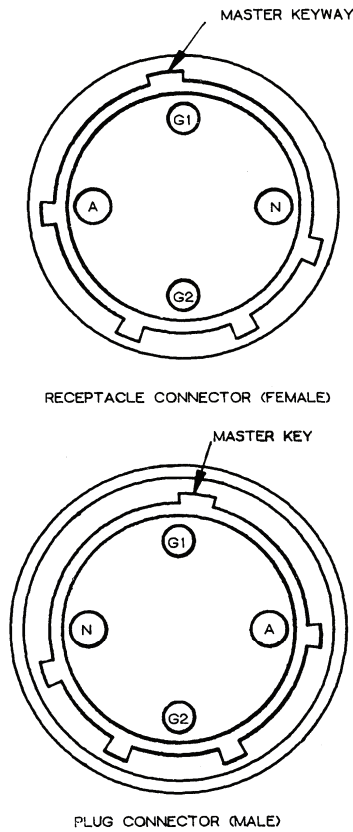

Figure 8. 20-amp, 3-wire Connector Face/ Key Positioning.

NOTE

Use cleaning lubricant to aid installation of pins into support group.

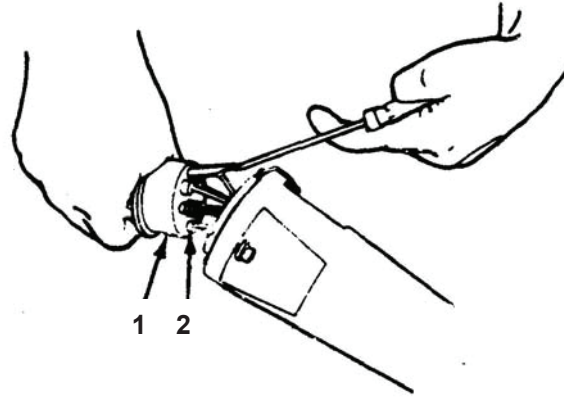

Figure 9. Installing Pin with Insertion Tool

3. Use proper insertion tool/s (WP 0031) and insert pins (Figure 9, Item 2) into support group (Figure 9, Item 1).
4. Determine correct pin-to-key positioning on new connector as stated above and shown in Figures 5 through 8.

NOTE

See the following alternate method for inserting pins collectively into the support group for the 100-amp, 8-pin; 40/60-amp, 5-pin; and 60-amp, 4-pin cable connectors. If you are not working these cables, continue to Step 5.

- a. Start the A-pin into support group (6).
- b. Start the N-pin into support group (6).
- c. Slide support group (6) halfway over the A- and N-pins.
- d. Start the B-pin into support group (6).
- e. Start the C-pin into support group (6).
- f. Slide support group (6) as far possible over all the pins.
- g. Rock support group (6) toward the A-pin until it locks into position.
- h. Rock support group (6) toward the N-pin until it locks into position.
- i. Rock support group (6) toward the N-pin until it locks into position.
- j. Grasp the C-pin wire and push the wire toward support group (6) while rocking the support group toward the C-pin until it locks into position.
- k. Grasp the B-pin wire and push the wire toward support group (6) while rocking the support group toward the B-pin until it locks into position.

- l. Select a G-pin wire nearest to its support group (6) hole. Use long-nosed pliers to grasp the pin and insert the pin into its hole and lock position.
 - m. Insert remaining G-pins into support group (6) as described above.
- 5. Slide connector body (Figure 1, Item 5) down cable and position support group (Figure 1, Item 6) and connector body together.
- 6. Install connector head (Figure 1, Item 4) on connector body (Figure 1, Item 5).
- 7. Install hex-socket screws (Figure 1, Item 3).

NOTE

Cable gland nut has left-hand threads.

- 8. Slide glands (Figure 2, Items 2 & 3), wire mesh, (Figure 2, Item 4), and cable gland nut (Figure 1, Item 1) into connector body (Figure 1, Item 5) and tighten nut.
- 9. Use a multi-meter and perform a continuity test to verify correct assembly and pin seating. (See WP 0021 for cable continuity readings)

END OF WORK PACKAGE

**FIELD LEVEL MAINTENANCE INSTRUCTIONS
DISE AND PDISE SYSTEMS
FEEDER/DISTRIBUTION CONNECTOR REPAIR PROCEDURES**

INITIAL SETUP:**Tools and Special Tools**

General Mechanic's Automotive Tool Kit
(Item 1, WP 0035)
Crimping Tool Kit (Item 14, WP 0035)
Cable Stripper (Item 20, WP 0035)

Materials/Parts

Tape (Item 10 thru 15, WP 0038)

Equipment Conditions

Power shut down

Reference

WP 0029

WP 0031

WP 0038

Personnel Required

One

REPAIR**NOTE**

- Cable-type connectors mount on cable ends. Wall-type connectors mount on feeder/distribution centers. Go to WP 0029 for repair of cable connectors.
- Female connectors use sockets

Connector Disassembly**NOTE**

Nut has left-hand threads.

1. Remove nut (Figure 1, Item 1).

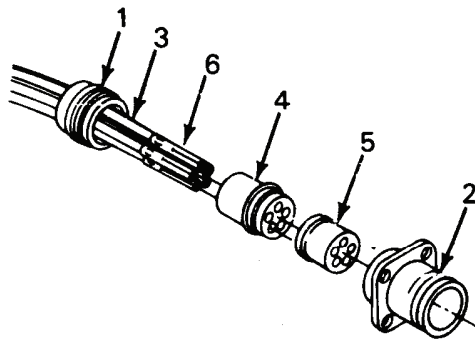

Figure 1. Connector Layout

2. Remove wires (3), rear support group (4), and forward support group (5).
3. Remove forward support group (5) from pins (6).
4. Use removal tool (See WP 0031) and remove pins (6) from rear support group (4).
5. Replace defective parts as per WP 0038.

Connector Assembly

1. Install wires and pins (6) into rear support group (4).

NOTE

Pins should lock into place when seated properly.

2. Position forward support group (5) over pins.

NOTE

- Ensure position markings on rear and forward support groups match.
 - Forward support group (5) and connector are keyed to fit together.
3. Refer to WP 0031 for proper connector-face key positioning and install rear support group (4) and forward support group (5) into connector (2).

NOTE

Nut has left-hand threads.

4. Install nut (1) on connector (2).

END OF WORK PACKAGE

**FIELD LEVEL MAINTENANCE INSTRUCTIONS
DISE AND PDISE SYSTEMS
GENERAL WIRING MAINTENANCE / WIRING DIAGRAMS**

GENERAL

This section provides procedures to be followed for the repair and reference to fabrication of DISE and PDISE cable assemblies to the extent authorized at the Field maintenance level described in the Maintenance Allocation Chart (MAC). Use the following information listed in this WP to aid in maintenance corresponding to WP 0029 and WP 0030.

DISE and PDISE cables are designed for use in moist climatic conditions; cable splices are unauthorized. Cable assembly repair is limited to shortening the cable by cutting off the damaged portion and reattaching the connector.

Wiring diagrams are provided for general repair methods consisting of replacing wire leads, cables, harnesses, terminals, connectors, etc., rather than splicing wires, bending ends to form terminals, and other make shift procedures. Make shift repair procedures may be appropriate for emergency field repairs, but should be properly repaired as soon as possible.

Determine the serviceability of an item by comparing its physical, mechanical, and/or electrical characteristics with established standards through examination. MOS 52D, Power Generator equipment repairer, is authorized to perform all Field Level maintenance on DISE/PDISE equipment.

COMMON TOOLS AND EQUIPMENT

For authorized common tools and equipment refer to the Modified Table of Organization and Equipment (MTOE) applicable to your field.

REPAIR PARTS SPECIAL TOOLS, TEST AND SUPPORT EQUIPMENT

Refer to WP 0034, Maintenance Allocation Chart (MAC); TM 9-6150-226- 23P, Repair Parts and Special Tools List; to support equipment for Field Level maintenance.

GENERAL MAINTENANCE PROCEDURES**WARNING**

High voltage is present in this system. DISE and PDISE support equipment using 120/208 VAC. Do not rely on the color of the wire insulation for phase color-coding. The insulation on the wires inside the cable jacket may vary, depending on the supplier. Wires will NOT always be color coded to designate the phases. Perform a continuity test to verify correct phase designation in accordance with identified color and/or pin designation

CAUTION

When installing both a male and a female connector on a length of bulk cable, the connectors must be installed on particular cable ends so that the tagged wires are matched up to their respective connector plugs. Be advised, colors may not always match up due to multiple manufacturers. Failure to recognize this may cause damage to equipment.

Insulating Joints.

The preferred method of insulating bare electrical joints is by using insulation sleeving. To apply, slide a piece of insulation sleeving over the wire lead before making the joint. Make the joint then slide the insulation sleeving over the joint and shrink in place with heat gun.

Crimping Terminals.

DISE/PDISE may or may not require the use of terminals. To install a terminal, strip 1/4-1/2 inch (0.6-1.3 cm) of insulation from the end of the wire lead. Insert bare wire lead end into the shank of the terminal. Crimp the shank securely onto the wire lead.

WARNING

Solder and flux contain materials which are hazardous to health. Avoid breathing vapors or fumes from soldering operations. Perform operations only in well ventilated areas. Wash hands with soap and water after handling solder and flux. Wear thermal gloves and protective goggles or face shield to protect against burns.

Soldering Connections.

Wire connections must be made mechanically sound before they are soldered; solder alone does not provide sufficient strength to prevent breakage. Joining surfaces of connections to be soldered must be clean and bright. Flux should be brushed onto the joint before soldering. Wires should always be heated with a soldering iron to the point at which the solder will melt completely when touched to joint and flow into all parts of the joint. Excessive build up of solder on the joint should be avoided or removed.

Splicing Wire.

Splicing is the last means necessary to repair a broken or cut wire. To repair broken or cut wires that are otherwise sound, the mating ends can be stripped and spliced by using a crimped splice or by wrapping the stripped wire lead ends onto themselves then soldering, followed by proper insulating.

Connector Crimping Tools

The cable and wall mount connectors have pins (male) or sockets (female) that attach to the wires with a four-indent crimp. Table 1 identifies which tool to crimp each type and size of connector. Table 2 lists the various insertion, removal, locator, and crimp tools spoken of in WP's 0029 and 0030 repair actions.

Feeder/Distribution Center Connectors (Wall-Mount Type)

To determine the correct wire length, correct stripping of wire, and correct selection of pins/sockets, refer to Table 3 or 4. These tables list the connector by type of center and connector position on the center. The table then directs you to the appropriate figure in for information necessary to repair and/or fabricate the connector and/or cable.

NOTE

Cable-type connectors mount on cable ends. Wall-type connectors mount on the feeder/distribution centers Use needle-nose pliers to install pins or sockets which do not have a special installation tool listed.

Table 1. Wall/Cable Connector Tool Selection

Connector Group/Type	Pin/Socket Size	(Refer to Table 2) Item No.			
		Removal Tool	Install Tool	Locate Tool	Crimp Tool
200-A, 8-wire connectors					
Cable-type, large pin/socket	4/0	1	-	11a	11b
Cable-type, small pin/socket	4	3	5	11c	11d
Wall-type, large pin/socket	4/0	1	-	11a	11b
Wall-type, small pin/socket	4	3	5	11c	11d
100-A, 8-wire connectors					
Cable-type, large pin/socket	0	2	-	11e	11f
Cable-type, small pin/socket	6	4	-	11g	11h
Wall-type, large pin/socket	0	2	-	11e	11f
Wall-type, small pin/socket	6	4	-	11g	11h
40/60-A, 5-wire connectors					
Cable-type, large pin/socket	4	3	5	11c	11d
Cable-type, small pin/socket	6	4	-	11g	11h
Wall-type, large pin/socket	4	3	5	11c	11d
Wall-type, small pin/socket	6	4	-	11g	11h
60-A, 4-wire connectors					
Cable-type, large pin/socket	4	3	5	11c	11d
Cable-type, small pin/socket	6	4	-	11g	11h
Wall-type, large pin/socket	4	3	5	11c	11d
Wall-type, small pin/socket	6	4	-	11g	11h
20-A, 3-wire connectors					
All types	12	6, 9, 10	7	-	8

Table 2. CRIMP TOOLS

Item No.	Nomenclature	Size	Part Numbers
1	Removal tool, pin/socket	4/0	M81969/27-01
2	Removal tool, pin/socket	1/0	M8126/27-03
3	Removal tool, pin/socket	4	M8126/27-05
4	Removal tool, pin/socket	6	M81269/27-06
5	Installer tool, pin/socket	4	M81269/17-07
6	Removal tool, pin/socket	12	M81269/8-10
7	Installer tool, pin/socket	12	M81269/8-09
8	Crimp tool, pin/socket	12	WT111M
9	Tool stripper cable		45-156
10	Tool stripper wire	12	WT2000
10a	Tool stripper cable		45-157

Table 2. CRIMP TOOLS (Cont)

Item No.	Nomenclature	Size	Part Numbers
11	Crimp tool system, pneumatic	-	400-1-200-5KL
11a	Locator, pin/ Socket	4/0	4297-5 M22520/23-16
11b	Crimping die, pin/ socket	4/0	414DA-40N-1 M22520/23-07
11c	Locator, pin/ Socket	4	4297-5 M22520/23-12
11d	Crimping die, pin/ socket	4	414DA-4N M22520/23-04
11e	Locator, pin/ Socket	1/0	4297-3 M22520/23-13
11f	Crimping die, pin/ socket	1/0	414DA-0N M22520/23-05
11g	Locator, pin/ socket	6	4297-6 M22520/23-10
11h	Crimping die, pin/socket	6	414DA-6N M22520/23-03

Table 3. DISE Feeder/Distribution Center Connector Repair/Fabrication Reference

M200 (DISE) Feeder Center Connectors

<u>Connector #</u>	<u>Rating</u>	<u>See App F Figure</u>
J1	200 amp Input Connector	F5
J4	100 amp Output Connector	F7
J5	100 amp Output Connector	F7
J6	20 amp Output Connector	F13
J7	60 amp Output Connector	F9
J8	60 amp Output Connector	F9
J9	60 amp Output Connector	F9
J10	60 amp Output Connector	F9
J11	100 amp Output Connector	F7

M100 (DISE) Feeder Center Connectors

J1	100 amp Output Connector	F-6
J2	100 amp Output Connector	F-7
J3	60 amp Output Connector	F-9
J4	40 amp Output Connector	F-9
J5	40 amp Output Connector	F-9
J6	60 amp Output Connector	F-9
J7	20 amp Output Connector	F-14
J8	20 amp Output Connector	F-13

M40 (DISE) Distribution Center Connectors

J1	40 amp Input Connector	F-8
J2	40 amp Output Connector	F-9
J3	20 amp Output Connector	F-12
J4	20 amp Output Connector	F-12
J5	20 amp Output Connector	F-12
J6	20 amp Output Connector	F-12
J7	20 amp Output Connector	F-12
J8	20 amp Output Connector	F-12
J9	20 amp Output Connector	F-12
J10	20 amp Output Connector	F-12
J11	20 amp Output Connector	F-12
J12	20 amp Output Connector	F-12
J13	20 amp Output Connector	F-12
J14	20 amp Output Connector	F-12

Table 3. DISE Feeder/Distribution Center Connector Repair/Fabrication Reference (Cont.)**M60 (DISE) Distribution Center Connectors**

<u>Connector #</u>	<u>Rating</u>	<u>See App F Figure</u>
J1	60 amp Input Connector	F-10
J2	60 amp Output Connector	F-11
J3	20 amp Output Connector	F-12
J4	20 amp Output Connector	F-12
J5	20 amp Output Connector	F-12
J6	20 amp Output Connector	F-12
J7	20 amp Output Connector	F-12
J8	20 amp Output Connector	F-12

Table 4. PDISE Feeder/Distribution Center Connector Repair/Fabrication Reference**M200 (PDISE) Feeder Center Connectors**

<u>Connector #</u>	<u>Rating</u>	<u>See App F Figure</u>
J1	200 amp Input Connector	F26
J4	100 amp Output Connector	F28
J5	100 amp Output Connector	F28
J6	20 amp Output Connector	F34
J7	60 amp Output Connector	F30
J8	60 amp Output Connector	F30
J9	60 amp Output Connector	F30
J10	60 amp Output Connector	F30
J11	100 amp Output Connector	F28

M100 (PDISE) Feeder Center Connectors

J1	100 amp Output Connector	F-27
J2	100 amp Output Connector	F-28
J3	60 amp Output Connector	F-30
J4	40 amp Output Connector	F-30
J5	40 amp Output Connector	F-30
J6	60 amp Output Connector	F-30
J7	20 amp Output Connector	F-35
J8	20 amp Output Connector	F-34

Table 4. PDISE Feeder/Distribution Center Connector Repair/Fabrication Reference (Cont)**M40 (PDISE) Distribution Center Connectors**

<u>Connector #</u>	<u>Rating</u>	<u>See App F Figure</u>
J1	40 amp Input Connector	F-29
J2	40 amp Output Connector	F-30
J3	20 amp Output Connector	F-33
J4	20 amp Output Connector	F-33
J5	20 amp Output Connector	F-33
J6	20 amp Output Connector	F-33
J7	20 amp Output Connector	F-33
J8	20 amp Output Connector	F-33
J9	20 amp Output Connector	F-33
J10	20 amp Output Connector	F-33
J11	20 amp Output Connector	F-33
J12	20 amp Output Connector	F-33
J13	20 amp Output Connector	F-33
J14	20 amp Output Connector	F-33

M60 (DISE) Distribution Center Connectors

J1	60 amp Input Connector	F-31
J2	60 amp Output Connector	F-32
J3	20 amp Output Connector	F-33
J4	20 amp Output Connector	F-33
J5	20 amp Output Connector	F-33
J6	20 amp Output Connector	F-33
J7	20 amp Output Connector	F-33
J8	20 amp Output Connector	F-33

WIRING DIAGRAMS**NOTE**

The following wiring diagrams are representations of data plates found on the inside of the feeder/distribution centers. Individual auxiliary components wiring diagrams are found in their respective Work Packages.

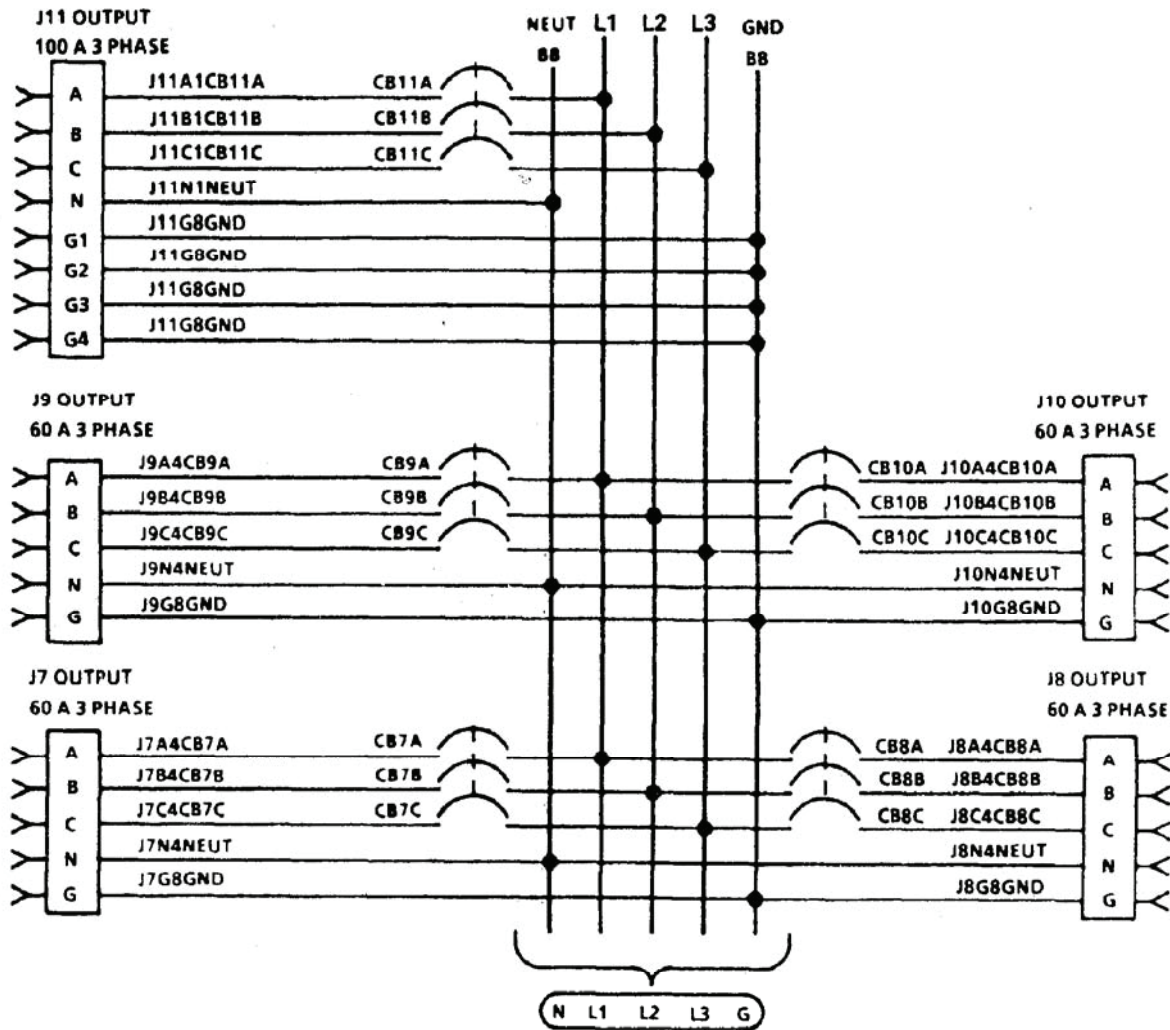

Figure 1. M200 (DISE) Feeder Center Wiring Diagram. (Sheet 1 of 2)

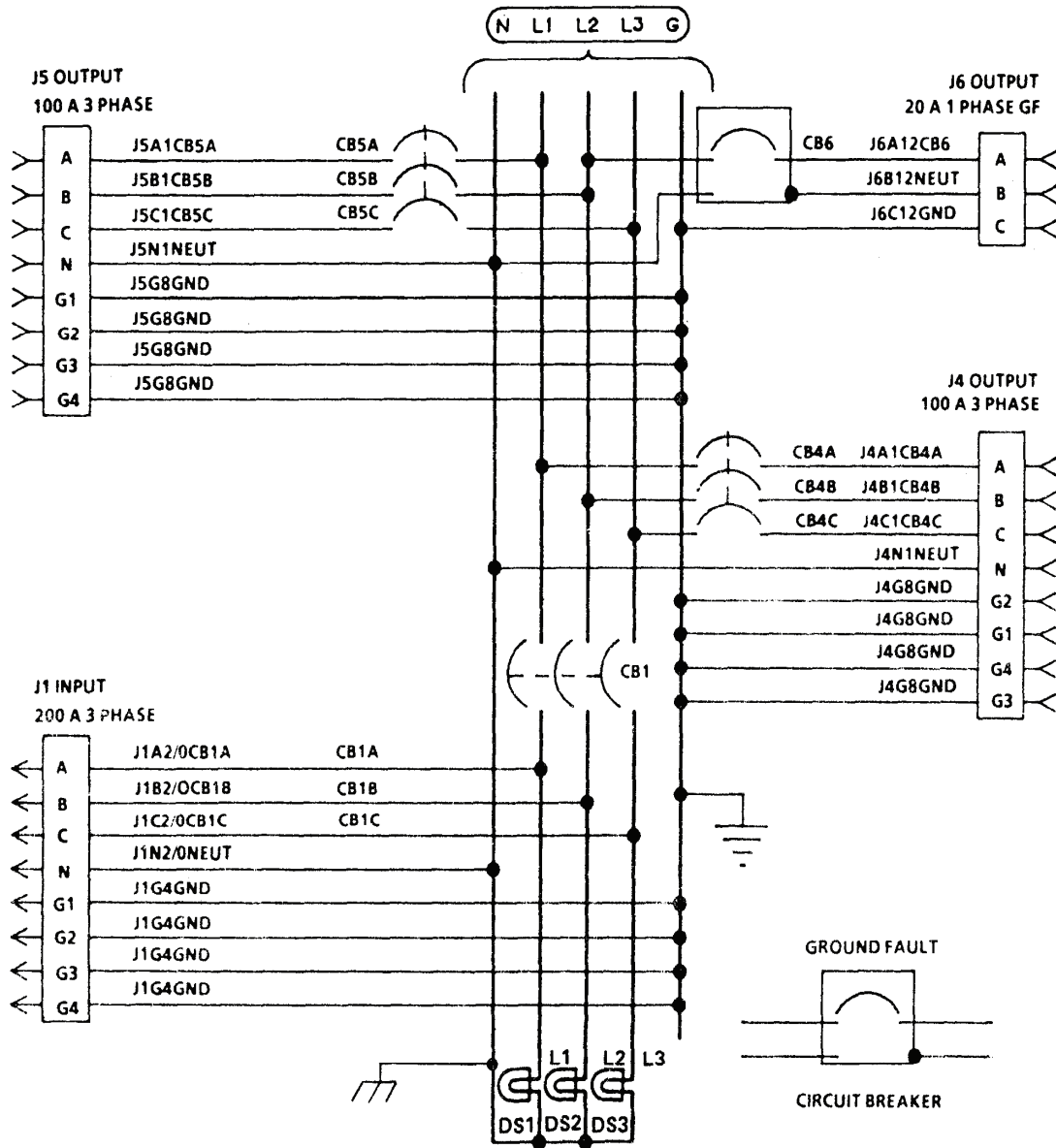

Figure 1. M200 (DISE) Feeder Center Wiring Diagram. (Sheet 2 of 2)

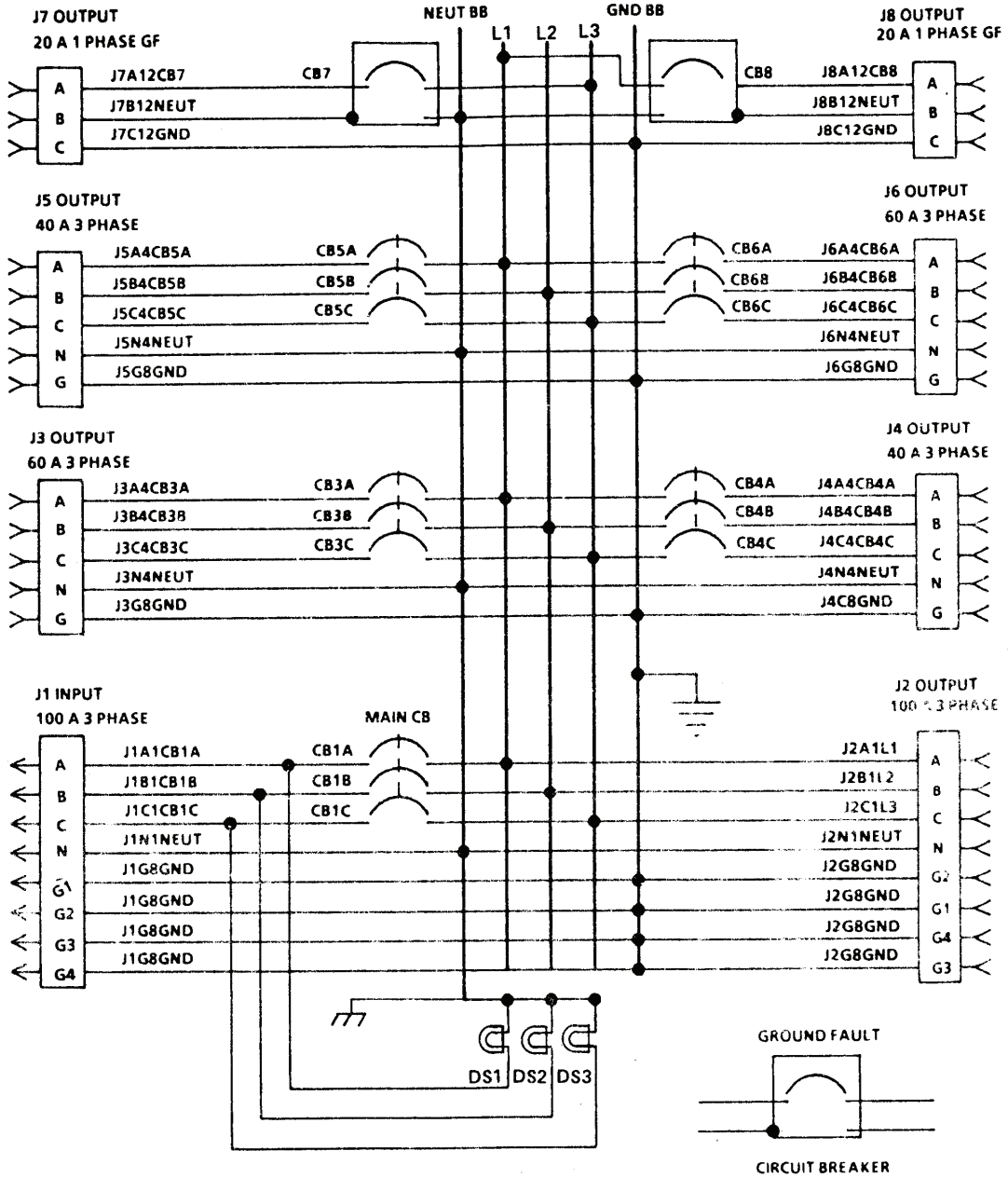

Figure 2. M100 (DISE) Feeder Center Wiring Diagram

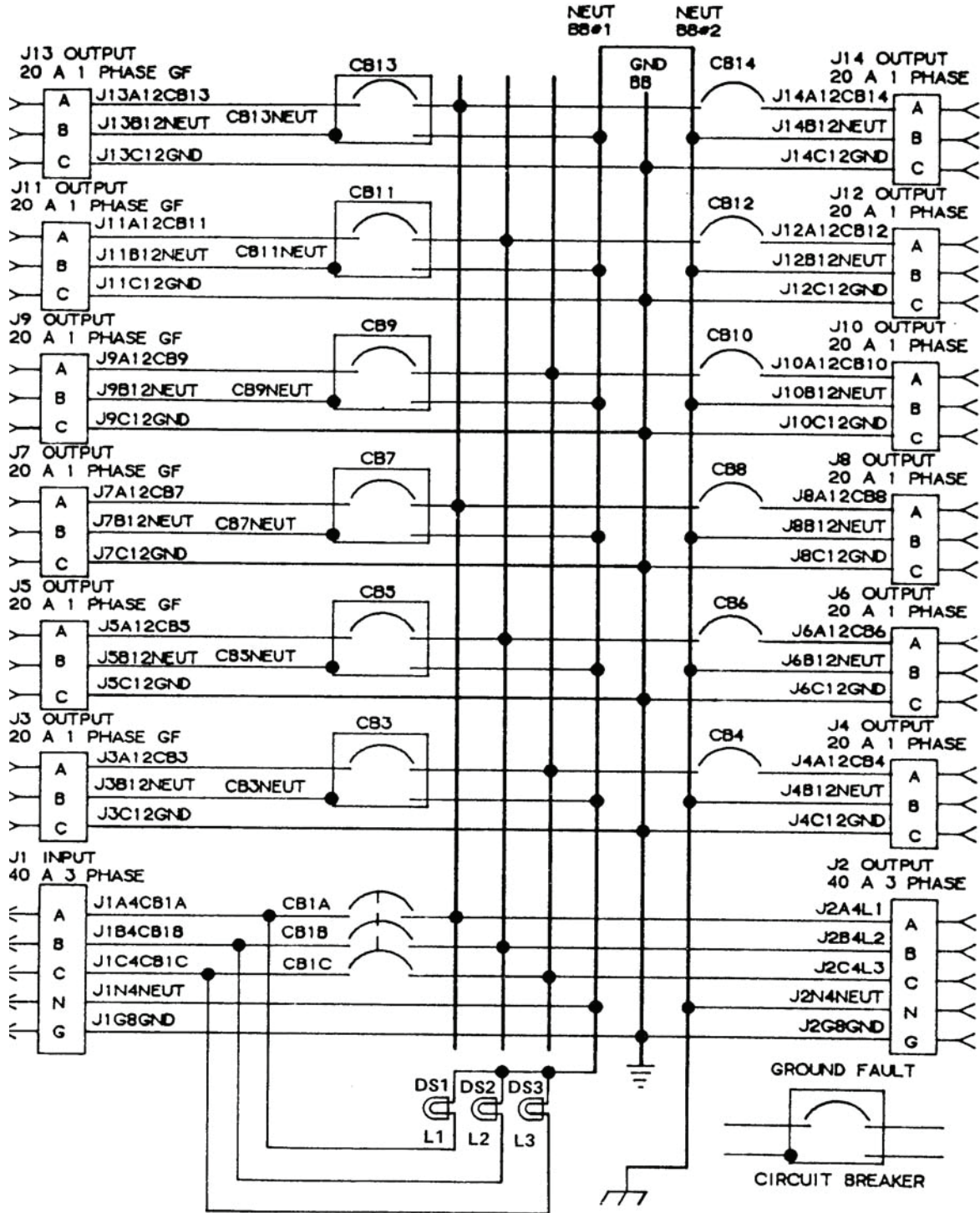

Figure 3. M40 (DISE) Distribution Center Wiring Diagram.

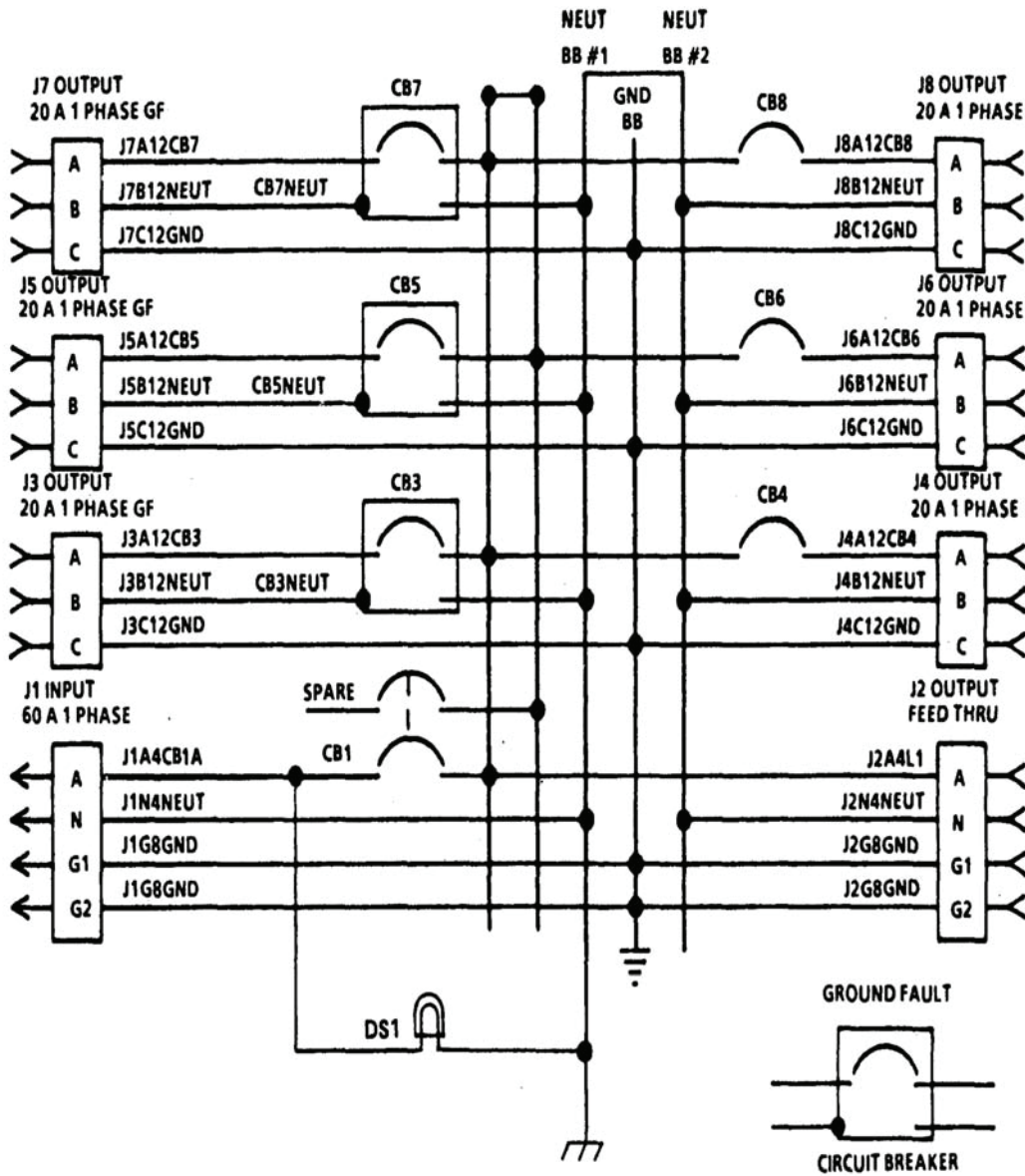

Figure 4. M60 (DISE) Distribution Center Wiring Diagram

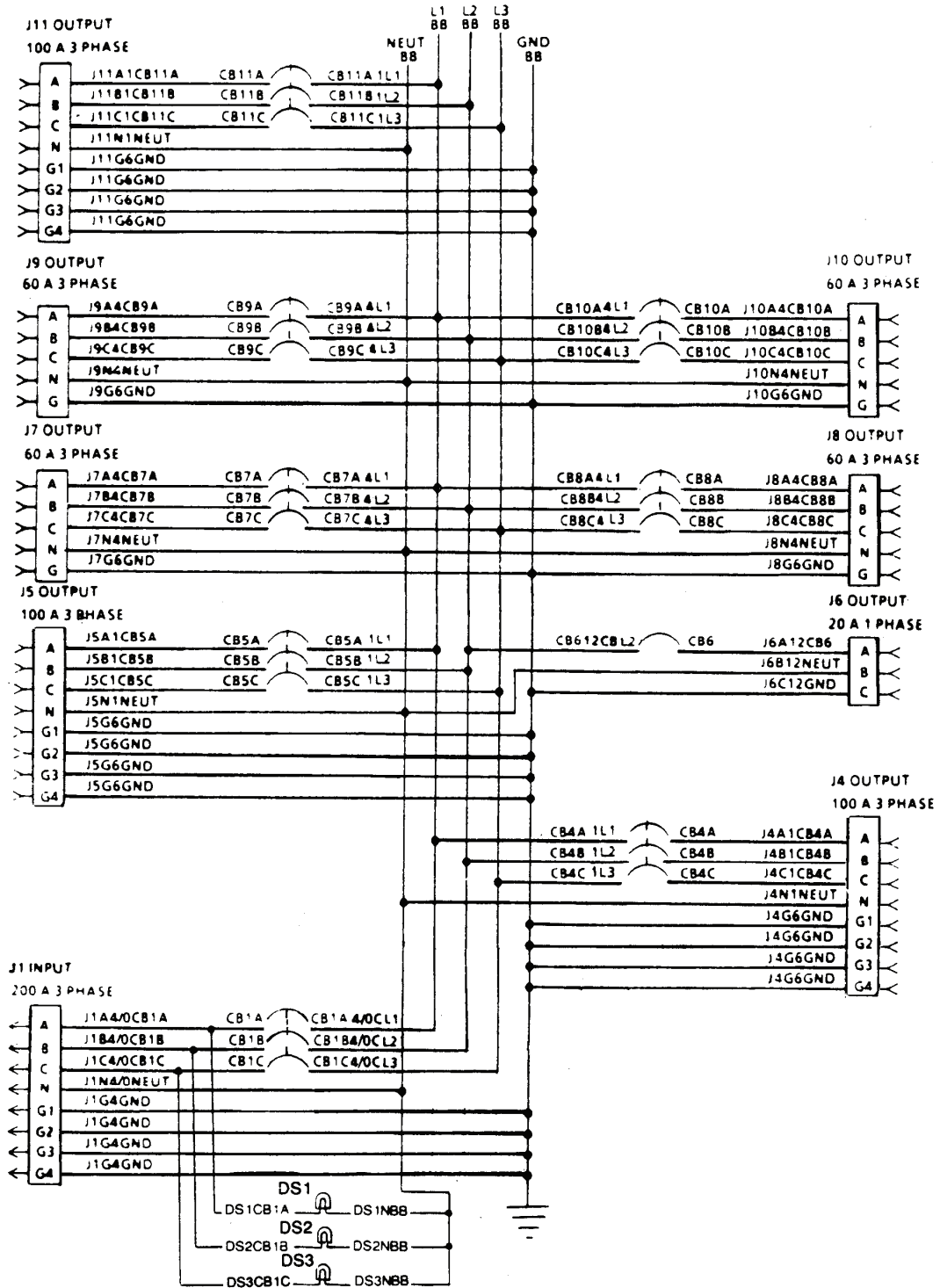

Figure 5. M200 A/P (PDISE) Feeder Center Wiring Diagram.

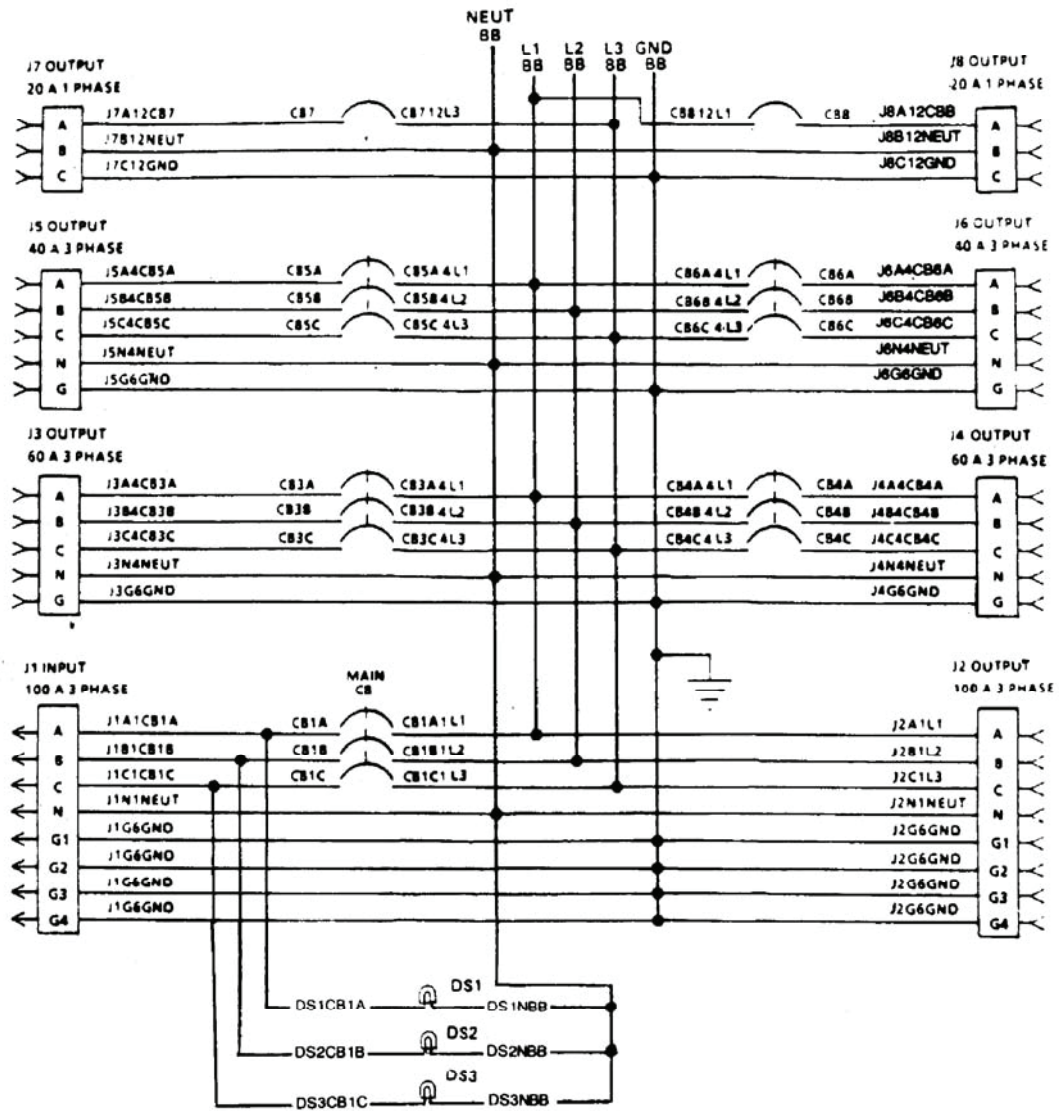

Figure 6. M100 A/P (PDISE) Feeder Center Wiring Diagram.

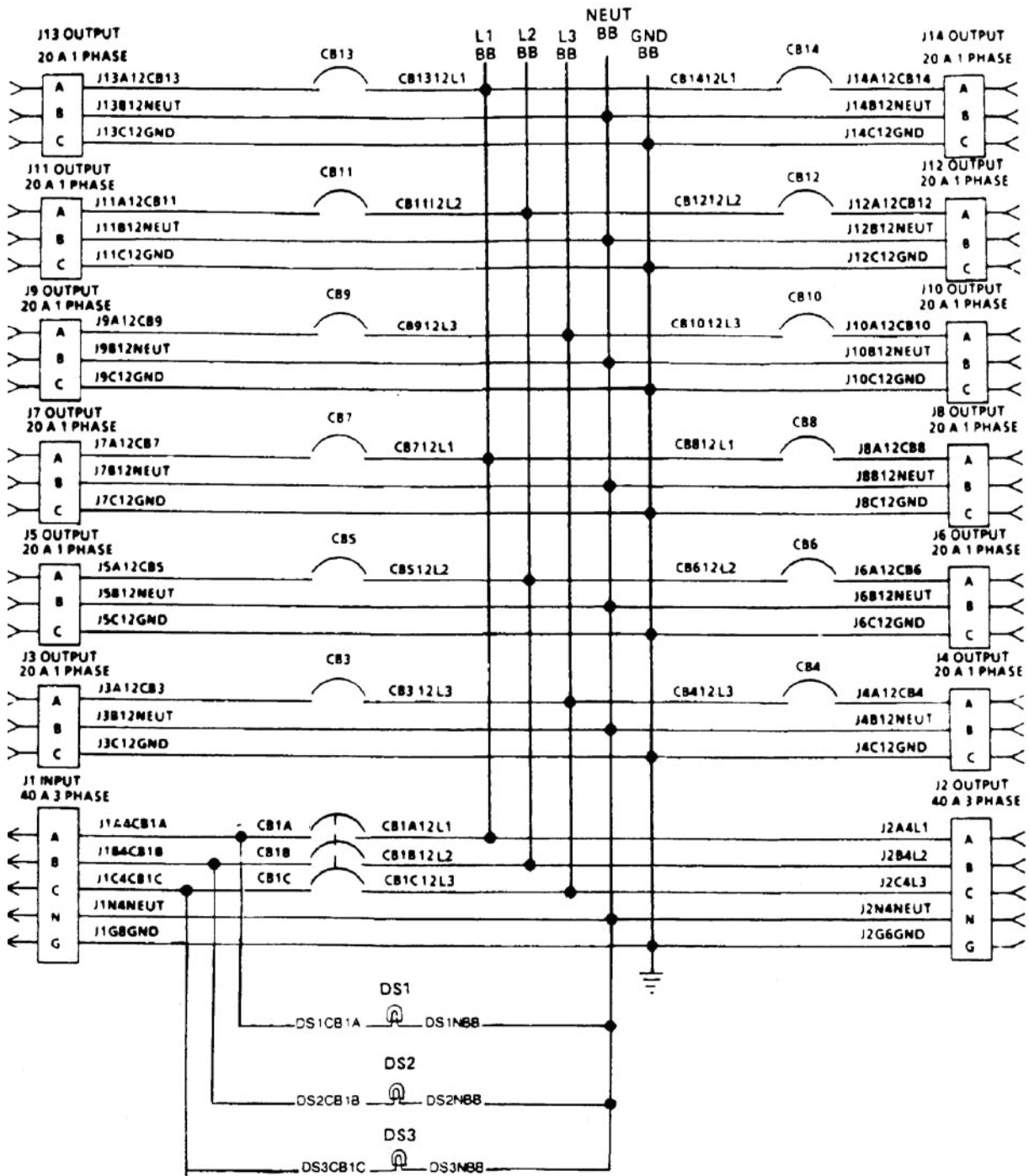

Figure 7. M40 A/P (PDISE) Distribution Center Wiring Diagram.

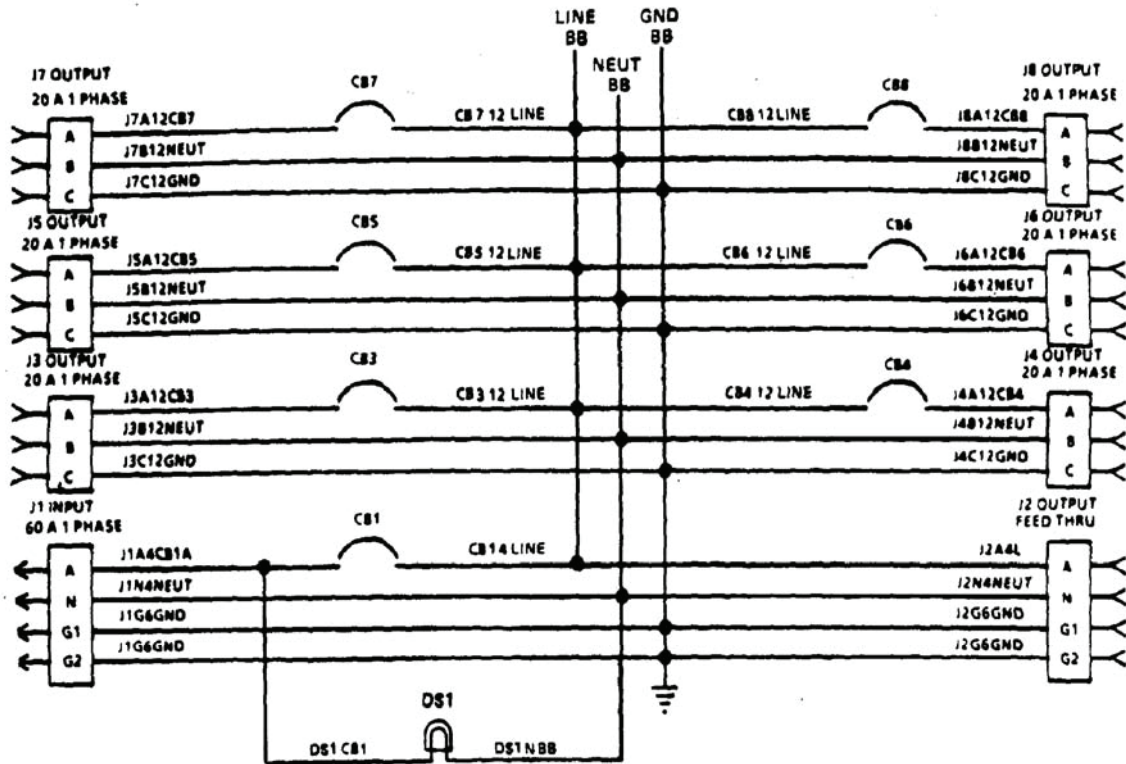

Figure 8. M60 A/P (PDISE) Distribution Center Wiring Diagram.

END OF WORK PACKAGE

**FIELD LEVEL MAINTENANCE INSTRUCTIONS
LATCH/ DATA PLATES (ENCLOSURE ASSEMBLY)
REPLACE, REPAIR**

INITIAL SETUP:**Tools and Special Tools**

General Mechanic's Automotive Tool Kit
(Item 1, WP 0035)
Hand Riveter Kit G-749
(Item 6, WP 0035)

Equipment Conditions

Power shut down

Personnel Required

One

Reference

TM 43-0139
WP 0002

REPLACE**NOTE**

The latch assembly is the same for all enclosure assemblies.

Latch Assembly Replacement

1. Drill off rivet head (Figure 1, Item 1) using a drill bit slightly smaller than the diameter of the rivet being removed.
2. Use a punch and drive out the rest of the rivet.
3. Remove latch assembly (Figure 1, Item 2)
4. Position latch over holes in center.
5. Install rivets (1) into holes and fasten with hand riveter.

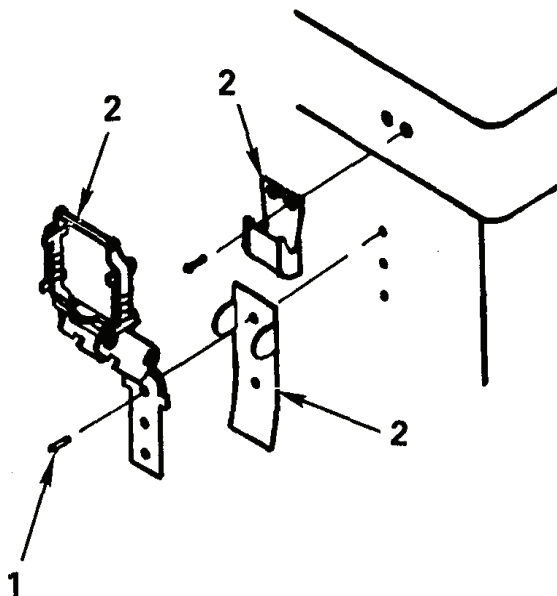

Figure 1. Latch Assembly

Data Plate Replacement

Data plates contain vital Warning, Informative, and Identification information. Any plate that is badly damaged, faded, or in any way missing and/or depreciated, should be replaced immediately. Should data plate be missing, see WP 0002 for exact placement on individual feeder/distribution centers.

1. To replace data plates, use a drill bit slightly smaller than the diameter of the rivet being removed.
2. Drill the rivets out and remove the old plate.
3. Align holes in replacement plate and install new rivets with hand riveter

REPAIR

1. Minor dents and bent edges can be straightened using common sheet metal repair procedures.
2. Should touch up or refinishing be necessary, see TM 43-0139, Painting Instructions for Army Material.

END OF WORK PACKAGE

Chapter 7

SUPPORTING INFORMATION

**SUPPORTING INFORMATION
DISE AND PDISE SYSTEMS
REFERENCES**

SCOPE

This work package lists all forms, pamphlets, field manuals, technical manuals, bulletins, army regulations, military specifications, and military standards referenced in this manual.

FORMS/ DA PAMPHLETS

SF 361	Discrepancy in Shipment Report
DA Form 5988E	Equipment Inspection and Maintenance Worksheet
SF 368	Product Quality Deficiency Report
DA Form 2028-2	Recommended Changes to Equipment Technical Publications
SF 364	Supply Discrepancy Report
DA Form 2407	Maintenance Request
DA Form 2410	Component Removal and Repair/Overhaul Record
DA PAM 750	Functional Users Manual for the Army Maintenance Management System
DA PAM 25-30	Consolidated Index of Army Publications and Blank Forms

TECHNICAL MANUALS

TM-43-0139	Painting Instructions for Army Materiel
TM 9-6150-226-23P	Unit and Direct Support Maintenance Repair Parts and Special Tools List for Distribution Illumination System, Electrical (DISE)
TM 750-244-3	Procedures for Destruction of Equipment to Prevent Enemy Use (MSE)

FIELD MANUALS

FM 5-20	Camouflage
FM 20-31	Electrical Power Generation in the Field
FM 3-5	Nuclear, Biological, and Chemical Decontamination

MILITARY SPECIFICATIONS

NONE

END OF WORK PACKAGE

**SUPPORTING INFORMATION
DISE AND PDISE SYSTEMS
INTRODUCTION FOR STANDARD MAINTENANCE ALLOCATION CHART (MAC)**

THE ARMY MAINTENANCE SYSTEM

This introduction provides a general explanation of all maintenance and repair functions authorized at the two maintenance levels under the Two-Level Maintenance System concept.

This MAC (immediately following the introduction) designates overall authority and responsibility for the performance of maintenance functions on the identified end item or component. The application of the maintenance functions to the end item or component shall be consistent with the capacities and capabilities of the designated maintenance levels, which are shown on the MAC in column (4) as:

Field – includes three subcolumns, Crew maintenance (C), Service maintenance (O), and Field maintenance (F).

Sustainment – includes two subcolumns, Below Depot (H) and Depot (D)

The tools and test equipment requirements (immediately following the MAC) list the tools and test equipment (both special tools and common tool sets) required for each maintenance function as referenced from the MAC.

The remarks (immediately following the tools and test equipment requirements) contain supplemental instructions and explanatory notes for a particular maintenance function.

MAINTENANCE FUNCTIONS

Maintenance functions are limited to and defined as follows:

1. **Inspect.** To determine the serviceability of an item by comparing its physical, mechanical, and/or electrical characteristics with established standards through examination (e.g., by sight, sound, or feel). This includes scheduled inspection and gauging and evaluation of cannon tubes.
2. **Test.** To verify serviceability by measuring the mechanical, pneumatic, hydraulic, or electrical characteristics of an item and comparing those characteristics with prescribed standards on a scheduled basis, i.e., load testing of lift devices and hydrostatic testing of pressure hoses.
3. **Service.** Operations required periodically to keep an item in proper operating condition; e.g., to clean (includes decontaminate, when required), to preserve, to drain, to paint, or to replenish fuel, lubricants, chemical fluids, or gases. This includes scheduled exercising and purging of recoil mechanisms. The following are examples of service functions:
 - Unpack. To remove from packing box for service or when required for the performance of maintenance operations.
 - Repack. To return item to packing box after service and other maintenance operations.
 - Clean. To rid the item of contamination.
 - Touch up. To spot paint scratched or blistered surfaces.
 - Mark. To restore obliterated identification.
4. **Adjust.** To maintain or regulate, within prescribed limits, by bringing into proper position, or by setting the operating characteristics to specified parameters.

-
5. **Align.** To adjust specified variable elements of an item to bring about optimum or desired performance.
 6. **Calibrate.** To determine and cause corrections to be made or to be adjusted on instruments of test, measuring, and diagnostic equipment used in precision measurement.

Consists of comparisons of two instruments, one of which is a certified standard of known accuracy, to detect and adjust any discrepancy in the accuracy of the instrument being compared.

7. **Remove/Install.** To remove and install the same item when required to perform service or other maintenance functions. Install may be the act of emplacing, seating, or fixing into position a spare, repair part, or module (component or assembly) in a manner to allow the proper functioning of an equipment or system.
8. **Paint** (ammunition only). To prepare and spray color coats of paint so that the ammunition can be identified and protected. The color indicating primary use is applied, preferably, to the entire exterior surface as the background color of the item. Other markings are to be repainted as original so as to retain proper ammunition identification.
9. **Replace.** To remove an unserviceable item and install a serviceable counterpart in its place "Replace" is authorized by the MAC and assigned maintenance level is shown as the third position code of the Source, Maintenance and Recoverability (SMR) code.
10. **Repair.** The application of maintenance services, including fault location/troubleshooting, removal/installation, disassembly/assembly procedures and maintenance actions to identify troubles and restore serviceability to an item by correcting specific damage, fault, malfunction, or failure in a part, subassembly, module (component or assembly), end item, or system.

NOTE

- The following definitions are applicable to the "repair" maintenance function:
- Services. Inspect, test, service, adjust, align, calibrate, and/or replace.
- Fault location/troubleshooting. The process of investigating and detecting the cause of equipment malfunctioning; the act of isolating a fault within a system or Unit Under Test (UUT).
- Disassembly/assembly. The step-by-step breakdown (taking apart) of a spare/functional group coded item to the level of its least component, that is assigned an SMR code for the level of maintenance under consideration (i.e., identified as maintenance significant).
- Actions. Welding, grinding, riveting, straightening, facing, machining, and/or resurfacing.

11. **Overhaul.** That maintenance effort (service/action) prescribed to restore an item to a completely serviceable/operational condition as required by maintenance standards in appropriate technical publications. Overhaul is normally the highest degree of maintenance performed by the Army. Overhaul does not normally return an item to like new condition.

12. **Rebuild.** Consists of those services/actions necessary for the restoration of unserviceable equipment to a like new condition in accordance with original manufacturing standards. Rebuild is the highest degree of material maintenance applied to Army equipment. The rebuild operation includes the act of returning to zero those age measurements (e.g., hours/miles) considered in classifying Army equipment/components.

EXPLANATION OF COLUMNS IN THE MAC

Column (1) Group Number. Column (1) lists Functional Group Code (FGC) numbers, the purpose of which is to identify maintenance significant components, assemblies, subassemblies, and modules with the Next Higher Assembly (NHA).

Column (2) Component/Assembly. Column (2) contains the item names of components, assemblies, subassemblies, and modules for which maintenance is authorized.

Column (3) Maintenance Function. Column (3) lists the functions to be performed on the item listed in column (2). (For a detailed explanation of these functions refer to "Maintenance Functions" outlined above.)

Column (4) Maintenance Level. Column (4) specifies each level of maintenance authorized to perform each function listed in column (3), by indicating work time required (expressed as manhours in whole hours or decimals) in the appropriate subcolumn. This work time figure represents the active time required to perform that maintenance function at the indicated level of maintenance. If the number or complexity of the tasks within the listed maintenance function varies at different maintenance levels, appropriate work time figures are to be shown for each level. The work time figure represents the average time required to restore an item (assembly, subassembly, component, module, end item, or system) to a serviceable condition under typical field operating conditions. This time includes preparation time (including any necessary disassembly/assembly time), troubleshooting/fault location time, and quality assurance time in addition to the time required to perform the specific tasks identified for the maintenance functions authorized in the MAC. The symbol designations for the various maintenance levels are as follows:

Field:

C - Operator or Crew maintenance

O - Service Maintenance

F - Field Maintenance

Sustainment:

H - Below Depot Maintenance

D - Depot Maintenance

NOTE

The "L" maintenance level is not included in column (4) of the MAC. Functions to this level of maintenance are identified by work time figure in the "H" column of column (4), and an associated reference code is used in the REMARKS column (6). This code is keyed to the remarks and the SRA complete repair application is explained there.

Column (5) Tools and Equipment Reference Code. Column (5) specifies, by code, those common tool sets (not individual tools); common Test, Measurement and Diagnostic Equipment (TMDE); and special tools, special TMDE, and special support equipment required to perform the designated function. Codes are keyed to the entries in the tools and test equipment table.

Column (6) Remarks Code. When applicable, this column contains a letter code, in alphabetical order, which is keyed to the remarks table entries.

EXPLANATION OF COLUMNS IN THE TOOLS AND TEST EQUIPMENT REQUIREMENTS

Column (1) Tool or Test Equipment Reference Code. The tool or test equipment reference code correlates with a code used in column (5) of the MAC.

Column (2) Maintenance Level. The lowest level of maintenance authorized to use the tool or test equipment.

Column (3) Nomenclature. Name or identification of the tool or test equipment.

Column (4) National Stock Number (NSN). The NSN of the tool or test equipment.

Column (5) Tool Number. The manufacturer's part number, model number, or type number.

EXPLANATION OF COLUMNS IN THE REMARKS

Column (1) Remarks Code. The code recorded in column (6) of the MAC.

Column (2) Remarks. This column lists information pertinent to the maintenance function being performed as indicated in the MAC.

END OF WORK PACKAGE

**SUPPORTING INFORMATION
DISE/PDISE EQUIPMENT
MAINTENANCE ALLOCATION CHART (MAC)**

Table 1. MAC for DISE/PDISE EQUIPMENT

(1) GROUP NUMBER	(2) COMPONENT/ ASSEMBLY	(3) MAINTENANCE FUNCTION	(4) MAINTENANCE LEVEL				(5) TOOLS AND EQPT REF CODE	(6) REMARKS CODE
			FIELD		SUSTAINMENT			
			CREW	FIELD	BELOW DEPOT	DEPOT		
			C	F	H	D		
00	DISTRIBUTION ILLUMINATION SYSTEM, ELECTIC AND POWER							
01	FEEDER SYSTEM							
	DATA PLATES	INSPECT REPLACE	0.1	0.2				
	GASKET	INSPECT REPLACE	0.1					
	ENCLOSURE ASSEMBLY	REPLACE REPAIR		2.0				
	LATCH	REPLACE		0.5		2	A	
	CIRCUIT BR. PANEL BOARD	INSPECT REPLACE				2, 21 THRU 23		
	CIRCUIT BREAKER	INSPECT TEST REPLACE	0.1 0.1			1		
	CONNECTOR ASSY	INSPECT TEST REPLACE REPAIR	0.1	2.0		3 1, 24, 25		
	PHASE INDICATOR LIGHT ASSY	INSPECT REPLACE	0.1			3 1 2, 7 THRU 19		
	PHASE INDICATOR LIGHT BULB	REPLACE				1		
	CIRCUIT BREAKER ASSEMBLY	REPLACE TEST				1, 3, 24 THRU 27		

Table 1. MAC for DISE/PDISE EQUIPMENT (Cont)

(1) GROUP NUMBER	(2) COMPONENT/ ASSEMBLY	(3) MAINTENANCE FUNCTION	(4) MAINTENANCE LEVEL				(5) TOOLS AND EQPT REF CODE	(6) REMARKS CODE
			FIELD		SUSTAINMENT			
			CREW	FIELD	BELOW DEPOT	DEPOT		
			C	F	H	D		
02	BUS BAR	REPLACE					1, 24 THRU 27	B
	CABLE ASSY	INSPECT	0.1				3	
		TEST REPLACE REPAIR	0.1	0.2 2.0			2,3 THRU 20	
	LANYARD ASSY	INSPECT REPLACE	0.1					
	DISTRIBUTION SYSTEM							
	DATA PLATES	INSPECT REPLACE	0.1	0.2				
	ENCLOSURE ASSY	REPLACE REPAIR		2.0			2	
	LATCH	REPLACE		0.5			2, 21 THRU 23	
	CIRCUIT BR. PANEL BOARD	INSPECT REPLACE					1	
	CIRCUIT BREAKER	INSPECT	0.1				3	
		TEST REPLACE	0.1				1, 24, 25	
	CONNECTOR ASSY	INSPECT TEST REPLACE REPAIR	0.1	2.0			3 1 2, 7 THRU 19	
	PHASE INDICATOR LIGHT ASSY	INSPECT REPLACE	0.1				1	
	PHASE INDICATOR LIGHT BULB	REPLACE						
CIRCUIT BREAKER ASSY	REPLACE					1, 24 THRU 27		
BUS BAR	REPLACE					1, 24 THRU 27		

Table 1. MAC for DISE/PDISE EQUIPMENT (Cont)

(1) GROUP NUMBER	(2) COMPONENT/ ASSEMBLY	(3) MAINTENANCE FUNCTION	(4) MAINTENANCE LEVEL				(5) TOOLS AND EQPT REF CODE	(6) REMARKS CODE
			FIELD		SUSTAINMENT			
			CREW	FIELD	BELOW DEPOT	DEPOT		
			C	F	H	D		
03	CABLE ASSY	INSPECT TEST REPLACE REPAIR	0.1 0.1				3 2, 3 THRU 20 3	B
	DUPLEX RECEPTACLE GROUP	INSPECT TEST REPLACE REPAIR	0.1 0.1				1, 2, 12	
	CONTAINER, TRANSIT AND STORAGE	INSPECT	0.1					
	CONNECTOR ASSY	REPLACE REPAIR		1.0 1.0			1, 12	
	UTILITY ASSEMBLY, ELECTRICAL							
	CABLE ASSY	INSPECT TEST REPLACE REPAIR	0.1 0.1	1.0			3 2, 12	B
	BRANCH CIRCUIT CABLE ASSY	INSPECT TEST REPLACE REPAIR	0.1 0.1				3 2, 12	
	BRANCH CIRCUIT TRUNK ASSY	INSPECT TEST REPLACE REPAIR	0.1 0.1	2.0			3 2, 12	
	RECEPTACLE GROUP	INSPECT TEST REPLACE REPAIR	0.1 0.1				3 1, 2, 12	
	DATA PLATES	INSPECT REPLACE	0.1	0.2				
	UTILITY LIGHT ASSEMBLY, INCANDESCENT, DUAL BULB	INSPECT TEST REPLACE REPAIR	0.1 0.1				3 1	

Table 1. MAC for DISE/PDISE EQUIPMENT (Cont)

(1) GROUP NUMBER	(2) COMPONENT/ ASSEMBLY	(3) MAINTENANCE FUNCTION	(4) MAINTENANCE LEVEL				(5) TOOLS AND EQPT REF CODE	(6) REMARKS CODE
			FIELD		SUSTAINMENT			
			CREW	FIELD	BELOW DEPOT	DEPOT		
			C	F	H	D		
04	CONTAINER TRANSIT AND STORAGE	INSPECT	0.1					
	UTILITY LIGHT ASSEMBLY, 36' FLOURESCENT	INSPECT REPLACE	0.1					
	AUXILLARY EQUIPMENT							
	CABLE ASSY'S	INSPECT	0.1				3	B
		TEST REPLACE REPAIR	0.1	0.2 0.2			2, 4 THRU 15	
	UNIVERSAL ADAPTER	INSPECT	0.1				3	
		TEST REPLACE REPAIR	0.1				1	
	MOUNTING BOARD & INPUT CONNECTOR ASSY	INSPECT TEST REPLACE REPAIR	0.2		4.0		3 1 2, 7 THRU 19	
	SLEEVE, DUST AND MOISTURE	REPLACE					1	
	TERMINAL, LOAD	INSPECT REPLACE	0.1				1	

Table 2. Tool and Test Equipment Requirements

TOOL OR TEST EQUIPMENT REF CODE	MAINTENANCE CATEGORY	NOMENCLATURE	NATIONAL/ NATO STOCK NUMBER	TOOL NUMBERS
1	0	TOOL KIT, GENERAL MECHANICS AUTOMOTIVE	5180-00-177-7033	SC5180-90-CL-N26
2	0	SHOP EQUIP., AUTIO, ORG # 2 COMMON	4910-00-754-0050	SC4910-95-CL-A72
3	0	SHOP EQUIP., AUTIO, ORG # 1 COMMON	4910-00-754-0654	SC4910-95-CL-A74
4	F	SHOP EQUIPMENT AUTOMOTIVE MAINTENANCE	4910-00-754-0705	SC4910-95-CL-A31
5	F	SHOP EQUIPMENT, MECH. MAINTENANCE SHELTER	4940-00209-6227	SC4910-95-CL-A52
6	F	TOOL KIT, RIVETER	5120-00017-2849	J-T49CMR
7	F	TOOL REMOVER, SIZE 4/0	81349	M81969/27-01
8	F	TOOL REMOVER, SIZE 20	81349	M81969/27-02
9	F	TOOL REMOVER, SIZE 10	81349	M81969/27-03
10	F	TOOL REMOVER, SIZE # 4	81349	M81969/27-05
11	F	TOOL REMOVER, SIZE # 6	81349	M81969/27-06
12	F	TOOL INSTALLER SIZE # 12	81349	M81969/8-09
13	F	TOOL REMOVER, SIZE # 12	81349	M81969/8-10
14	F	TOOL KIT CRIMPING	81349	M83507/11-1
15	F	TOOL, CRIMPING	59703	WT1111M
16	F	TOOL STRIPPER CABLE	30119	45-156
17	F	TOOL STRIPPER WIRE	59730	WT2000
18	F	TOOL STRIPPER CABLE	30119	45-127
19	F	TOOL REMOVER, SIZE # 2	81349	M81969/27-04
20	F	STRIPPER, CABLE, HAND ADJUSTABLE		45-156
21	F	DRILL, ELECT, PORTABLE 8845 OR EQUIVALENT	5130-00-226-5586	8845
22	F	DRILL, BIT NO. 13	5130-01-046-2902	
23	F	RIVETER, BLIND HEAD G749 OR EQUIVALENT	5120-00-148-5847	G649
24	O	WRENCH, TORQUE 6063 OR EQUIVALENT	5120-00-177-7328	6063
25	O	SCREWDRIVER, 3/8 X 12 FLAT	5120-00-243-7337	
26	O	ATTACHMENT, SOCKET HEAD WRENCH, 3/8 DRIVE x 5/16	5120-01-016-8713	
27	O	ATTACHMENT, SCREWDRIVER TIP, 3/8 DRIVE	5120-00-243-7337	

Table 3. REMARKS

REFERENCE CODE	REMARKS
A	Repair of enclosure consist of welding and straightening
B	Fabrication of DISE/PDISE cable assemblies is authorized at the Field maintenance level.
C	Solder dip or solder gun wire ends not to exceed 0.025 inch using Kester Solder, MIL Spec No. QQ-S-571 (Sn 60, Pb 40).

END OF WORK PACKAGE

**SUPPORTING INFORMATION
DISE/PDISE EQUIPMENT
COMPONENTS OF END ITEMS (COEI) and BASIC ISSUE ITEMS (BII) LIST**

SCOPE.

This appendix lists components of end item and basic issue items for the DISE and PDISE equipment to help you inventory items required for safe and efficient operation.

GENERAL.

The components of End Items and Basic Issue Items (BII) lists are divided into the following sections:

- a. Section II, Components of End Item. This listing is for informational purposes only, and is not authority to requisition replacements. These items are part of the end item, but are removed and separately packaged for transportation or shipment. As part of the end item, these items must be with the end item whenever it is issued or transferred between property accounts. Illustrations are furnished to assist you in identifying the items.
- b. Section III, Basic Issue Items. These are the minimum essential items required to place the DISE and PDISE equipment in operation, to operate it, and to perform emergency repairs. Although shipped separately packaged, BII must be with the DISE and PDISE equipment during operation and whenever it is transferred between property accounts. The illustrations will assist you with hard-to-identify items. This manual is your authority to request/requisition replacement BII, based on TOE/MTOE authorization of the end item.

EXPLANATION OF COLUMNS.

The following provides an explanation of columns found in the tabular listings.

- a. Column (1), Illustration Number (Illus Number). This column indicates the number of the illustration in which the item is shown.
- b. Column (2), National Stock Number. Indicates the National Stock Number assigned to the item and will be used for requisitioning purposes.
- c. Column (3), Description. Indicates the Federal item name and, if required, a minimum description to identify and locate the item. The last line for each-item indicates the Commercial and Government Entity Code (CAGEC) (in parentheses) followed by the part number. If item needed differs for different models of this equipment, the model is shown under the Usable On Code heading in this column. These codes are identified as:

<u>Code</u>	<u>Used On</u>
DZC	Model M200
DZB	Model M100
DYZ	Model M40
DZA	Model M60
DZD	Model M46
ENK	Model M200 A/P
ENL	Model M100 A/P
ENM	Model M40
ENN	Model M60 A/P

- d. Column (4), Field of Measure (U/M). Indicates the measure used in performing the actual operational/maintenance function. This measure is expressed by a two-character alphabetical abbreviation (e.g., ea, in., pr).
- e. Column (5), Quantity Required (Qty Rqr). Indicates the quantity of the item authorized to be used with/on the equipment.

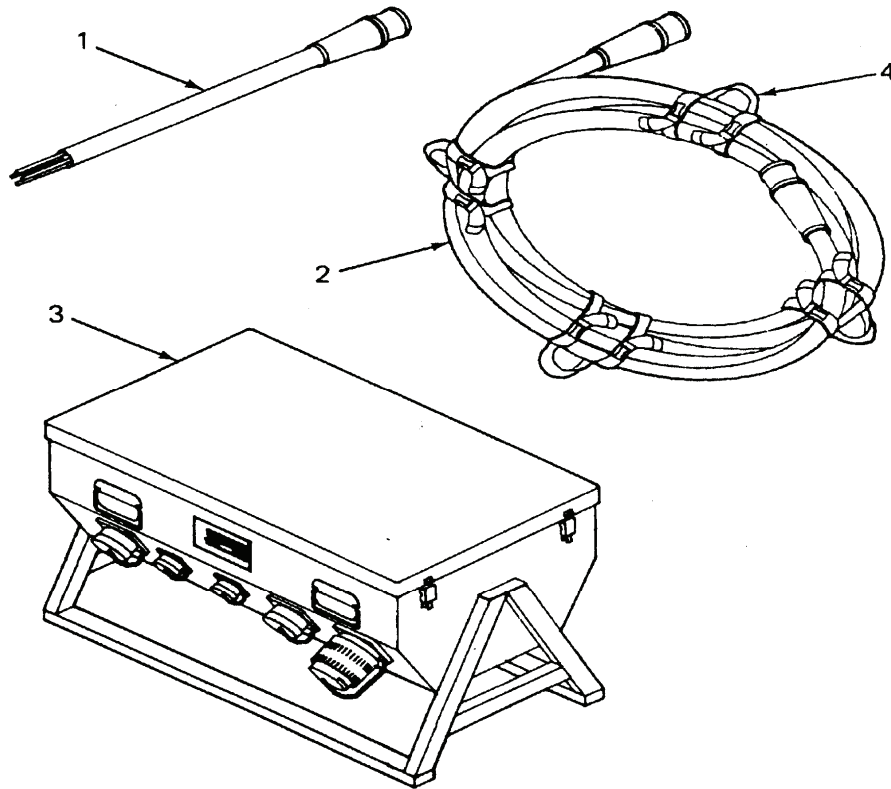

Figure 1. M200/200A/P Components of End Item (COEI)

Table 1. M200/200A/P Components of End Items (COEI) List.

(1) Illustration Number	(2) National Stock Number	(3) Description CAGE and Part Number	Usable On Code	(4) U/M	(5) Qty Req
1	6150-01-247-4768	CABLE, PIGTAIL:4-ft(1.2m), 200-amp, 8-pin(97403) 13226E7021	DZC,ENK	EA	1
2	6150-01-247-4782	CABLE, SERVICE/FEEDER: 25-ft (7.6 m), 200-amp, 8-pin(97403) 13226E7025	DZC,ENK	EA	4
3	6150-01-308-5672	CENTER, ELECTRICAL FEEDER:3-phase 120/208 V, 200-amp/ph(97403) 13226E7030	DZC,ENK	EA	1
4		STRAP, CABLE CARRYING (97403) 13227E5821	DZC,ENK	EA	16

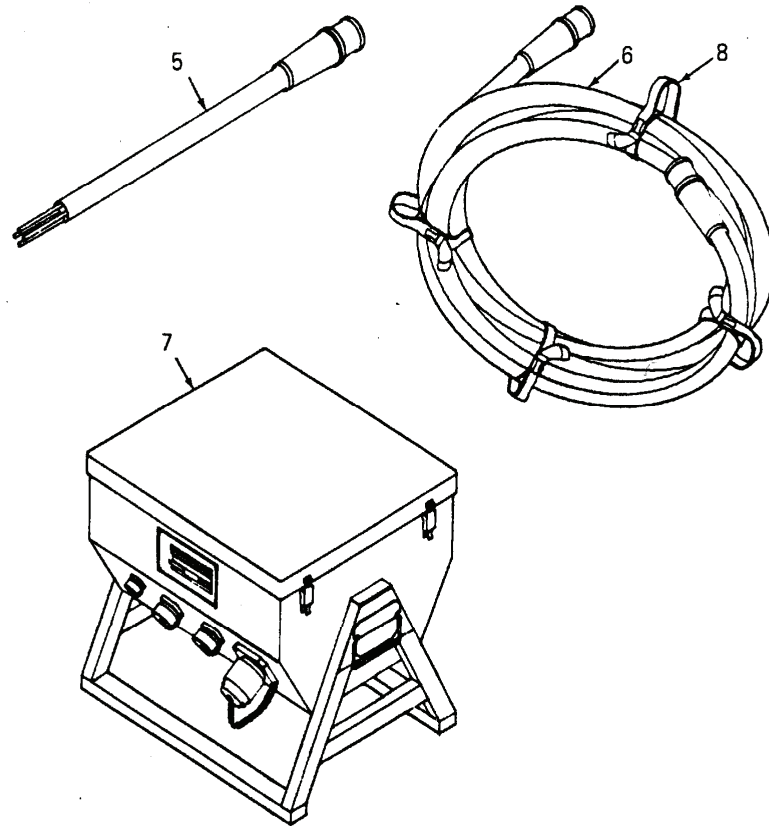

Figure 2. M100/100A/P Components of End Item (COEI) List.

Table 2. M100/100A/P Components of End Item (COEI) List.

(1) Illustration Number	(2) National Stock Number	(3) Description CAGE and Part Number	Usable On Code	(4) U/M	(5) Qty Req
5	6150-01-256-6300	(See Figure 2) CABLE, PIGTAIL 4-ft (1.2m), 100-amp, 8-pin (97403) 13226E7020	DZB,ENL	EA	1
6	6150-01-256-6304	CABLE, SERVICE/FEEDER: 50-ft (15.2 m), 100-amp, 8-pin (97403) 13226E7024	DZB,ENL	EA	2
7	6150-01-308-5671	CENTER, ELECTRICAL FEEDER: 3-phase 120/208 U, 100-amp/ph (97403) 13226E7029	DZB,ENL	EA	1
8	6150-01-256-6266	STRAP, CABLE CARRYING (97403) 13226E5825	DZB,ENL	EA	8

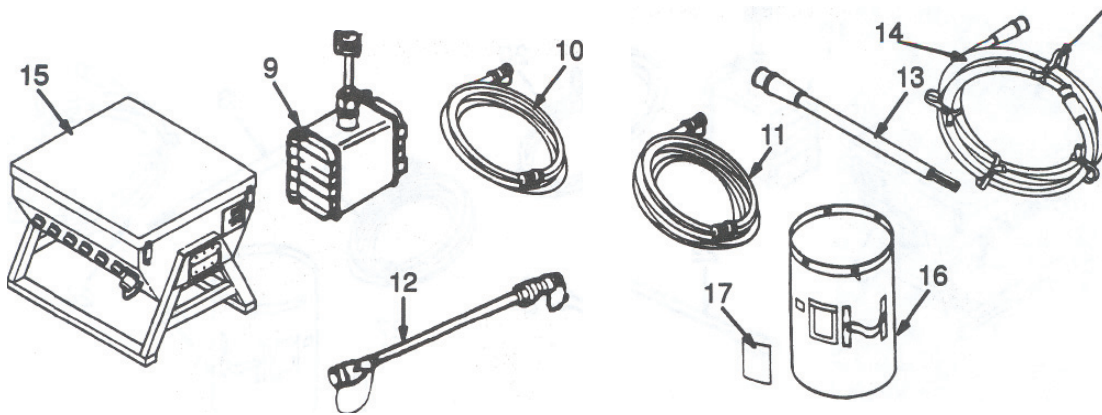

Figure 3. M40/M40A/P Components of End Item (COEI) List.

Table 3. M40/M40A/P Components of End Item (COEI) List.

(1) Illustration Number	(2) National Stock Number	(3) Description CAGE and Part Number	Usable On Code	(4) U/M	(5) Qty Req
(See Figure 3)					
9	6150-01-251-9125	BOX, DUPLEX RECEPTACLE: 120 V, 20- amp (97403) 13226E7040	DYZ, ENM	EA	1
10	6150-01-250-0044	CABLE, EXTENSION: 25ft (7.6m), 20-amp, 3-pin (97403) 13226E7032-2	DYX, ENM	EA	3
11	6150-01-250-3643	CABLE, EXTENSION: 50-ft (15.2m), 20-amp, 3-pin (97403) 13226E7032-1	DYZ, ENM	EA	3
12	6150-01-253-4290	CABLE, LIGHT SET, 25 OUTLET	DYZ, ENM	EA	2

(Cont. See Figure 3)					
13	6150-01-256-6301	CABLE, PIGTAIL: 4-ft (1.2m), 40/60-amp, 3-pin (97403) 13226E7019	DYZ, ENM	EA	1
14	6150-01-247-4761	CABLE, SERVICE/FEEDER: 50-ft (30.48m), 40-60-amp, 3-pin (97403) 13226E7023-2	DYZ, ENM	EA	2
15	6150-01-307-9446	CENTER, DISTRIBUTION: 3-phase 120/208 V, 10- amp/ph (97403) 13226E7028 (97403) 13229E6345	DYZ, ENM	EA	1
16	6150-01-256-6298	CONTAINER, TRANSIT AND STORAGE (97403) 13227E5830	DYZ, ENM	EA	1
17		LIST, PACKING (97403) 13227E5826	DYZ, ENM	EA	1
18	6150-01-256-6299	STRAP, CABLE CARRYING (97403) 13227E5825	DYZ, ENM	EA	16

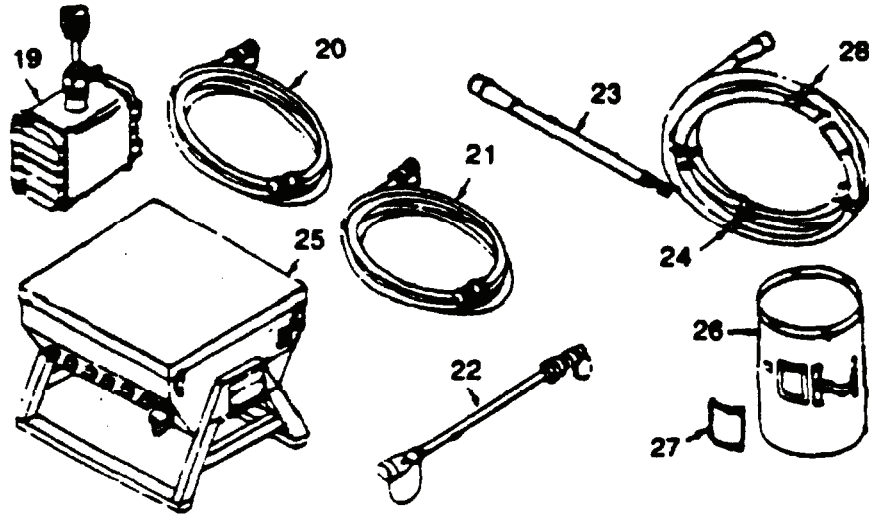

Figure 4. M60/M60A/P Components of End Item (COEI) List

Table 4. M60/ M6A/P Components of End Item (COEI) List

(1) Illustration Number	(2) National Stock Number	(3) Description CAGE and Part Number	Usable On Code	(4) U/M	(5) Qty Req
19	6150-01-251-9125	(See Figure 4) BOX, DUPLEX RECEPTACLE: 120 V, 20- amp (97403) 13226E7040	DZA,ENN	EA	1
20	6150-01-250-0044	CABLE, EXTENSION: 25-ft (7.6m), 0-amp, 3 pin (97403) 13226E7032-2	DZA,ENN	EA	3
21	6150-01-250-3643	CABLE, EXTENSION: 50-ft (15.2m), 0-amp, 3-pin (97403) 13226E7032-1	DZA,ENN	EA	3
22	6150-01-253-4290	CABLE, LIGHT SET, 25 OUTLET	DZA,ENN	EA	2
23	6150-01-247-4778	CABLE, PIGTAIL: 4-ft (1.2m), 50-amp, 4-pin (97403) 13226E7018	DZA,ENN	EA	1

		(Cont. See Figure 4)			
24	6150-01-247-4793	CABLE, SERVICE/FEEDER: 100-ft (30.5m), 60-amp, 4-pin (97403) 13226E7022-1	DZA,ENN	EA	1
25	6150-01-307-9445	CENTER, DISTRIBUTION; Single-phase 120V, 60- amp (97403) 13226E7027	DZA,ENN	EA	1
26	6150-01-256-6298	CONTAINER, TRANSIT AND STORAGE (97403) 13227E5830	DZA,ENN	EA	2
27		LIST, PACKING (97403) 13227E5826	DZA,ENN	EA	1
28	6150-01-256-6299	STRAP, CABLE CARRYING (97403) 13227E5825	DZA, ENN	EA	16

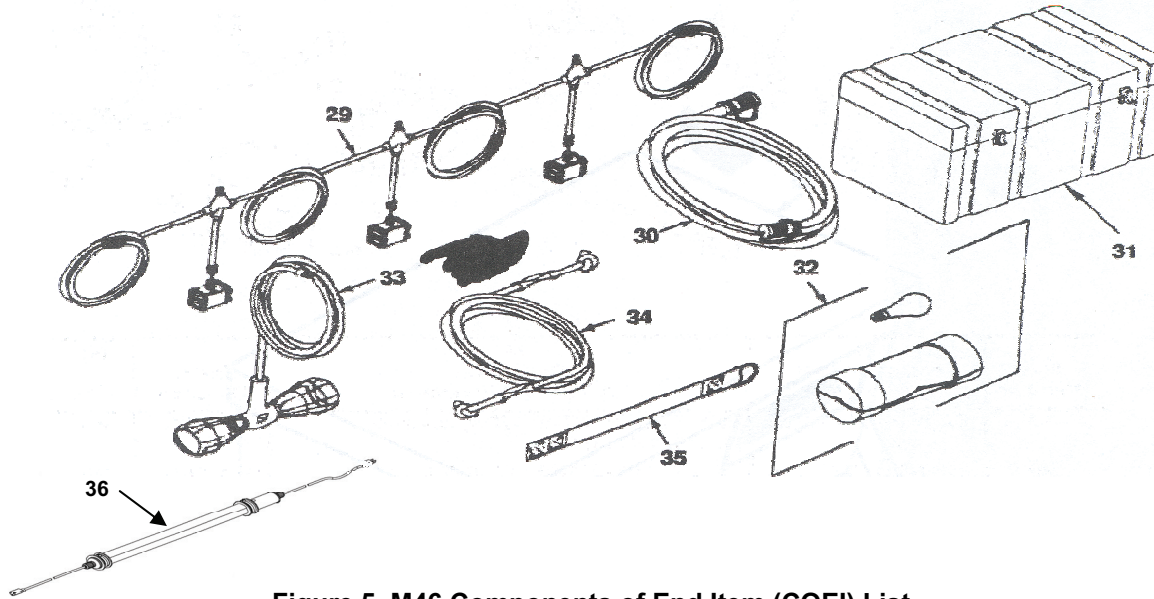

Figure 5. M46 Components of End Item (COEI) List.

Table 5. M46 Components of End Item (COEI) List.

(1) Illustration Number	(2) National Stock Number	(3) Description CAGE and Part Number	Usable On Code	(4) U/M	(5) Qty Req
		(See Figure 5)			
29	6150-01-251-9124	CABLE ASSEMBLY, BRANCH CIRCUIT: 24-ft (7.3 m), 20-amp, 3-pin, (97403) 13226E7034	DZA, ENN	EA	2
30	6150-01-247-4766	CABLE, EXTENSION: 25-ft (7.6 m), 20-amp, 3-pin (97403) 13226E7032-2	DZD	EA	6
31	6150-01-208-9751	CONTAINER, TRANSIT AND STORAGE (97403) 13229E6362	DZD	EA	1
32	6150-01-264-2068	KIT, LIGHT BULB (97403) 13227E5829	DZD	EA	3

(1) Illustration Number	(2) National Stock Number	(3) Description CAGE and Part Number	Usable On Code	(4) U/M	(5) Qty Req
		(Cont. See Figure 5)			
	6240-00-617-1744	40 W, Blue (81348) W-L-I 018	DZD	EA	3
	6240-00-689-8504	75 W, White (06172) 40A18-120V	DZD	EA	3
33	6230-01-247-4784	LIGHT, UTILITY: 120 V, dual socket, incandescent (97403) 13226E7043	DZD	EA	2
34	6150-01-256-6302	ROPE ASSEMBLY, SUPPORT 53-h (1.2 m) (97403) 13226E7041	DZD	EA	2
35	6150-01-250-0045	STRAP, CABLE SECURING (97403) 13226E7044	DZD	EA	8
36	6230-01-465-8931	50 W TWIN COMPACT FLOURESCENT BULB (97403) (1323OE7018	DZD	EA	2

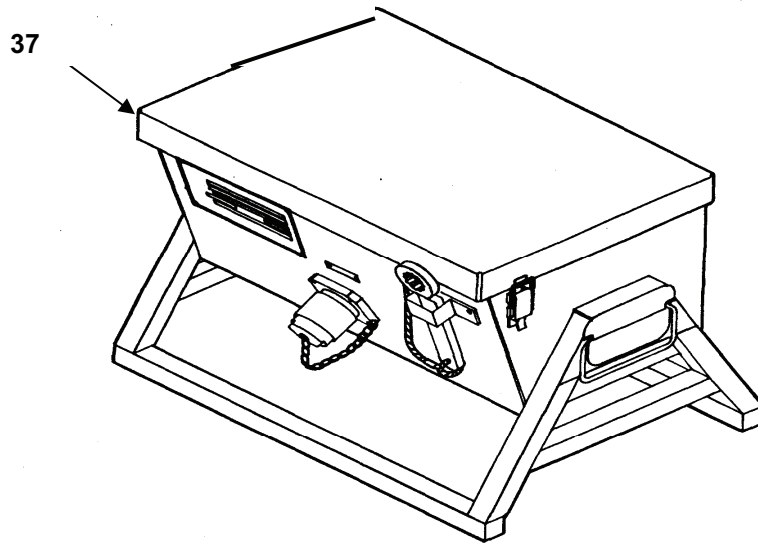

Figure 6. Universal Adapter

Table 6. Universal Adapter

(1) Illustration Number	(2) National Stock Number	(3) Description CAGE and Part Number	(3) Usable On Code	(4) U/M	(5) Qty Req
37	5975-01-247-4791	(See Figure 6) ADAPTER, UNIVERSAL (97403) 13227E6201	DZC,DZB DYZ,DZA DZD, ENK,ENL ENM, ENN	EA	1

BASIC ISSUE ITEMS (BII)

The only BII item authorized is TM 11-6150-226-13, Operator and Field Maintenance Manual for Distribution Illumination Systems, Electrical (DISE) and Power Distribution Illumination Systems.

END OF WORK PACKAGE

**SUPPORTING INFORMATION
DISE/PDISE EQUIPMENT
ADDITIONAL AUTHORIZATION LIST (AAL) ITEMS**

There are no Additional Authorized Items (AAL) for DISE/PDISE equipment at this time.

END OF WORK PACKAGE

**SUPPORTING INFORMATION
DISE/PDISE EQUIPMENT
EXPENDABLE/DURABLE SUPPLIES AND MATERIALS LIST**

SCOPE

This appendix lists expendable supplies and materials you will need to operate and maintain the DISE and PDISE systems. This listing is for informational purposes only and is not authority to requisition the listed items. These items are authorized to you by CTA 50-970, Expendable/Durable Items (Except Medical, Class V, Repair Parts, and Heraldic Items), or CTA 8-100, Army Medical Department Expendable/Durable Items.

EXPLANATION OF COLUMNS.

- a. Column (1) - Item Number. This number is assigned to the entry in the listing and is referenced in the narrative instructions to identify the material (e.g., Use dry cleaning solvent, item 1, app E).
- b. Column (2) - Level. This column identifies the lowest level of maintenance that would most likely require the listed item.
 - O – Service Level Maintenance
 - F – Field Level Maintenance
- c. Column (3)-National Stock Number. This is the national stock number assigned to the item; use it to request or requisition the item.
- d. Column (4) - Description. Indicates the Federal item name and, if required, a description to identify the item. The last line for each item indicates the Commercial and Government Entity Code (CAGEC) in parentheses, followed by the part number.
- e. Column (5) - Field of Measure (U/M) Indicates the measure used in performing the actual maintenance function. This measure is expressed by a two-character alphabetical abbreviation (e.g., ea, in., pr). If the field of measure differs from the field of issue, requisition the lowest field of issue that will satisfy your requirements.

Table 1. Expendable/Durable Supplies and Materials List

(1) Item Number	(2) Level	(3) National stock number	(4) Description	(5) U/M
1	O	8040-01-038-5043	Cement, gasket, 8 oz (237cc) can	oz
2	O	7930-00-249-8036	Detergent, general-purpose 5 lb (2.3 kg)	lb
3	O	6850-00-057-9360	Compound, cleaning and lubricating, electrical contact, 6-OZ (177 cc) can	oz
4	O	6240-00-152-2987	Lamp, fluorescent, 120 V, 50W	ea
5	O	6240-00-689-8504	Lamp, Incandescent, blue 120 V, 40W	ea
6	O	6240-00-824-4675	Lamp, Incandescent, white 120 V, 75W	ea
7	O	8010-01-229-7546	Paint, CARC forest green, type II I-quart (0.94 liter) kit	qt
8	O	7920-00-205-1711	Rag, wiping	ea
9	F	5970-00-944-1450	Sleeving, insulation, heat shrinkable blue 1 in. diameter	v
10	O	7510-00-266-6711	Tape, masking, 3/4 in. (19.1 mm)	ea
11	F	5970-00-689-3444	Tape, wire marker, black 1/2 X 1296 in. (12.7 mm X 6 m)	ro
12	F	5970-01-017-7388	Tape, wire marker, blue 1/2 X 240 in. (12.7 mm X 6 m)	ro
13	F	5970-01-013-9366	Tape, wire marker, green 1/2 X 240 in. (12.7 mm X 6 m)	ro
14	F	5970-00-834-2569	Tape, wire marker, red 1/2 X 240 in. (12. mm X 6 m)	ro
15	F	5970-00-832-4299	Tape, wire marker, white 1/2 X 648 in. (12.7 mm X 16 m)	ro
16	O	8040-01-038-5643	Adhesive	oz
17	F		Solder, Kester MIL Spec QQ-S-571 (Sn 60 Pb 40)	lb

END OF WORK PACKAGE

**SUPPORTING INFORMATION
DISE/PDISE EQUIPMENT
ILLUSTRATED LIST OF MANUFACTURED ITEMS**

INTRODUCTION

This Work Package includes complete instructions for making items authorized to be manufactured or fabricated at the Field Maintenance Level. A part number index in alphanumeric order is provided for cross-referencing the part number of the item to be manufactured to the figure which covers fabrication criteria. All bulk materials needed for manufacture of an item are listed by part number or specification number in each "Component Legend" for each illustration.

Table 1. MANUFACTURED ITEMS PART NUMBER INDEX

PART NO.	NSN	DESCRIPTION	FIG. NO.
CO-02HDF (2/4-2/8R) 1290		Cable, Electrical	F-3, F-18, G-22
CO-03MGF (3/12) 0385		Cable, Electrical	F-4, F-23 THRU F-25
CO-04HDE (4/0000- 4/4R) 2380		Cable, Electrical	F-15, F-19
CO-04HDF (4/1 -4/8R) 1620	6145-01-199-1418	Cable, Electrical	F-16, F-20
CO-04HDF (4/4-4/1A)		Cable, Electrical	F-17
CO-04HDF (4/4+12R) 1290		Cable, Electrical	F-1, F-2, F-21
M23053/5-109-4	5970-00-057-3545	Sleeving, Insulation, Heat Shrink	F-4, F-23 THRU F-25
M23053/5-112-4	5970-00-810-6118	Sleeving, Insulation, Heat Shrink	F-1 THRU F-3, F-17, F-18, F-21, F-22
M23053/5-113-4	5970-00-810-6013	Sleeving, Insulation, Heat Shrink	F-16, F-20
M23053/5-114-4	5970-00-810-6132	Sleeving, Insulation, Heat Shrink	F-15, F-19
M39029/30-219	5999-00-190-1887	Socket, electrical connector	F-4, F-1 2 thru F-14, F-23 thru F-25, F-33 thru F-35
M39029/44-290	5999-01-044-9729	Contact, electrical pin	F-4, F-23 thru F-25
M39029/48-318	5999-00-014-0939	Contact, electrical pin	F-1 thru F-3, F-8, F-10, F-21, F-22, F-29, F-31

PART NO.	NSN	DESCRIPTION	FIGURE NO.
M39029/48-319	5999-01-108-8602	Contact, electrical Pin	F-6, F-20, F-27
M39029/48-320	5999-01-014-0941	Contact, electrical Pin	F-1 THRU F-3, F-8, F-10, F-21, F-22, F-29 F-31
M39029/48-321	5999-01-014-0943	Contact, electrical Pin	F-1 THRU F-3, F-8, F-10, F-21, F-22, F-29 F-31
M39029/48-322	5999-00-344-1907	Contact, electrical Pin	F-5, F-19, F-26
M39029/48-323	5999-01-130-1899	Contact, electrical Pin	F-6, F-27
M39029/48-324	5999-01-113-4552	Contact, electrical Pin	F-6, F-27
M39029/48-327	5999-00-344-1904	Contact, electrical Pin	F-5, F-19, F-26
M39029/48-328	5999-00-344-1906	Contact, electrical Pin	F-5, F-19, F-26
M39029/49-329	5999-00-014-0952	Contact, electrical Pin	F-3, F-9, F-11, F-17, F-18, F-21, F-22, F-30, F-32
M39029/49-330	5999-01-131-5888	Contact, electrical Pin	F-7, F-16, F-20, F-28
M39029/49-331	5999-01-191-3187	Contact, electrical Pin	F-1 THRU F-3, F-9, F-11, F-18, F-21, F-22 F-30, F-32
M39029/49-332	5999-00-346-8787	Contact, electrical Pin	F-15-F-19
M39029/49-333	5999-00-346-1897	Contact, electrical Pin	F-7, F-16, F-20, F-28
M39029/49-335	5999-00-344-1909	Contact, electrical Pin	F-15, F-19
M5086/2-1-9	6145-01-197-3918	Wire, electrical	F-6, F-7, F-27, F-28
M5086/2-12-9	6145-00-578-7514	Wire, electrical	F-12, THRU F-14, F-33 THRU F-35

PART NO.	NSN	DESCRIPTION	FIGURE NO.
M5086/2-2/0-9	6145-00-578-6600	Wire, electrical	F-5
M5086/2-4/0-9		Wire, electrical	F-26
M5086/2-4-9	6145-00-578-6595	Wire, electrical	F-8 THRU F-11, F-29 THRU F-32
M5086/2-6-9	6145-00-578-6594	Wire, electrical	F-29 THRU F-32
M5086/2-8-9	6145-00-284-0657	Wire, electrical	F-8 THRU F-11
M39029/49-331	5999-01-091-3187	Contact, electrical Socket	F-18
MS25042-16D	5935-01-189-3220	Cover, electrical Connector, straight plug	F-4, F-23 THRU F-25
MS25043-16D	5935-01-160-7188	Cover, electrical, Connector	F-4, F-12 THRU F-14 F-23 THRU F-25, F-33 TRHU F-35
MS3102R16-10S	5935-01-160-1788	Connector, electrical Receptacle	F-18
MS3348-6-8L	5999-01-167-0838	Reducer, connector pin	F-1 THRU F-3 F-7 THRU F-11 F-16, F-18, F20 THRU F-25, F28 THRU F-32
MS3349-410-210	5990-01-217-4773	Reducer, contact Electrical	F-5, F-26
MS3451W16-10S	5935-01-260-9595	Connector, electrical Receptacle	F-4, F-23 THRU F-25
MS3452W16-10S	5935-01-160-1788	Connector, electrical Receptacle	F-12 THRU F-14 F33 THRU F-35
MS2346W16-10P	5935-01-026-2177	Connector, electrical Straight plug	F-4, F-23 THRU F-25
MS90555C32405S		Connector, electrical Receptacle	F-11, F-32
MS90555C32413S	5935-01-087-0201	Connector, electrical Receptacle	F-9, F-30
MS90555C44413S	5935-01-092-3451	Connector, electrical Straight plug	F-7, F-28
MS90556C32405P		Connector, electrical Straight plug	F-3, F-22
MS90556C32413P	5935-01-086-6421	Connector, electrical Straight plug	F-1, F-2, F-21

PART NO.	NSN	DESCRIPTION	FIGURE NO.
MS90557C32405S	5935-01-257-4027	Connector, electrical Receptacle	F-2, F-22
MS90557C32413S	5935-01-087-0187	Connector, electrical Receptacle	F-1, F-2, F-17, F-21
MS90557C44413S	5935-01-091-9166	Connector, electrical Receptacle	F-16, F-20
MS90557C52413S	5935-01-106-4513	Connector, electrical Receptacle	F-15, F-19
MS9055844413P	5935-01-092-4269	Connector, electrical Receptacle	F-6, F-27
MS90558C32405P	5935-01-257-4037	Connector, electrical Receptacle	F-10, F-31
MS90558C32413P	5935-01-076-5738	Connector, electrical Receptacle	F-8, F-29
MS90558C52413P	5935-01-087-0780	Connector, electrical Receptacle	F-5, F-26
MS90563-3C	5935-00-114-8061	Cover, electrical Connector	F-9, F-11, F-30, F-32
MS90563-7C		Cover, Electrical connector	F-7, F-28
MS90564-11C		Cover, Electrical connector	F-5, F-26
MS90564-3C		Cover, Electrical Connector	F-8, F-10, F-29, F-31
MS90564-7C		Cover, Electrical connector	F-6, F-27

MANUFACTURED ITEMS and ILLUSTRATIONS

WARNING

High voltage is present in this system. DISE and PDISE support equipment using 120/208 VAC. Do not rely on the color of the wire insulation for phase color-coding. The insulation on the wires inside the cable jacket may vary, depending on the supplier. Wires will be marked with colored tape to designate the phases. Perform a continuity test to verify correct phase designation in accordance with the colored tape.

NOTE

See WP 0029, 0030, and 0031 for valuable information regarding applicable cable and connectors. The callout numbers in the illustration are applicable to the appropriate numbers in each legend given.

F-1 (Service/Feeder Cable Assembly, 40/60-Amp, (25 ft)

Component Legend for Figure F-1

1. MS90556C32413P CONNECTOR, ELECTRICAL STRAIGHT PLUG (P1)
2. M39029/48-320 CONTACT, ELECTRICAL PIN (P1-A, B, C)
3. M39029/48-321 CONTACT, ELECTRICAL PIN (P1-N)
4. M39029/48-318 CONTACT, ELECTRICAL PIN (P1-G)
5. MS3348-6-8L REDUCER, ELECTRICAL CONTACT (P1-G, P2-G)
6. M23053/5-112-4 SLEEVING, INSULATION, HEAT SHRINK
7. CO-04HDF (4/4-4/12R) 1290 CABLE
8. MS90557C32413S CONNECTOR, ELECTRICAL RECEPTACLE (P2)
9. M39029/49-331 CONTACT, ELECTRICAL SOCKET (P2-A, B, C, N)
10. M39029/49-329 CONTACT, ELECTRICAL SOCKET (P2-G)
11. TAG, WARNING

- a. Cut and remove 3 1/2' of cable and 7/8' of wire insulation from cables as indicated. (WP 0029)
- b. Twist four ground wires together.
- c. Install P1 and P2 connectors on proper cable ends so colors and pins/sockets match as Indicated in Table 2:

Table 2. Service/Feeder Cable Assembly, 40/60-Amp, (25 ft)

COLOR	FROM	TO
BLACK	P1-A	P2-A
RED	P1-B	P2-B
BLUE	P1-C	P2-C
WHITE	P1-N	P2-N
GREEN (OR BARE) GREEN (OR BARE) GREEN (OR BARE) GREEN (OR BARE)	P1-G	P2-G

- d. Verify electrical continuity for each "From-To" path with multi-meter.
- e. Crimp pins/sockets to cable wires.
- f. Assemble P1 and P2 connectors so keys/keyways and pins/sockets align as indicated.
- g. Mark sleeves in accordance with MIL-M-60903 as follows:

- 97403-13226E7023-3
- 120/208 VAC
- 3 PHASE
- 60 AMP

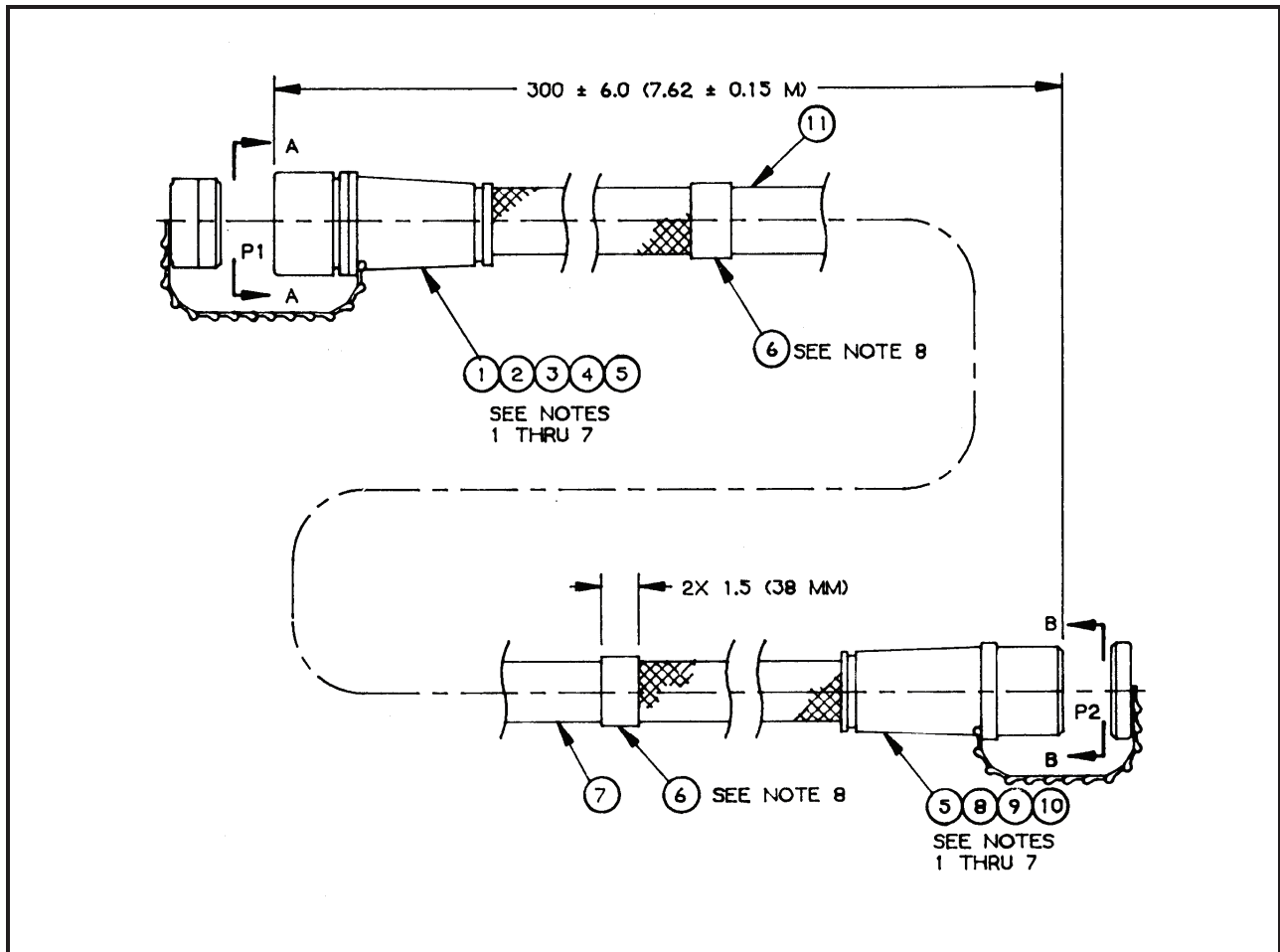

Figure F-1. Service/Feeder Cable Assembly, 40/60-Amp, (25 ft) (1 of 2)

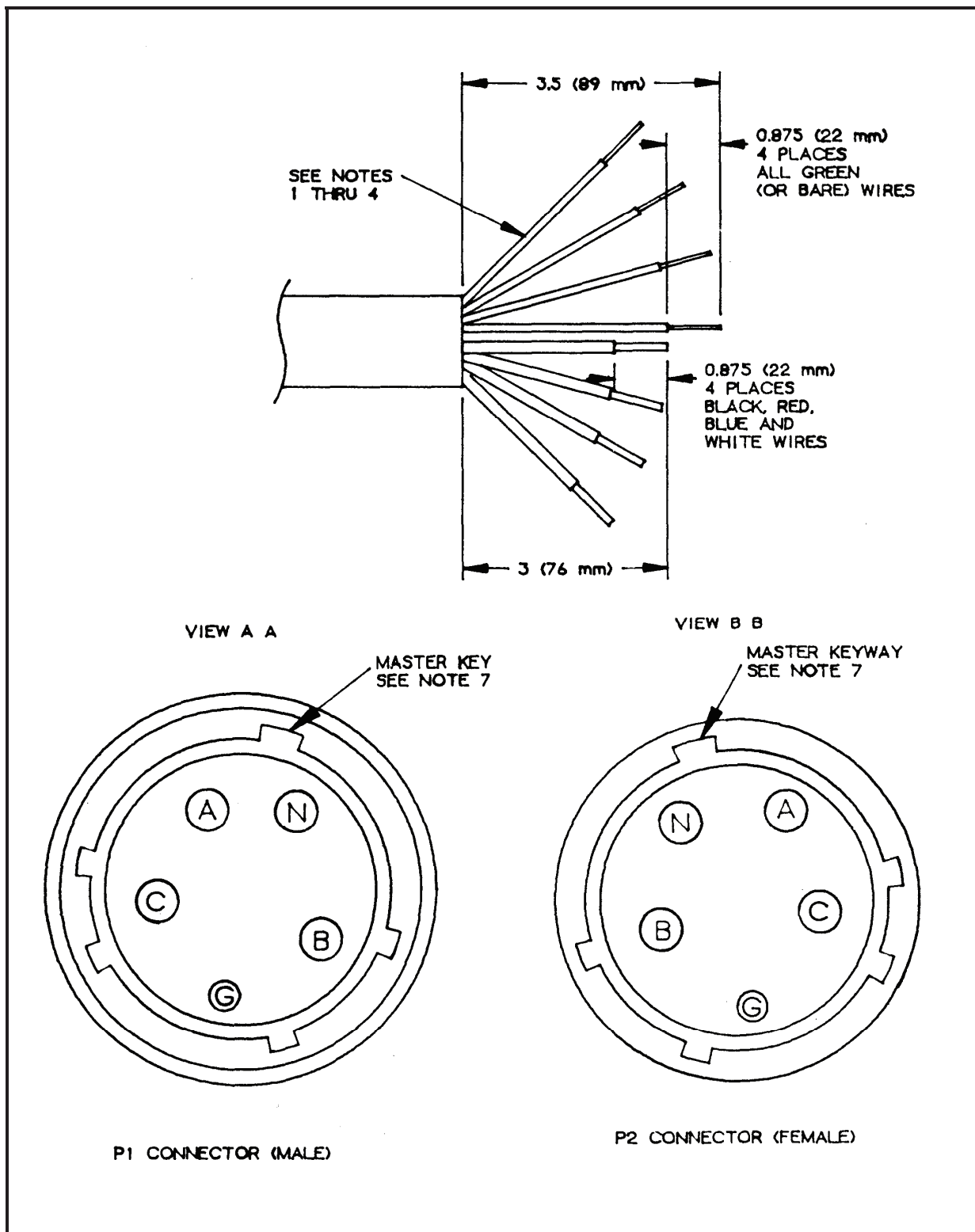

Figure F-1. Service/Feeder Cable Assembly, 40/60-Amp, (25 ft) (2 of 2)

WARNING

High voltage is present in this system. DISE and PDISE support equipment using 120/208 VAC. Do not rely on the color of the wire insulation for phase color-coding. The insulation on the wires inside the cable jacket may vary, depending on the supplier. Wires will be marked with colored tape to designate the phases. Perform a continuity test to verify correct phase designation in accordance with the colored tape.

NOTE

See WP 0029, 0030, and 0031 for valuable information regarding applicable cable and connector information. The callout numbers in the illustration are applicable to the appropriate number in each legend given.

F-2 (Service/Feeder Cable Assembly, 40/60-Amp, (100 ft)

Component Legend for Figure F-2

1. MS90556C32413P CONNECTOR, ELECTRICAL STRAIGHT PLUG (P1)
2. M39029/48-320 CONTACT, ELECTRICAL PIN (P1-A, B, C)
3. M39029/48-321 CONTACT, ELECTRICAL PIN (P1-N)
4. M39029/48-318 CONTACT, ELECTRICAL PIN (P1-G)
5. MS3348-6-8L REDUCER, ELECTRICAL CONTACT (P1-G, P2-G)
6. M23053/5-112-4 SLEEVING, INSULATION, HEAT SHRINK
7. CO-04HDF (4/4-4/12R) 1290 CABLE
8. MS90557C32413S CONNECTOR, ELECTRICAL RECEPTACLE (P2)
9. M39029/49-331 CONTACT, ELECTRICAL SOCKET (P2-A, B, C, N)
10. M39029/49-329 CONTACT, ELECTRICAL SOCKET (P2-G)
11. TAG, WARNING

- a. Cut and remove 3 1/2' of cable and 7/8' of wire insulation from cables as indicated. (WP 0029)
- b. Twist four ground wires together.
- c. Install P1 and P2 connectors on proper cable ends so colors and pins/sockets match as indicated in Table 3:

Table 3. Service/Feeder Cable Assembly, 40/60-Amp, (100 ft)

COLOR	FROM	TO
BLACK	P1-A	P2-A
RED	P1-B	P2-B
BLUE	P1-C	P2-C
WHITE	P1-N	P2-N
GREEN (OR BARE) GREEN (OR BARE) GREEN (OR BARE) GREEN (OR BARE)	P1-G	P2-G

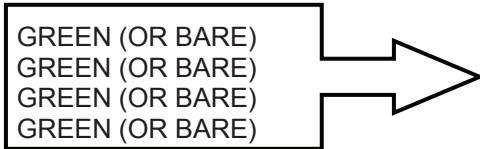

- d. Verify electrical continuity for each "From-To" path with multi-meter.
- e. Crimp pins/sockets to cable wires.
- f. Assemble P1 and P2 connectors so keys/keyways and pins/sockets align as indicated.
- g. Mark sleeves in accordance with MIL-M-60903 as follows:

- 97403-13226E7023-1
- 120/208 VAC
- 3 PHASE
- 60 AMP

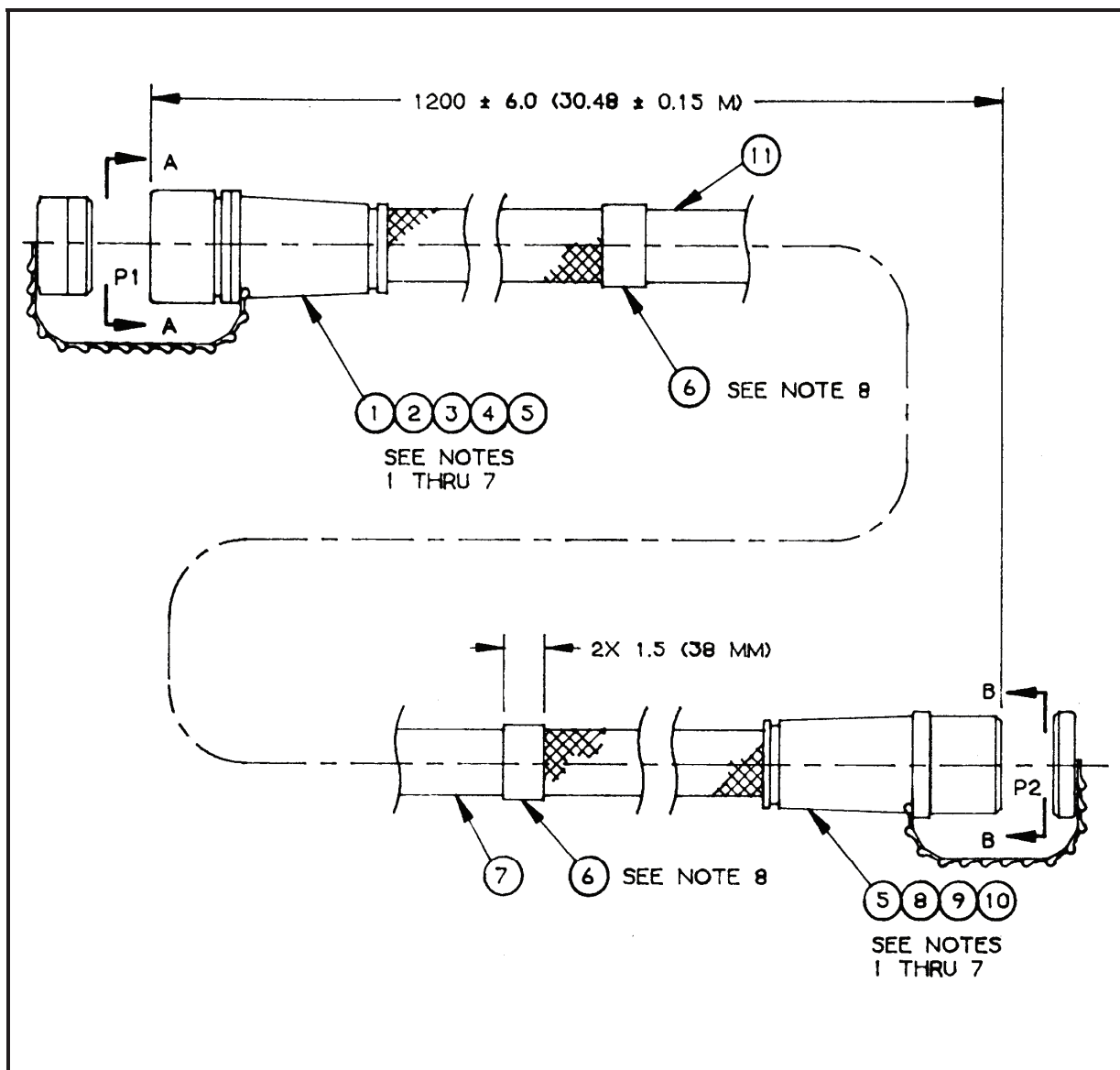

Figure F-2. Service/Feeder Cable Assembly, 40/60-Amp, (100 ft) (1 of 2)

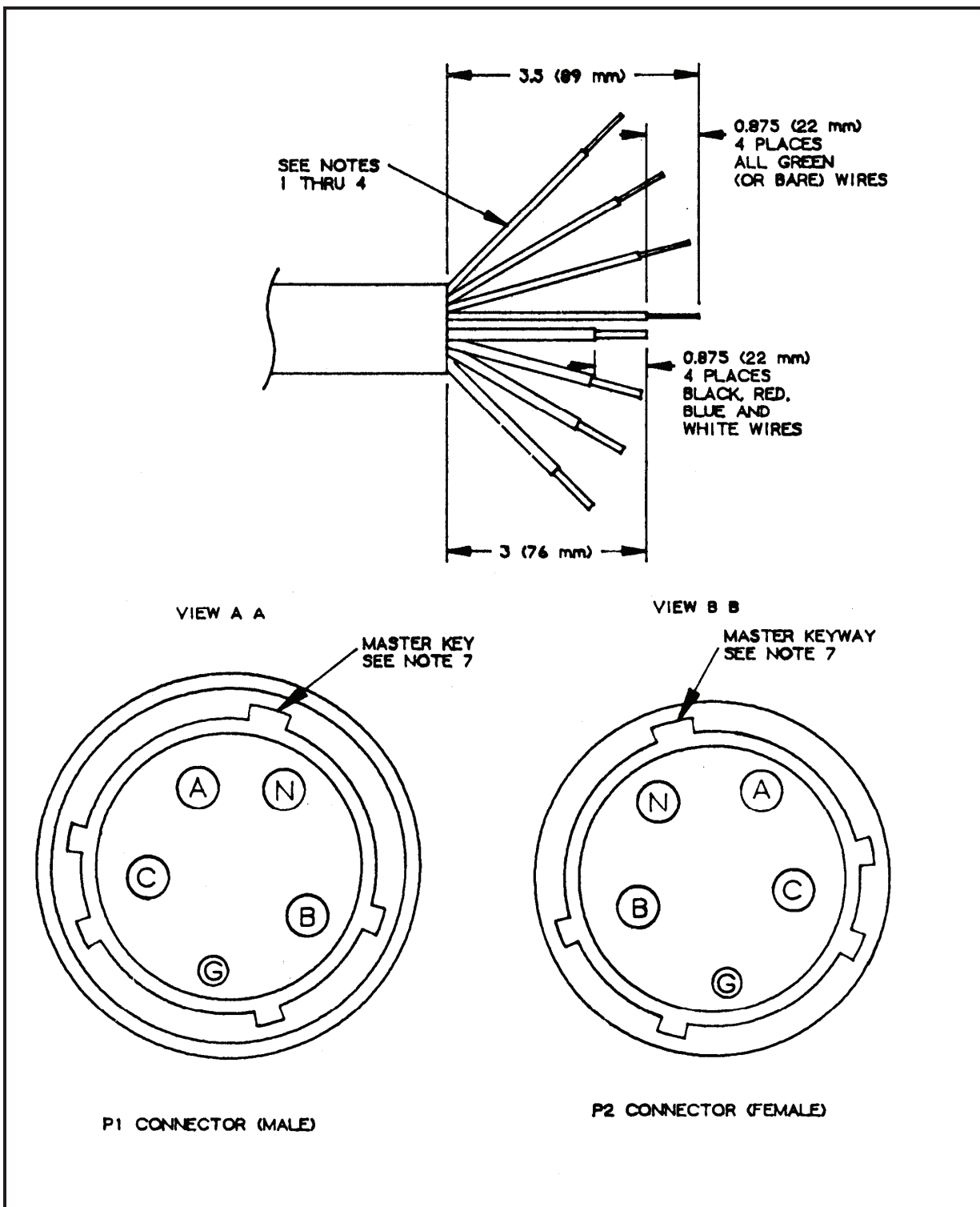

Figure F-2. Service/Feeder Cable Assembly, 40/60-Amp, (100 ft) (2 of 2)

WARNING

High voltage is present in this system. DISE and PDISE support equipment using 120/208 VAC. Do not rely on the color of the wire insulation for phase color-coding. The insulation on the wires inside the cable jacket may vary, depending on the supplier. Wires will be marked with colored tape to designate the phases. Perform a continuity test to verify correct phase designation in accordance with the colored tape.

NOTE

See WP 0029, 0030, and 0031 for valuable information regarding applicable cable and connector information. The callout numbers are applicable to the appropriate illustrations numbers given in each legend given.

F-3 (Service/Feeder Cable Assembly, 60-Amp, (50 ft)

Component Legend for Figure F-3

1. MS90556C32405P CONNECTOR, ELECTRICAL STRAIGHT PLUG (P1)
2. M39029/48-320 CONTACT, ELECTRICAL PIN (P1-A)
3. M39029/48-321 CONTACT, ELECTRICAL PIN (P1-N)
4. M39029/48-318 CONTACT, ELECTRICAL PIN (P1-G, G2)
5. MS3348-6-8L REDUCER, ELECTRICAL CONTACT (P1-G1, G)
6. M23053/5-112-4 SLEEVING, INSULATION, HEAT SHRINK
7. CO-02HDF (2/4-2/8R) 1290 CABLE
8. MS90557C32405S CONNECTOR, ELECTRICAL RECEPTACLE (P2)
9. M39029/49-331 CONTACT, ELECTRICAL SOCKET (P2-A, N)
10. M39029/49-329 CONTACT, ELECTRICAL SOCKET (P2-G1,G-2)
11. TAG, WARNING

- a. Cut and remove 3' of cable and 7/8' of wire insulation from cables as indicated. (WP 0029)
- b. Install P1 and P2 connectors on proper cable ends so colors and pins/sockets match as indicated in Table 4:

Table 4. Service/Feeder Cable Assembly, 60-Amp, (50 ft)

COLOR	FROM	TO
BLACK	P1-A	P2-A
WHITE	P1-N	P2-N
GREEN (OR BARE)	P1-G	P2-G1
GREEN (OR BARE)	P1-G2	P2-G2

- c. Verify electrical continuity for each "From-To" path with multi-meter.
- d. Crimp pins/sockets to cable wires.
- e. Assemble P1 and P2 connectors so keys/keyways and pins/sockets align as indicated.

f. Mark sleeves in accordance with MIL-M-60903 as follows:

- 97403-13226E7022-2
- 120/208 VAC
- 3 PHASE
- 60 AMP

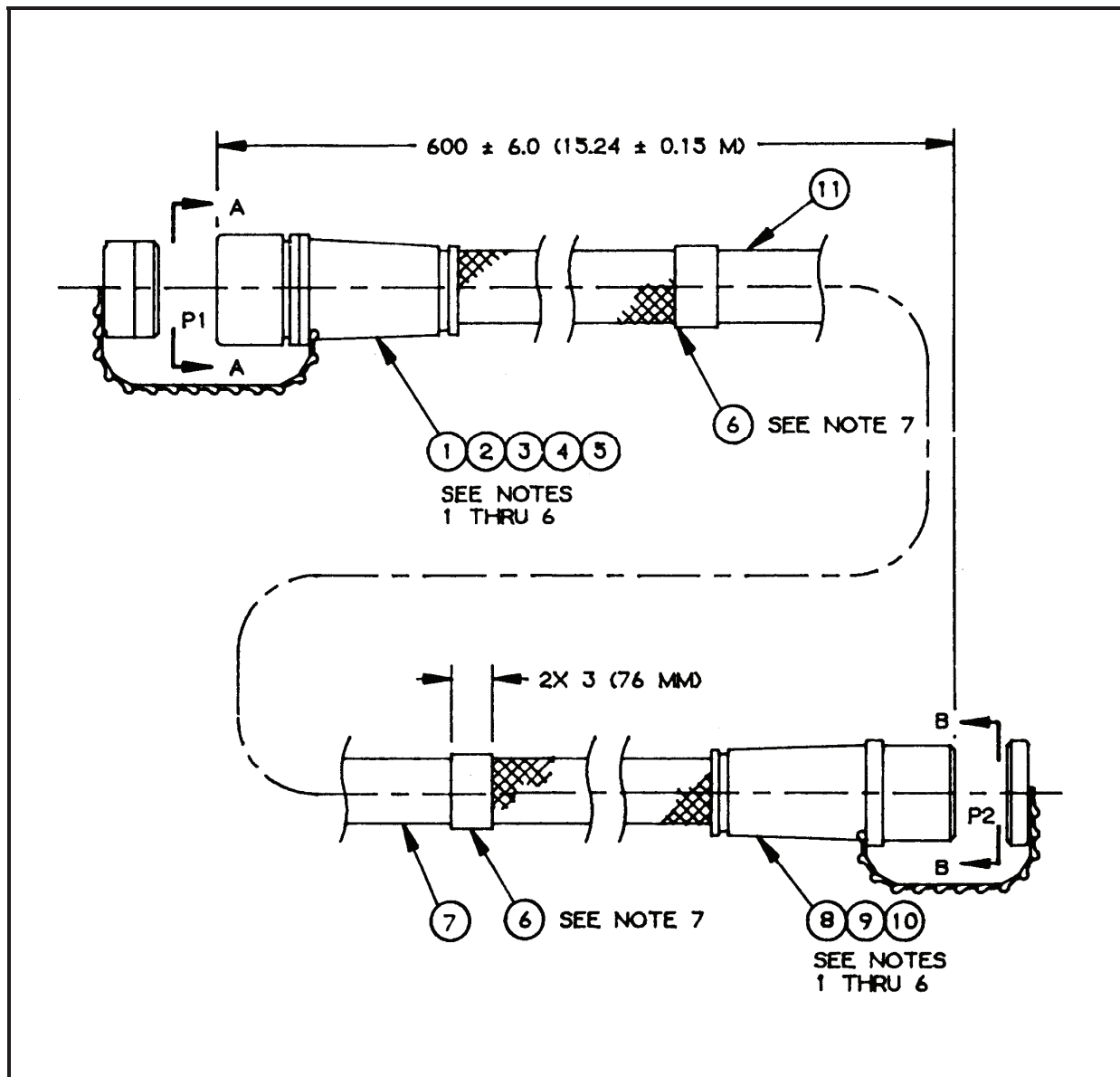

Figure F-3. Service/Feeder Cable Assembly, 60-Amp, (50 ft) (1 of 2)

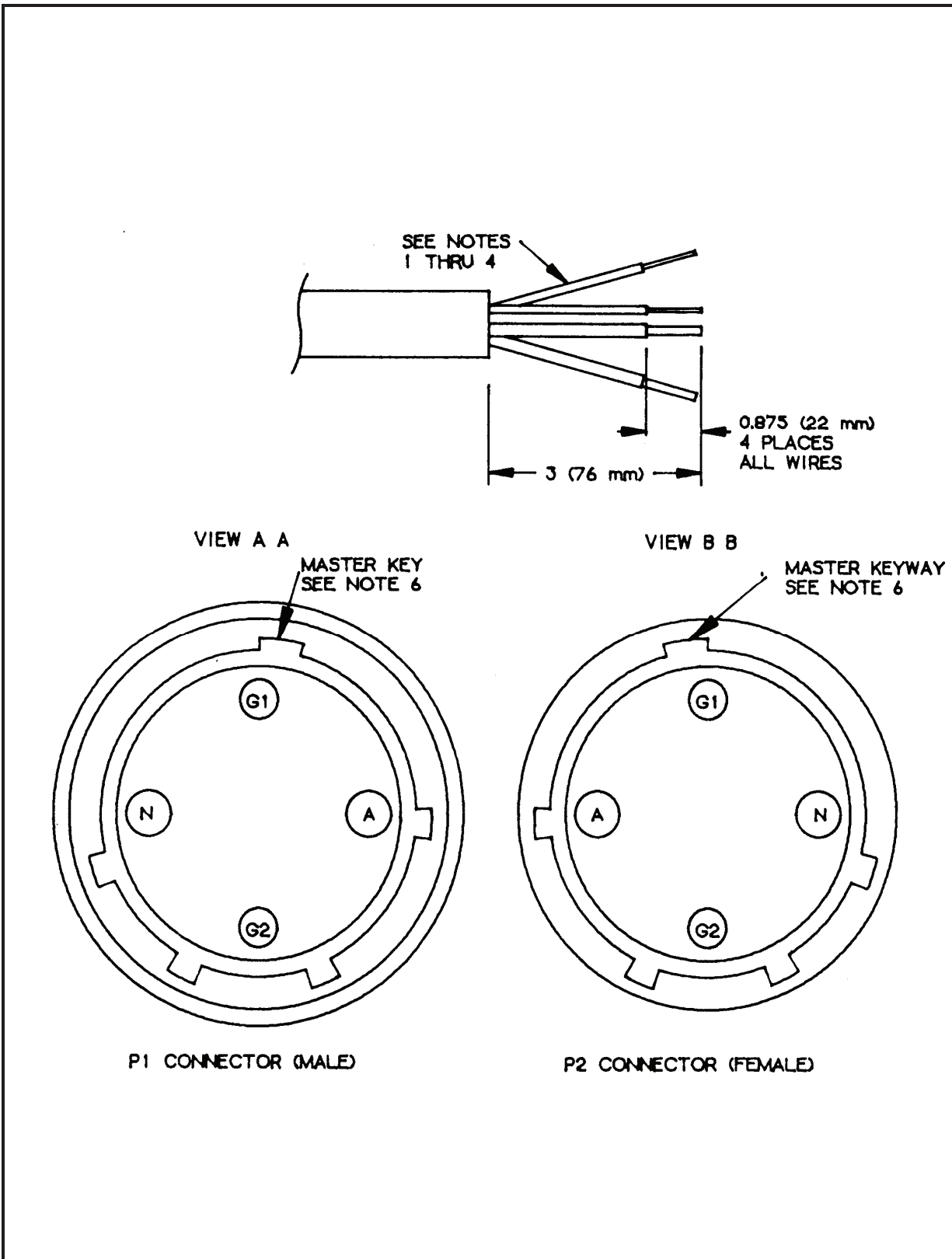

Figure F-3. Service/Feeder Cable Assembly, 60-Amp, (50 ft) (2 of 2)

WARNING

High voltage is present in this system. DISE and PDISE support equipment using 120/208 VAC. Do not rely on the color of the wire insulation for phase color-coding. The insulation on the wires inside the cable jacket may vary, depending on the supplier. Wires will be marked with colored tape to designate the phases. Perform a continuity test to verify correct phase designation in accordance with the colored tape.

NOTE

See WP 0029, 0030, and 0031 for valuable information regarding applicable cable and Connector information. The callout numbers are considered Notes applicable to the appropriate number in each legend given.

F-4 (Extension Cable Assembly, 20-Amp, (3.5 ft)

Component Legend for Figure F-4

1. MS3456W16-10P CONNECTOR, ELECTRICAL STRAIGHT PLUG (P1)
2. M39029/44-290 CONTACT, ELECTRICAL PIN (P1-A, B, C)
3. MS25042-16D COVER, ELECTRICAL CONNECTOR, STRAIGHT PLUG
4. CO-03MGF (3/12) 0385 CABLE, BLACK
5. M23053/5-109-4 SLEEVING, INSULATION, HEAT SHRINK
6. MS3451W16-10S CONNECTOR, ELECTRICAL, RECEPTACLE (P2)
7. MS25043-16D COVER, ELECTRICAL, CONNECTOR, ELECTRICAL RECEPTACLE
8. M39029/30-219 CONTACT, ELECTRICAL SOCKET (P2-A, B, C)

- a. Cut and remove ½ of cable and 3/8' of wire insulation from cables as indicated. (WP 0029)
- b. Install P1 and P2 connectors on proper cable ends so colors and pins/sockets match as indicated in Table 5:

Table 5. Extension Cable Assembly, 20-Amp, (3.5 ft)

COLOR	FROM	TO
BLACK	P1-A	P2-A
WHITE	P1-N	P2-N
GREEN (OR BARE)	P1-C	P2-C

- c. Verify electrical continuity for each “From-To” path with multi-meter.
- d. Crimp pins/sockets to cable wires.
- e. Assemble P1 and P2 connectors so keys/keyways and pins/sockets align as indicated.

f. Mark sleeves in accordance with MIL-M-60903 as follows:

- 97403-13226E7032-4
- 120 VAC
- Single PHASE
- 20 AMP

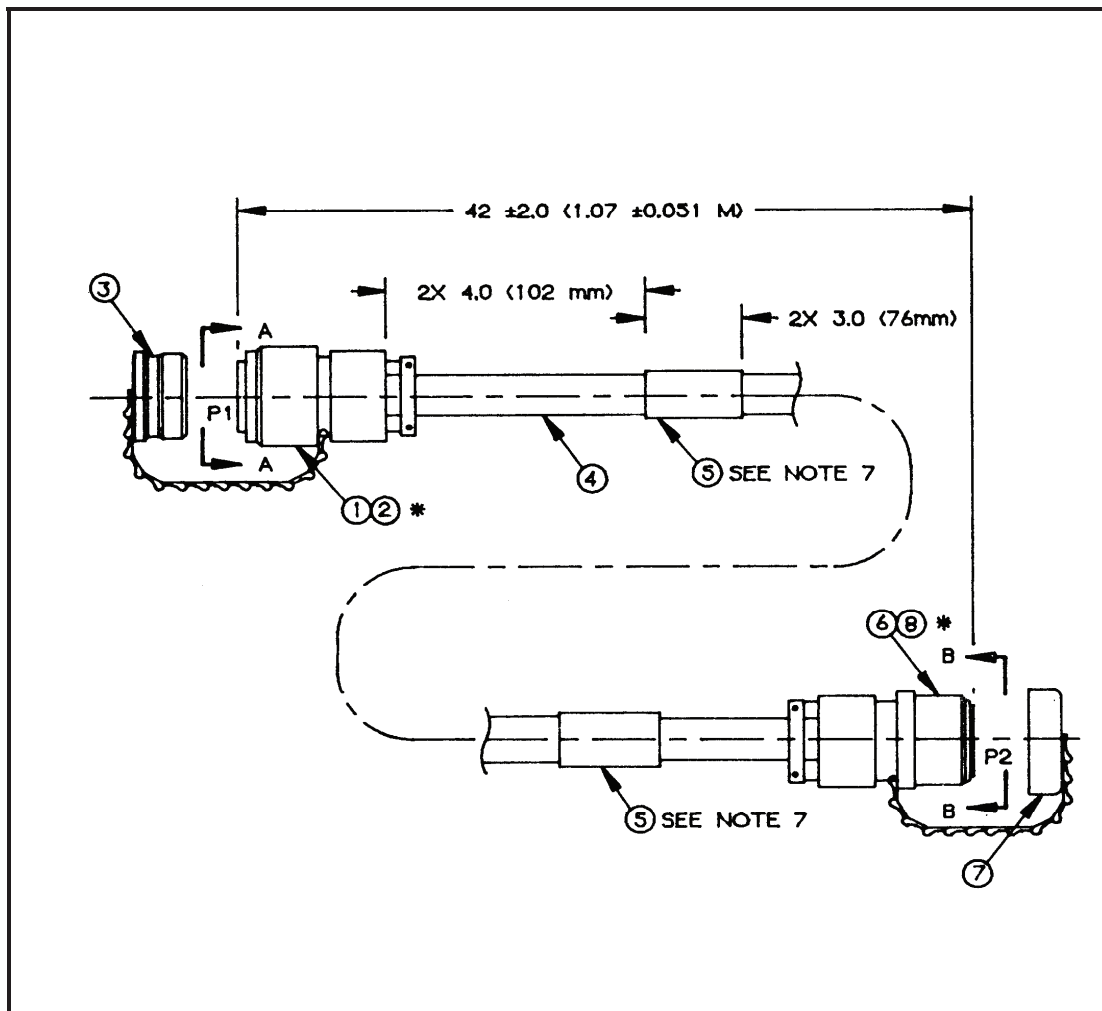

Figure F-4. Extension Cable Assembly, 20-Amp, (3.5 ft) (1 of 2)

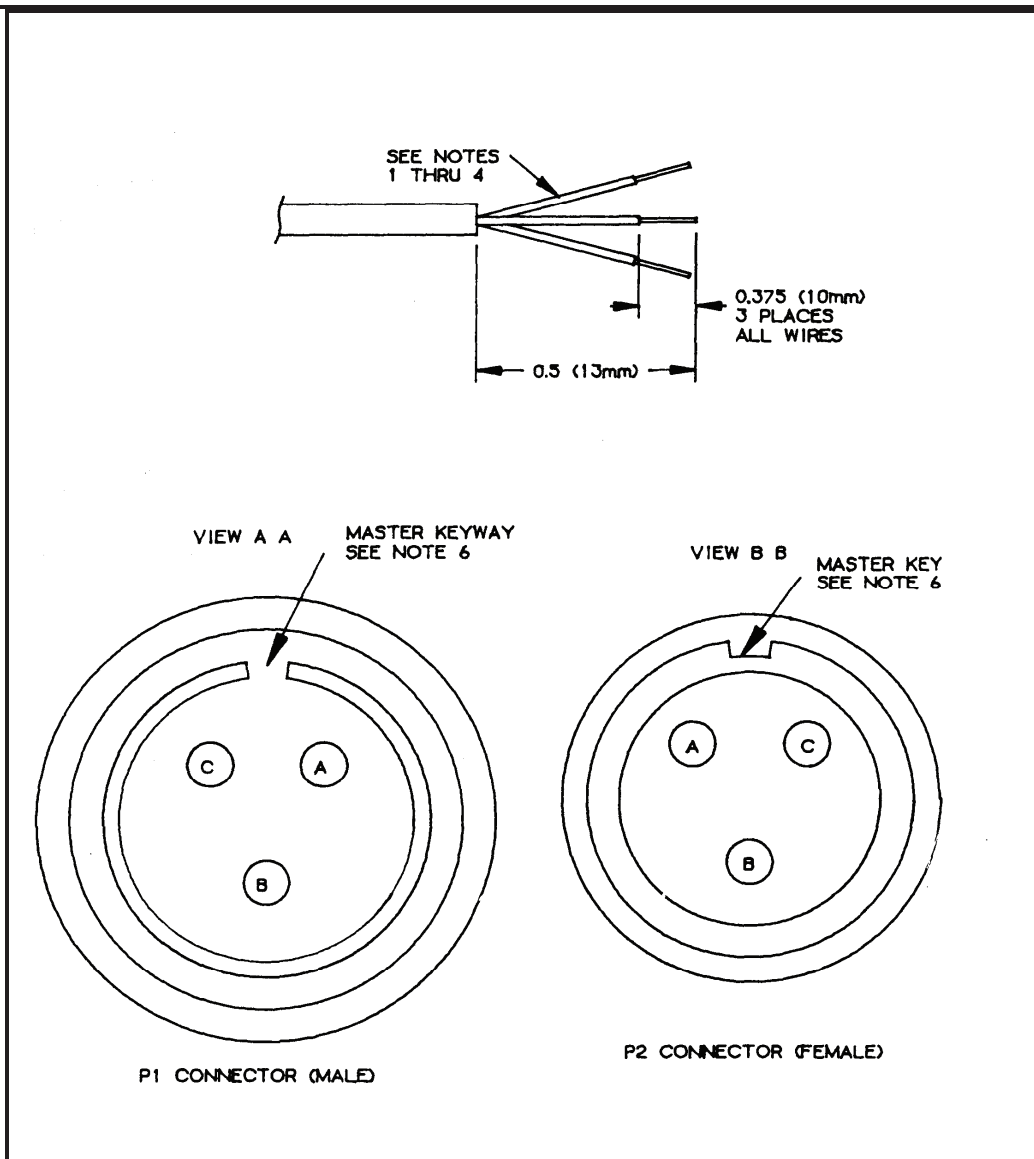

Figure F-4. Extension Cable Assembly, 20-Amp, (3.5 ft) (2 of 2)

NOTE

See WP 0029, 0030, and 0031 for valuable information regarding applicable cable and connectors. The callout numbers are applicable to the appropriate illustration number in each legend given.

F-5 (Feeder Center Input Connector Assembly, 200-Amp (J1))

Component Legend for Figure F-5

1. MS90564-11C COVER, ELECTRICAL CONNECTOR
2. MS90558C52413P CONNECTOR, ELECTRICAL
3. GASKET
4. M39029/48-327 CONTACT, ELECTRICAL PIN (A, B, C)
5. M39029/48-328 CONTACT, ELECTRICAL PIN (N)
6. M5086/2-02-9 WIRE, ELECTRICAL (A, B, C, N)
7. M5086/2-4-9 WIRE, ELECTRICAL (G1, G2, G3, G4)
8. M39029/48-322 CONTACT, ELECTRICAL PIN (G1, G2, G3, G4)
9. MS3349 REDUCER, CONTACT ELECTRICAL (G1, G2, G3, G4)

- a. Cut and remove 4 1/6' of wire insulation as indicated. (WP 0029)
- b. Crimp electrical contact pins to wires for positions as noted in Table 6 below:

Table 6. Feeder Center Input Connector Assembly, 200-Amp (J1)

POSITION	FIGURE ITEM NO.	WIRE SIZE	WIRE LENGTH
A	4 and 6	2/0	16 (406.4 MM)
B	4 and 6	2/0	16 (406.4 MM)
C	4 and 6	2/0	16 (406.4 MM)
N	5 and 6	2/0	16 (406.4 MM)
G1	7, 8, and 9	4	16 (406.4 MM)
G2	7, 8, and 9	4	16 (406.4 MM)
G3	7, 8, and 9	4	16 (406.4 MM)
G4	7, 8, and 9	4	16 (406.4 MM)

- c. Electrical connector (Figure F-5, Item 2) is furnished with the following:
 - Cover (Item 1)
 - Gasket (Item 3)
 - Electrical contact pins (Items 4, 5, and 8)
- d. Assemble connector so keys/keyways and pins align as indicated.

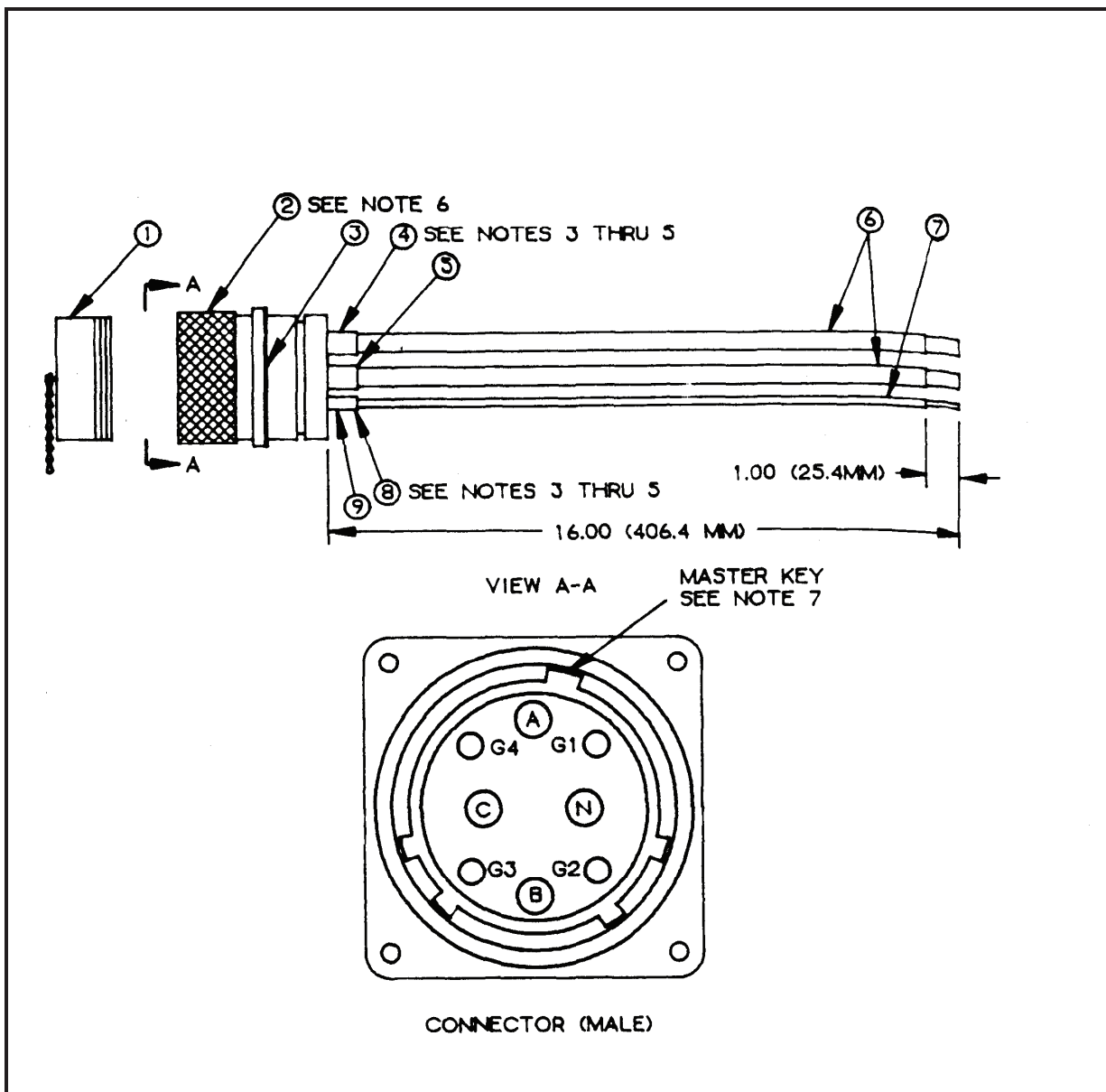

Figure F-5. Feeder Center Input Connector Assembly, 200-Amp (J1)

NOTE

See WP 0029, 0030, and 0031 for valuable information regarding applicable cable and connectors. The callout numbers are considered applicable to the appropriate illustration number in each legend given.

F-6 (Feeder Center Input Connector, 100-Amp (J1))

Component Legend for Figure F-6

1. MS90564-7C COVER, ELECTRICAL CONNECTOR
2. MS9055844413P CONNECTOR, ELECTRICAL
3. GASKET
4. M39029/48-323 CONTACT, ELECTRICAL PIN (A, B, C)
5. M39029/48-324 CONTACT, ELECTRICAL PIN (N)
6. M5086/2-I-9 WIRE, ELECTRICAL (A, B, C, N)
7. M5086/2-8-9 WIRE, ELECTRICAL (G1, G2, G3, G4)
8. M39029/48-319 CONTACT, ELECTRICAL PIN (G1, G2, G3, G4)
9. MS3348-6-8L REDUCER, CONTACT PIN (G1, G2, G3, G4)

- a. Cut and remove 3 ½' of wire insulation as indicated. (WP 0029)
- b. Crimp electrical contact pins to wires for positions as noted in Table 7 below:

Table 7. Feeder Center Input Connector, 100-Amp (J1)

POSITION	FIGURE ITEM NO.	WIRE SIZE	WIRE LENGTH
A	4 and 6	1	14 (355.6 MM)
B	4 and 6	1	14 (355.6 MM)
C	4 and 6	1	14 (355.6 MM)
N	5 and 6	1	14 (355.6 MM)
G1	7, 8, and 9	8	14 (355.6 MM)
G2	7, 8, and 9	8	14 (355.6 MM)
G3	7, 8, and 9	8	14 (355.6 MM)
G4	7, 8, and 9	8	14 (355.6 MM)

- c. Electrical connector (Figure F-6, Item 2) is furnished with the following:

- Cover (Item 1)
- Gasket (Item 3)
- Electrical contact pins (Items 4, 5, and 8)

- d. Assemble connector so keys/keyways and pins align as indicated.

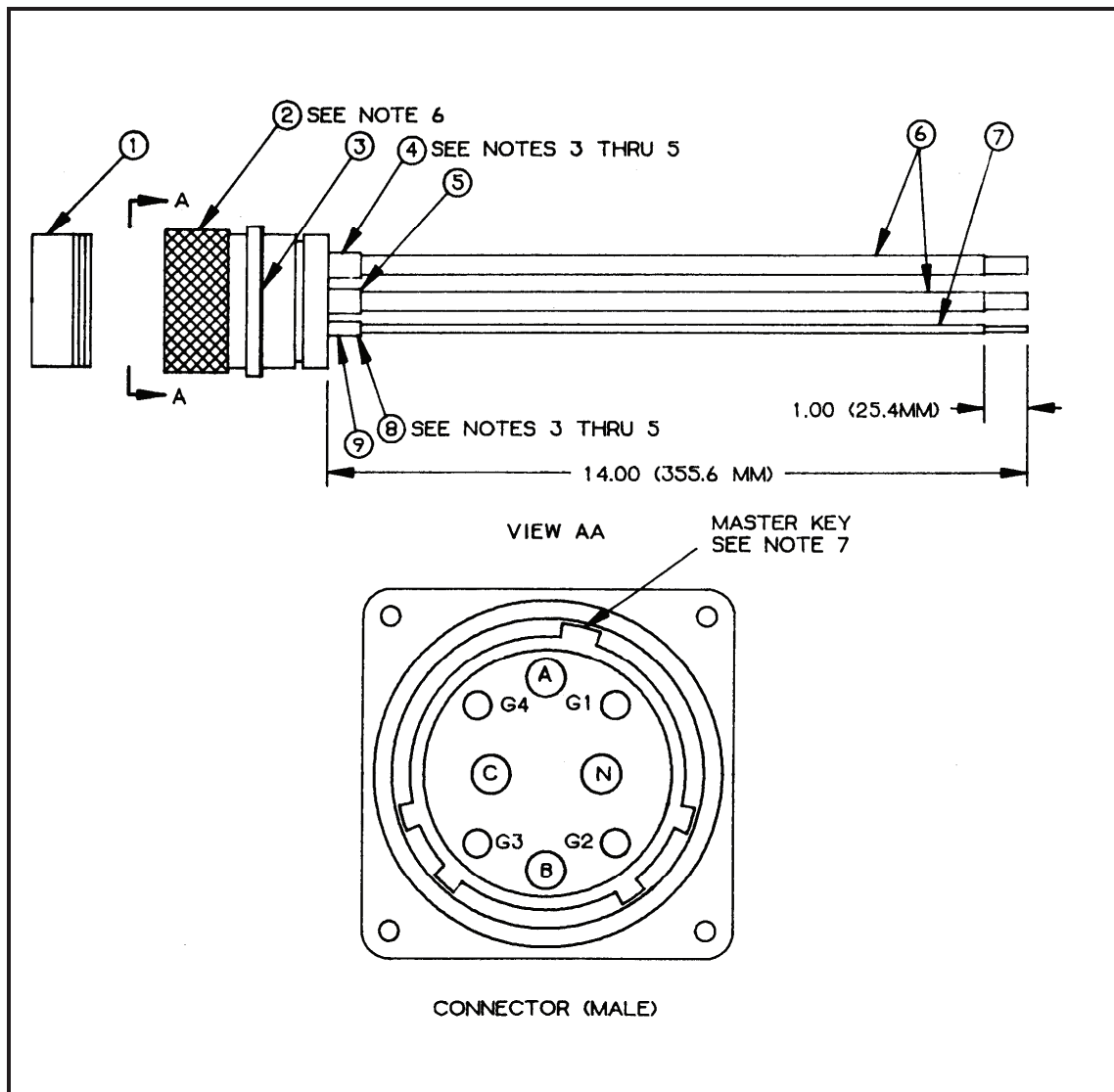

Figure F-6. Feeder Center Input Connector, 100-Amp (J1)

NOTE

See WP 0029, 0030, and 0031 for valuable information regarding applicable cable and connectors. The callout numbers are considered Notes applicable to the appropriate number in each legend given.

**F-7 (Feeder Center Output Connectors, M200, 100-Amp (J4, J5, J11)
(Feeder Center Output Connector, M100, 100-Amp (J2))**

Component Legend for Figure F-7

1. MS90563-7C COVER, ELECTRICAL CONNECTOR
2. MS9055C44413S CONNECTOR, ELECTRICAL RECEPTACLE
3. GASKET
4. M39029/49-333 CONTACT, ELECTRICAL SOCKET (A, B, C, N)
5. M5086/2-1-9 WIRE, ELECTRICAL (A, B, C, N)
6. M5086/2-8-9 WIRE, ELECTRICAL (G1, G2, G3, G4)
7. M39029/49-330 CONTACT, ELECTRICAL SOCKET (G1, G2, G3, G4)
8. MS3348-6-8L REDUCER, ELECTRICAL CONTACT (G1, G2, G3, G4)

- a. Cut and remove 3 1/2' of wire insulation as indicated. (WP 0029)
- b. Crimp electrical contact pins to wires for positions as noted in Table 8 below:

Table 8. Feeder Center Output Connector Assemblies, M200/100, 100-Amp

POSITION	FIGURE ITEM NO.	WIRE SIZE	WIRE LENGTH
A	4 and 6	1	14 (355.6 MM)
B	4 and 6	1	14 (355.6 MM)
C	4 and 6	1	14 (355.6 MM)
N	5 and 6	1	14 (355.6 MM)
G1	7, 8, and 9	8	14 (355.6 MM)
G2	7, 8, and 9	8	14 (355.6 MM)
G3	7, 8, and 9	8	14 (355.6 MM)
G4	7, 8, and 9	8	14 (355.6 MM)

- c. Electrical connector (Figure F-7, Item 2) is furnished with the following:
 - Cover (Item 1)
 - Gasket (Item 3)
 - Electrical contact pins (Items 4 and 7)
- d. Assemble connector so keys/keyways and pins align as indicated.

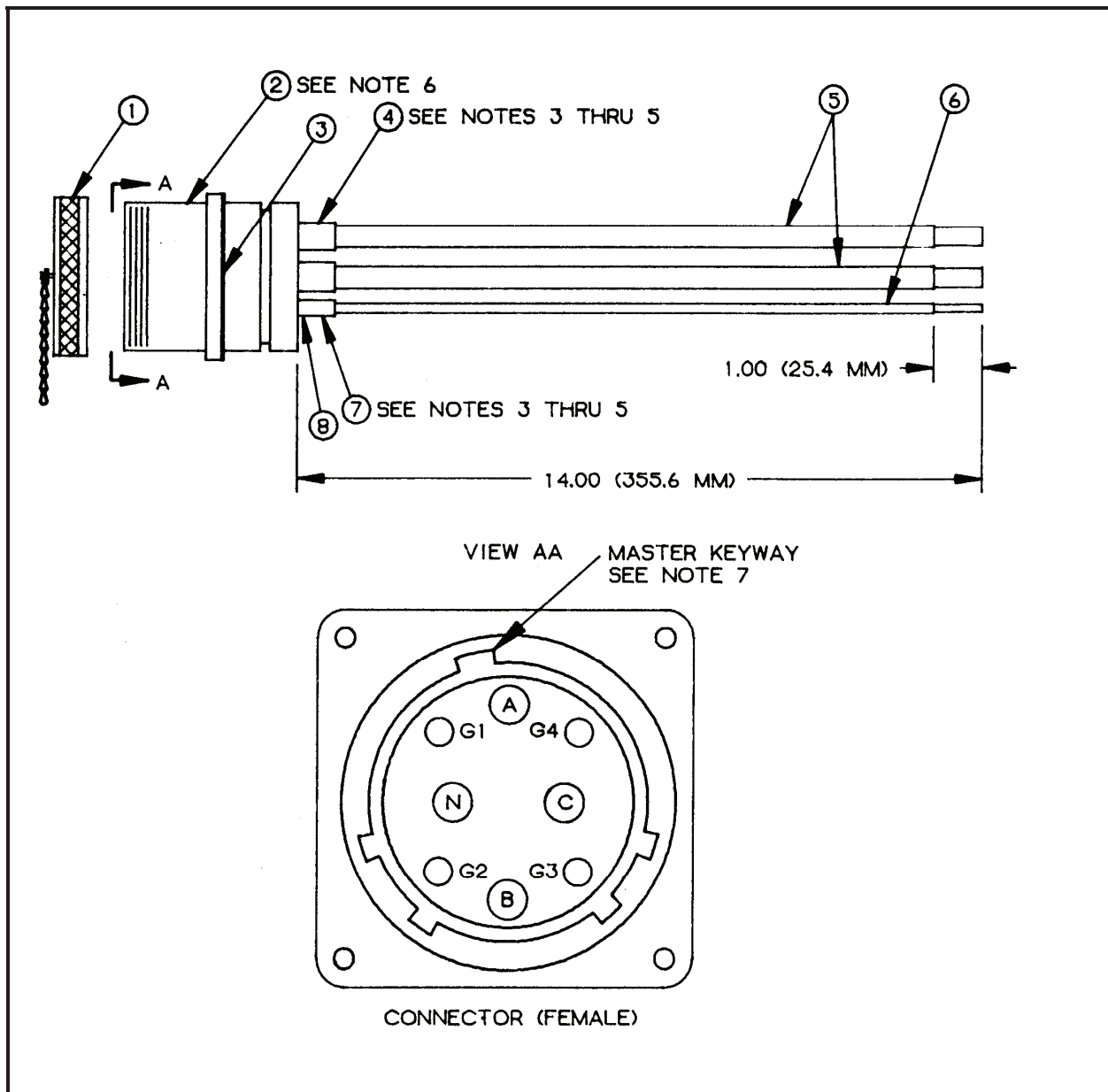

Figure F-7. Feeder Center Output Connector Assemblies, M200/100, 100-Amp

NOTE

See WP 0029, 0030, and 0031 for valuable information regarding applicable cable and connectors. The callout numbers are considered applicable to the appropriate illustration number in each legend given.

F-8 (Distribution Center Input Connector Assembly, M40, 40-Amp (J1))

Component Legend for Figure F-8

1. MS90564-3C COVER, ELECTRICAL CONNECTOR
2. MS90558C32413P CONNECTOR, ELECTRICAL
3. GASKET
4. M39029/48-320 CONTACT, ELECTRICAL PIN (A, B, C)
5. M39029/48-321 CONTACT, ELECTRICAL PIN (N)
6. M5086/2-4-9 WIRE, ELECTRICAL (A, B, C, N)
7. M5086/2-8-9 WIRE, ELECTRICAL (G)
8. M39029/48-318 CONTACT, ELECTRICAL PIN (G)
9. MS3348-6-8L REDUCER, ELECTRICAL CONTACT (G)

- a. Cut and remove 3 ½' of wire insulation as indicated. (WP 0029)
- b. Crimp electrical contact pins to wires for positions as noted in Table 9 below:

Table 9. Distribution Center Input Connector Assembly, M40, 40-Amp (J1)

POSITION	FIGURE ITEM NO.	WIRE SIZE	WIRE LENGTH
A	4 and 5	3	14 (355.6 MM)
B	4 and 5	3	14 (355.6 MM)
C	4 and 5	3	14 (355.6 MM)
N	5 and 8	3	14 (355.6 MM)
G	6, 7, and 9	4	14 (355.6 MM)

- c. Electrical connector (Figure F-8, Item 2) is furnished with the following:
 - Cover (Item 1)
 - Gasket (Item 3)
 - Electrical contact pins (Items 4, 7, and 8)
- d. Assemble connector so keys/keyways and pins align as indicated.

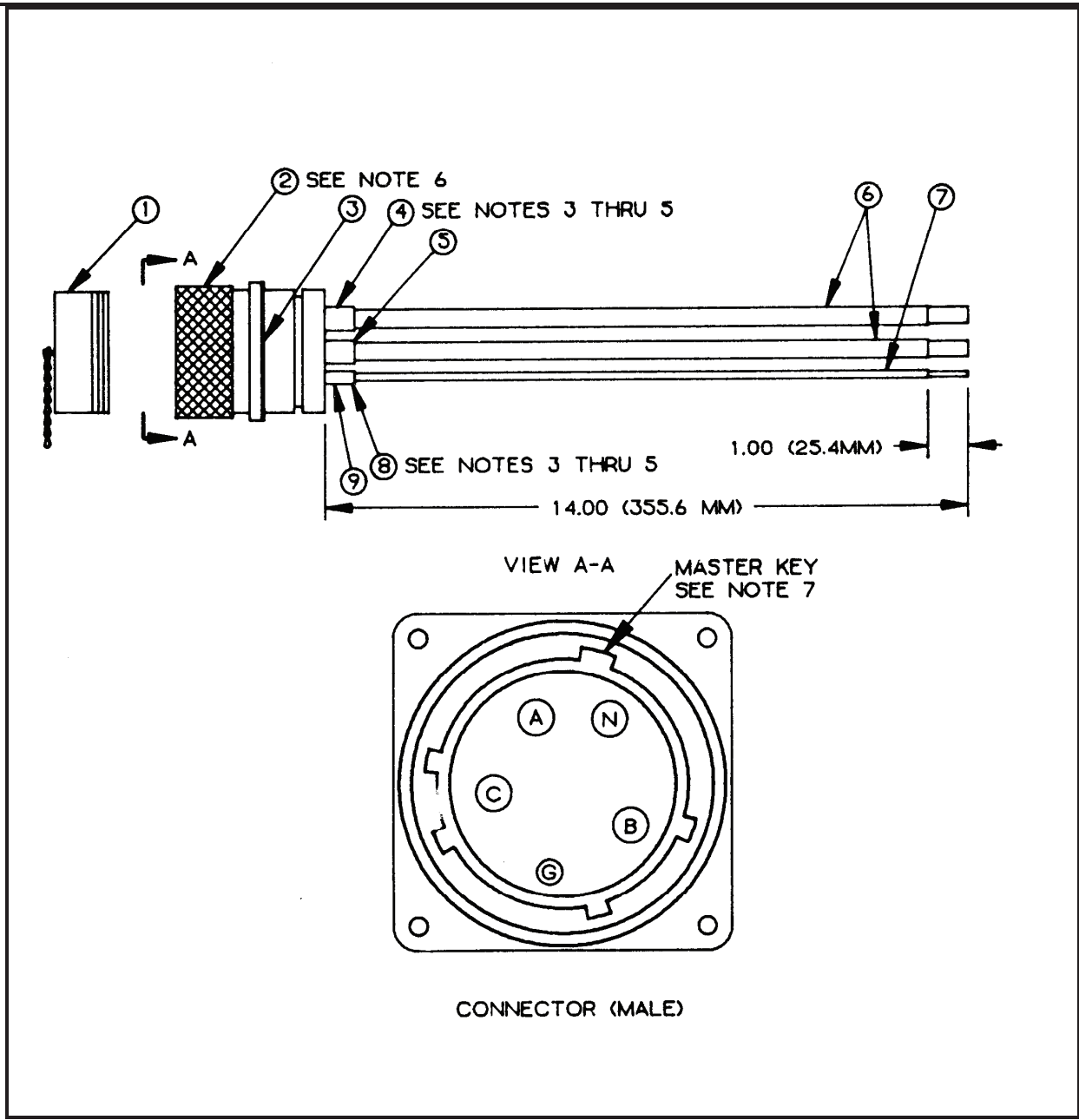

Figure F-8. Distribution Center Input Connector Assembly, M40, 40-Amp (J1)

NOTE

See WP 0029, 0030, and 0031 for valuable information regarding applicable cable and connectors. The callout numbers are considered applicable to the appropriate illustration number in each legend given.

**F-9 (Feeder Center Output Connector Assemblies, M200, 40/60-Amp (J7, J8, J9, J10)
 (Feeder Center Output Connector Assemblies, M100, 40/60-Amp (J3, J4, J5, J6)
 (Distribution Center Output Connector Assembly, M40, 40/60-Amp (J2)**

Component Legend for Figure F-9

1. MS90564-3C COVER, ELECTRICAL CONNECTOR
2. MS90558C32413S CONNECTOR, ELECTRICAL RECEPTACLE
3. GASKET
4. M39029/49-331 CONTACT, ELECTRICAL PIN (A, B, C, N)
5. M5086/2-4-9 WIRE, ELECTRICAL (A, B, C, N)
6. M5086/2-8-9 WIRE, ELECTRICAL (G)
7. M39029/49-329 CONTACT, ELECTRICAL SOCKET (G)
8. MS3348-6-8L REDUCER, ELECTRICAL CONTACT (G)

- a. Cut and remove 3 ½ ' of wire insulation as indicated. (WP 0029)
- b. Crimp electrical contact pins to wires for positions as noted in Table 10 below:

Table 10. Output Connector Assemblies, 40/60-Amp

POSITION	ITEM NO.	WIRE SIZE	WIRE LENGTH
A	4 and 5	4	14 (355.6 MM)
B	4 and 5	4	14 (355.6 MM)
C	4 and 5	4	14 (355.6 MM)
N	4 and 5	4	14 (355.6 MM)
G	6, 7, and 8	8	14 (355.6 MM)

c. Electrical connector (Figure F-9, Item 2) is furnished with the following:

- Cover (Item 1)
- Gasket (Item 3)
- Electrical contact pins (Items 4 and 7,)

d. Assemble connector so keys/keyways and pins align as indicated.

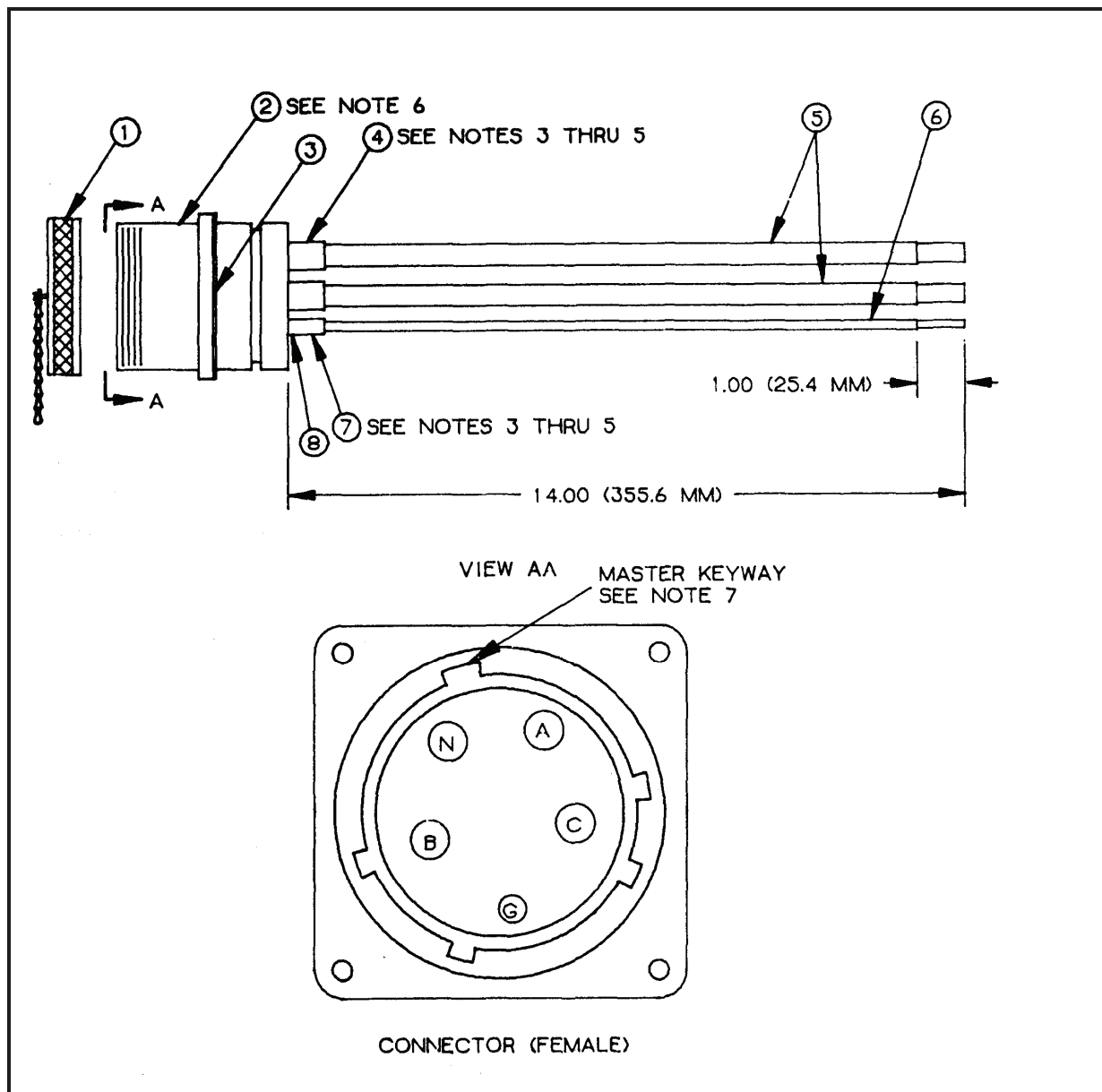

Figure F-9. Output Connector Assemblies, 40/60-Amp.

NOTE

See WP 0029, 0030, and 0031 for valuable information regarding applicable cable and connectors. The callout numbers are considered applicable to the appropriate illustration number in each legend given.

F-10 (Distribution Center Input Connector, M60, 60-Amp (J1))

Component Legend for Figure F-10

1. MS90564-3C COVER, ELECTRICAL CONNECTOR
2. MS90558C32405P CONNECTOR, ELECTRICAL RECEPTACLE
3. GASKET
4. M39029/48-318 CONTACT, ELECTRICAL PIN (G1, G2)
5. MS3348-6-8L REDUCER, CONTACT PIN (G1, G2)
6. M5086/2-8-9 WIRE, ELECTRICAL (G1, G2)
7. M5086/2-4-9 WIRE, ELECTRICAL (A, N)
8. M39029/48-320 CONTACT, ELECTRICAL PIN (A)
9. M39029/48-321 CONTACT, ELECTRICAL PIN (N)

- a. Cut and remove 3' of wire insulation as indicated. (WP 0029)
- b. Crimp electrical contact pins to wires for positions as noted in Table 11 below:

Table 11. Distribution Center Input Connector, M60, 60-Amp (J1)

POSITION	FIGURE ITEM NO.	WIRE SIZE	WIRE LENGTH
A	6 and 7	4	14 (355.6 MM)
N	6 and 8	4	14 (355.6 MM) G1
	4, 5, 1 and 9	8	14 (355.6 MM) G2
	4, 5, and 9	8	14 (355.6 MM)

- c. Electrical connector (Figure F-10, Item 2) is furnished with the following:
 - Cover (Item 1)
 - Gasket (Item 3)
 - Electrical contact pins (Items 4, 7, and 8)
- d. Assemble connector so keys/keyways and pins align as indicated.

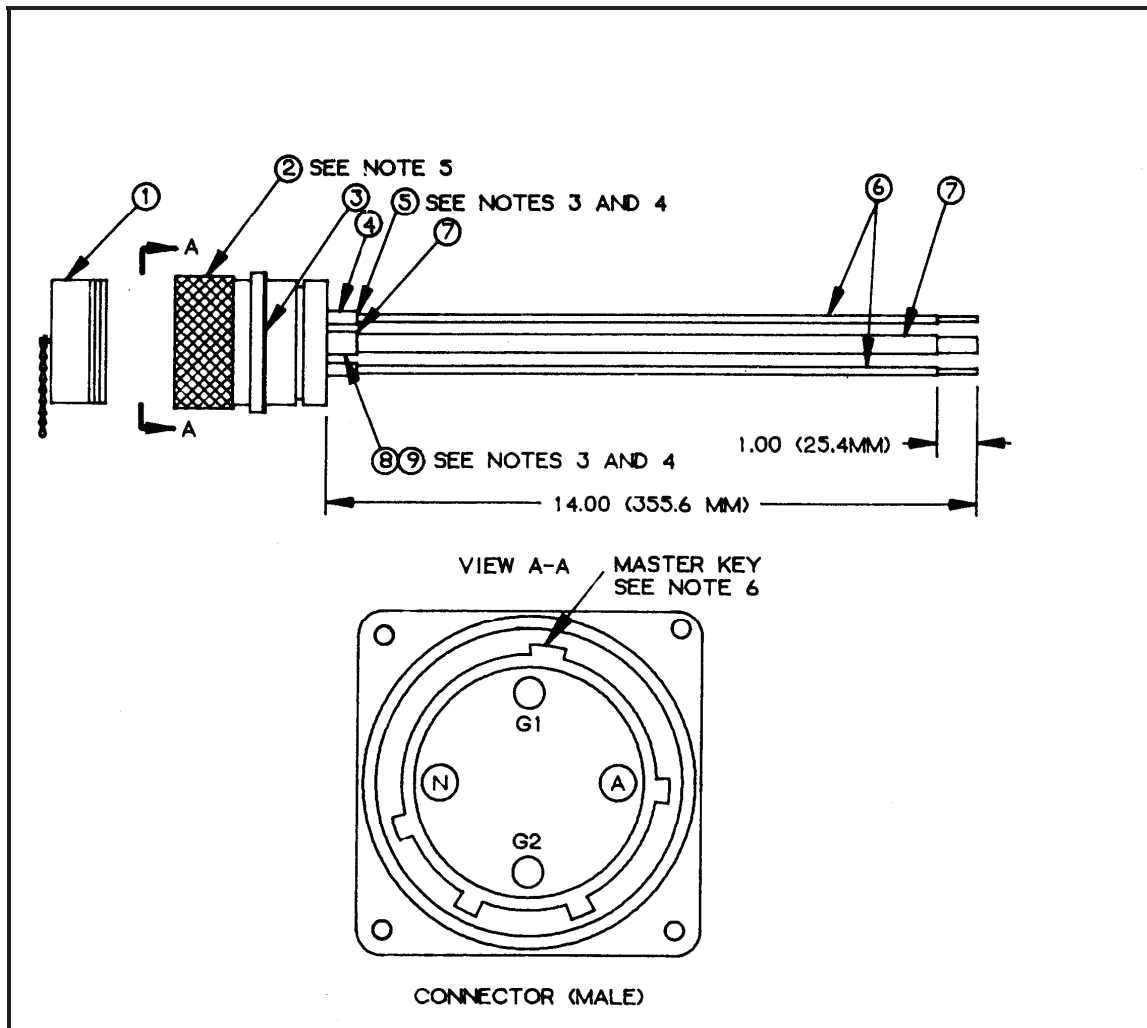

Figure F-10. Distribution Center Input Connector, M60, 60-Amp (J1)

NOTE

See WP 0029, 0030, and 0031 for valuable information regarding applicable cable and connectors. The callout numbers are considered applicable to the appropriate illustration number in each legend given.

F-11 (Distribution Center Output Connector Assembly, M60, 60-Amp (J2))

Component Legend for Figure F-11

1. MS90563-3C COVER, ELECTRICAL CONNECTOR
2. MS90555C32405S CONNECTOR, ELECTRICAL RECEPTACLE
3. GASKET
4. MS3348-6-8L REDUCER, ELECTRICAL SOCKET (G1, G2)
5. M39029/49-329 CONTACT, ELECTRICAL SOCKET (G1, G2)
6. M5086/2-4-9 WIRE, ELECTRICAL (G1, G2)
7. M5086/2-8-9 WIRE, ELECTRICAL (A, N)
8. M39029/49-331 CONTACT, ELECTRICAL SOCKET (A,N)

- a. Cut and remove 3' of wire insulation as indicated. (WP 0029)
- b. Crimp electrical contact pins to wires for positions as noted in Table 12 below:

Table 12. Output Connector Assembly, M60, 60-amp (J2).

POSITION	FIGURE ITEM NO.	WIRE SIZE	WIRE LENGTH
A	6 and 7	4	14 (355.6 MM)
N	6 and 8	4	14 (355.6 MM) G1
	4, 5, 1 and 9	8	14 (355.6 MM) G2
	4, 5, and 9	8	14 (355.6 MM)

c. Electrical connector (Figure F-11, Item 2) is furnished with the following:

- Cover (Item 1)
- Gasket (Item 3)
- Electrical contact pins (Items 5 and 8)

d. Assemble connector so keys/keyways and sockets align as indicated.

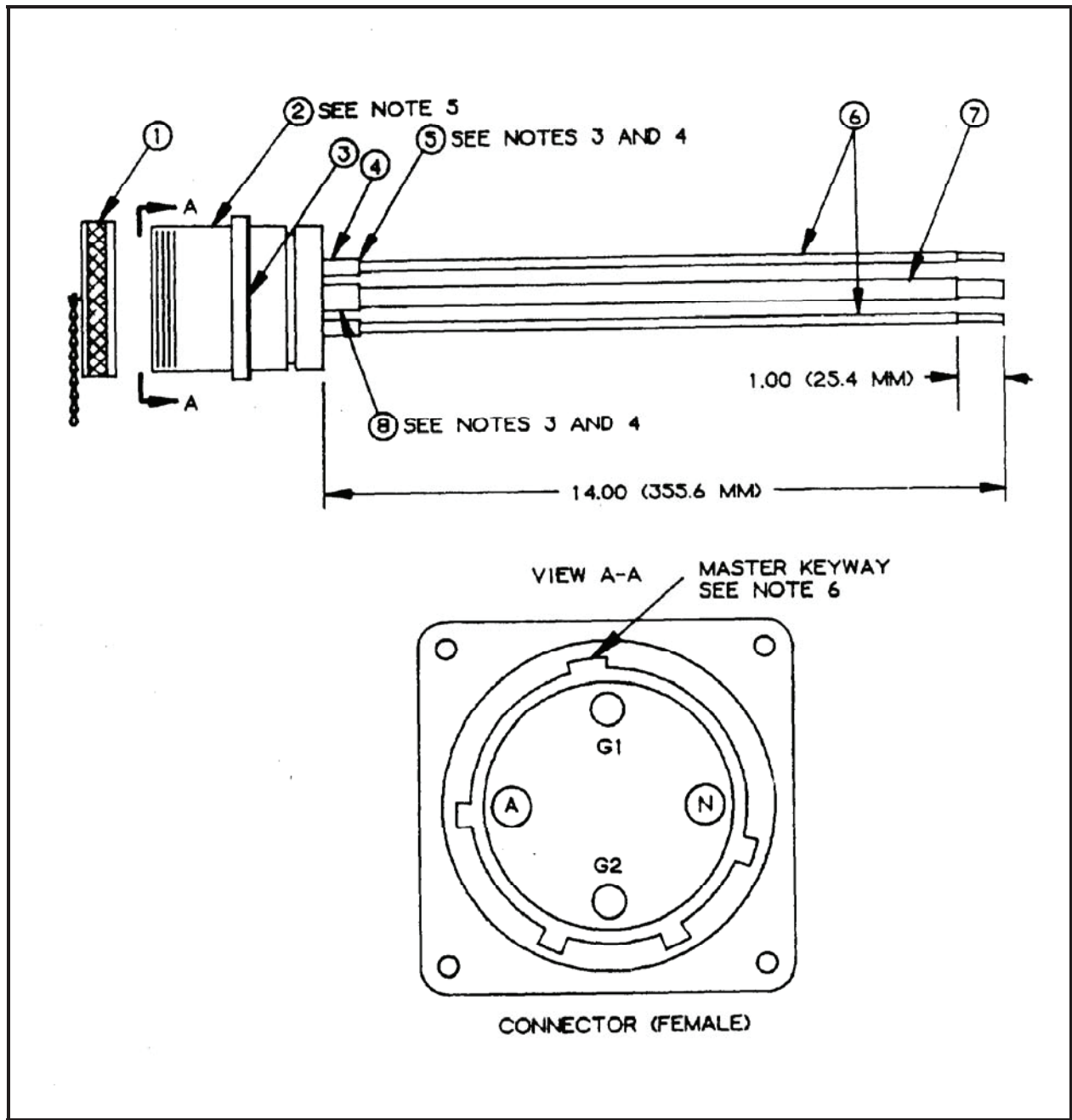

Figure F-11. Output Connector Assembly, M60, 60-Amp.

NOTE

See WP 0029, 0030, and 0031 for valuable information regarding applicable cable and connectors. The callout numbers are considered applicable to the appropriate illustration number in each legend given.

**F-12 (Distribution Center Output Connectors, M40, 20-Amp (J3 thru J14)
(Distribution Center Output Connector, M60, 20-Amp (J3 thru J8))**

Component Legend for Figure F-12

1. MS25043-16D COVER, ELECTRICAL CONNECTOR
2. MS3402D16-10S CONNECTOR, ELECTRICAL RECEPTACLE
3. GASKET
4. M5086/2-12-9 WIRE, ELECTRICAL (A, B, C)
5. M39029/30-219 SOCKET, ELECTRICAL CONTACT (A, B, C)

- a. Cut and remove 1/2' of wire insulation as indicated.
- b. Crimp electrical contact pins to wires for positions as noted in Table 13 below:

Table 13. Distribution Center Output Connector Assemblies, 20-Amp.

POSITION	FIGURE ITEM NO.	WIRE SIZE	WIRE LENGTH
A	4 and 5	12	11 (279.4 MM)
B	4 and 5	12	13 (330.2 MM)
C	4 and 5	12	11 (279.4 MM)

c. Electrical connector (Figure F-12, Item 2) is furnished with the following:

- Cover (Item 1)
- Gasket (Item 3)
- Electrical contact sockets (Items 5)

d. Assemble connector so keys/keyways and pins align as indicated.

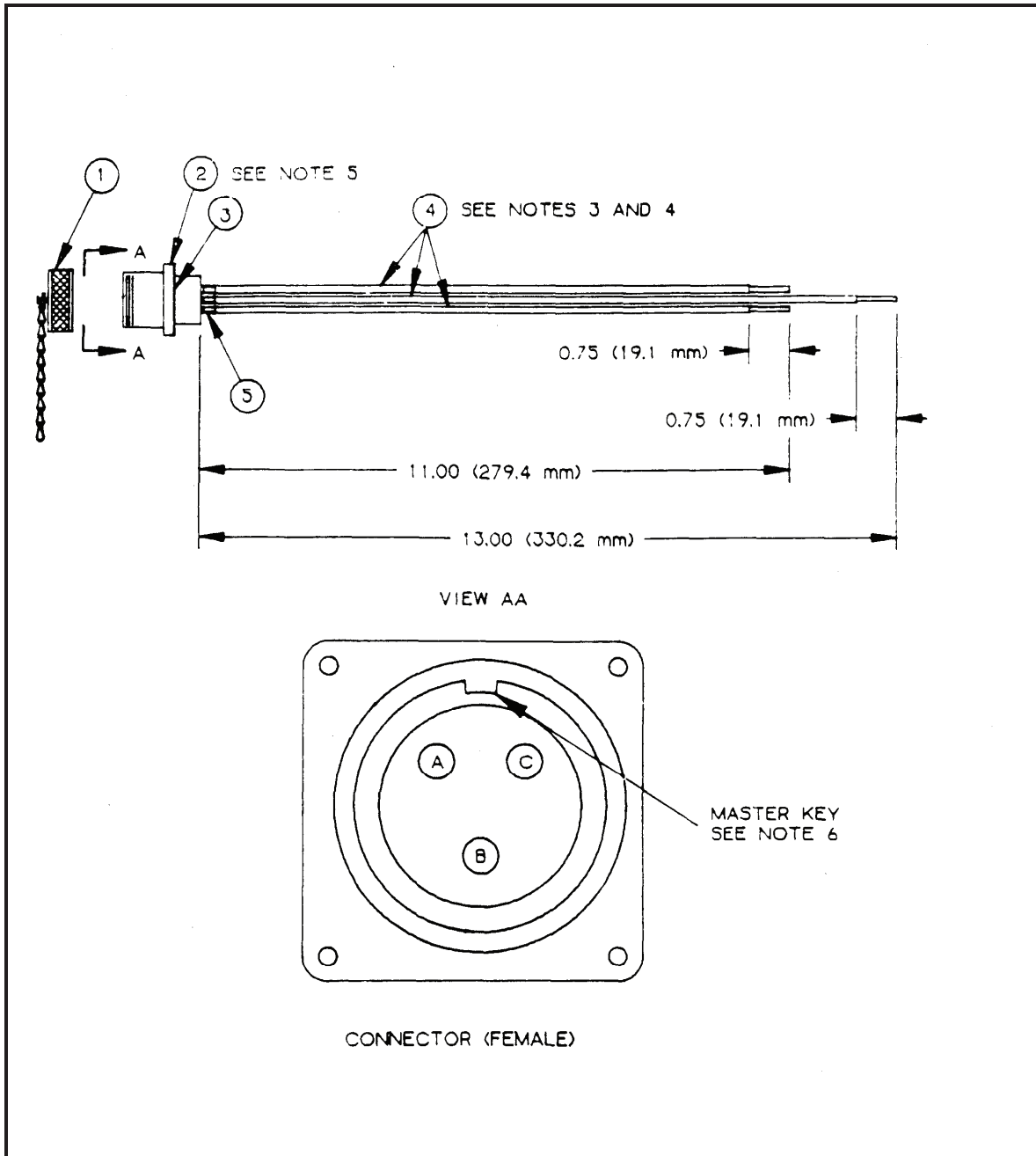

Figure F-12. Distribution Center Output Connector Assemblies, 20-Amp.

NOTE

See WP 0029, 0030, and 0031 for valuable information regarding applicable cable and connectors. The callout numbers are considered applicable to the appropriate illustration number in each legend given.

**F-13 (Feeder Center Output Connector, M200, 60-Amp (J6)
(Feeder Center Output Connector, M100, 60-Amp (J8))**

Component Legend for Figure F-13

1. MS25043-16D COVER, ELECTRICAL CONNECTOR
2. MS3402D16-10S CONNECTOR, ELECTRICAL RECEPTACLE
3. GASKET
4. M5086/2-19 WIRE, ELECTRICAL (A, B, C)
5. M39029/30-219 SOCKET, ELECTRICAL CONTACT (A, B, C)

- a. Cut and remove 3' of wire insulation as indicated. (WP 0029)
- b. Crimp electrical contact to wires for positions as noted in Table 14 below:

Table 14. Feeder Center Output Connector Assemblies, 60-Amp.

POSITION	FIGURE ITEM NO.	WIRE SIZE	WIRE LENGTH
A	4 and 5	12	14 (355.6 MM)
B	4 and 5	12	14 (335.6 MM)
C	4 and 5	12	14 (355.6 MM)

- c. Electrical connector (Figure F-13, Item 2) is furnished with the following:

- Cover (Item 1)
- Gasket (Item 3)
- Electrical contact sockets (Items 5)

- d. Assemble connector so keys/keyways and sockets align as indicated.

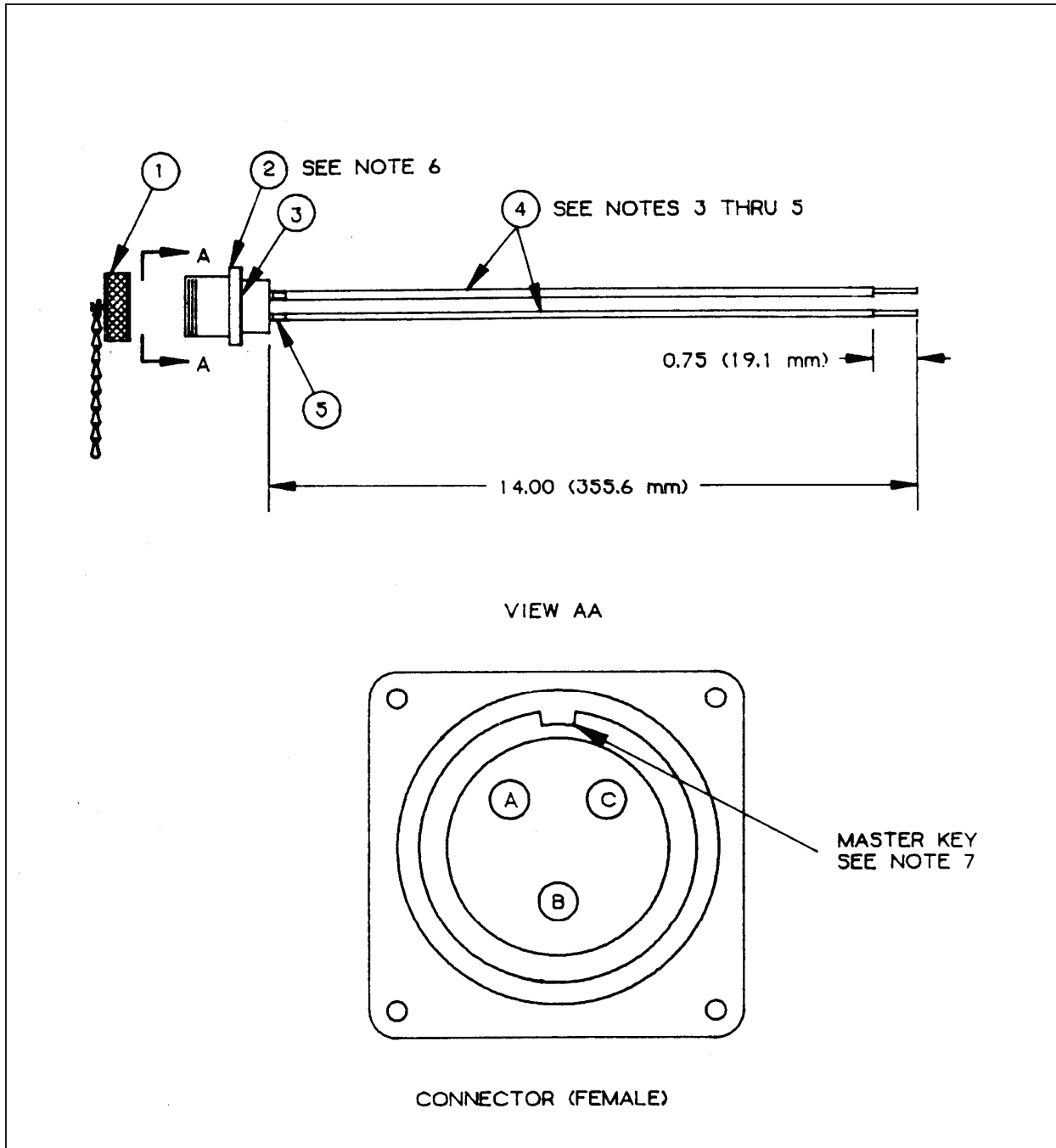

Figure F-13. Feeder Center Output Connector Assemblies, 60-Amp.

NOTE

See WP 0029, 0030, and 0031 for valuable information regarding applicable cable and connectors. The callout numbers are considered applicable to the appropriate illustration number in each legend given.

F-14 (Distribution Center Output Connector, M100, 20-amp (J7))

Component Legend for Figure F-14

1. MS25043-16D COVER, ELECTRICAL CONNECTOR
2. MS3402D16-10S CONNECTOR, ELECTRICAL RECEPTACLE
3. GASKET
4. M5086/2-19 WIRE, ELECTRICAL (A, B, C)
5. M39029/30-219 SOCKET, ELECTRICAL CONTACT (A, B, C)

- a. Cut and remove ½' of wire insulation as indicated. (WP 0029)
- b. Crimp electrical contact to wires for positions as noted in Table 15 below:

Table 15. Distribution Center Output Connector, M100, 20-amp (J7)

POSITION	FIGURE ITEM NO.	WIRE SIZE	WIRE LENGTH
A	4 and 5	12	28 (711.2 MM)
B	4 and 5	12	28 (711.2 MM)
C	4 and 5	12	28 (711.2 MM)

- c. Electrical connector (Figure F-14, Item 2) is furnished with the following:

- Cover (Item 1)
- Gasket (Item 3)
- Electrical contact sockets (Items 5)

- d. Assemble connector so keys/keyways and sockets align as indicated.

- c. Verify electrical continuity for each "From-To" path with multi-meter.
- d. Crimp pins/sockets to cable wires.
- e. Assemble P1 connector so key/keyway and sockets align as indicated.
- f. Mark sleeves in accordance with MIL-M-60903 as follows:

- 97403-13226E7021
- 120/208 VAC
- 3 PHASE
- 200 AMP

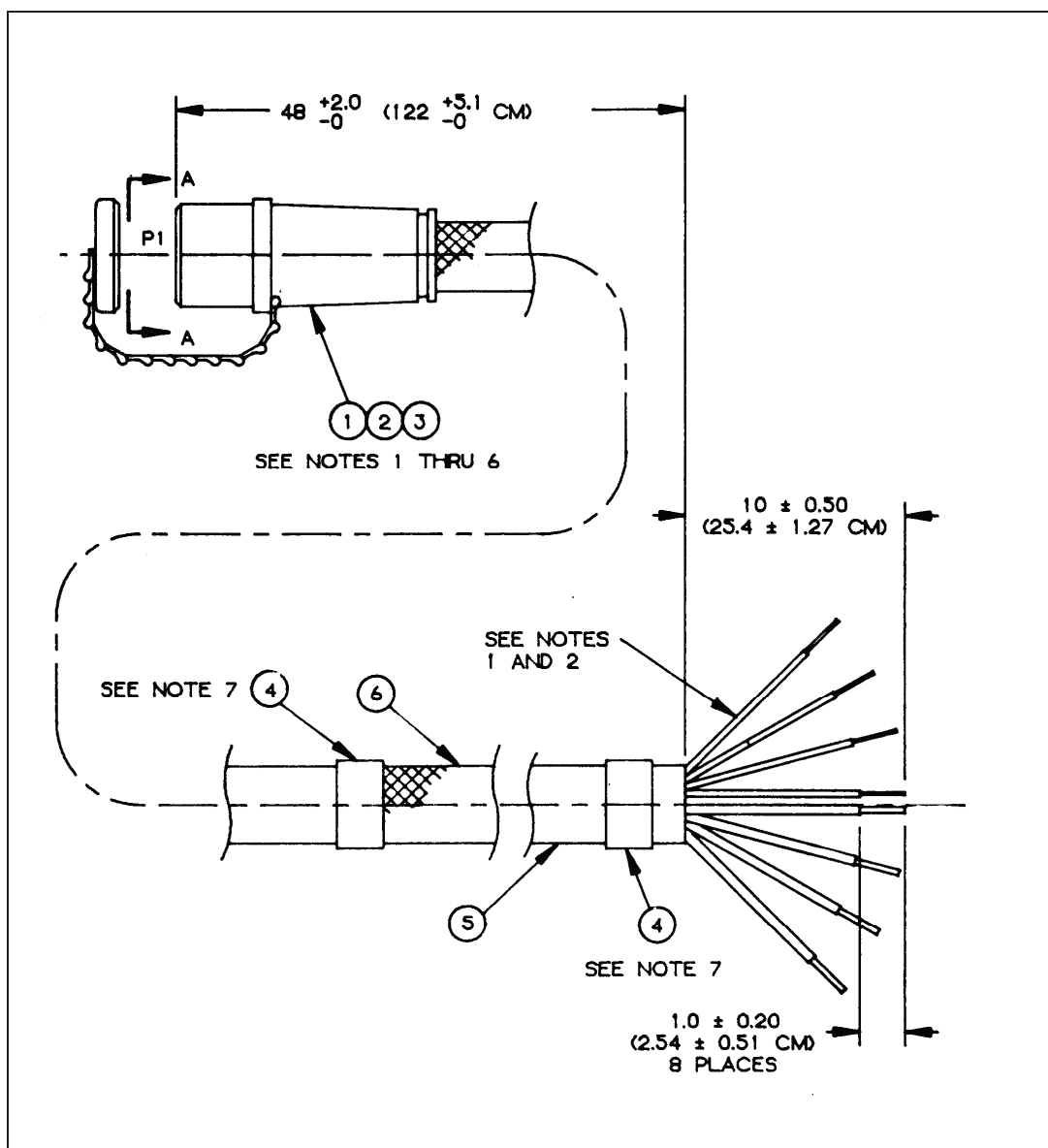

Figure F-15. Pigtail Cable, 200-Amp, (4-ft). (1 of 2)

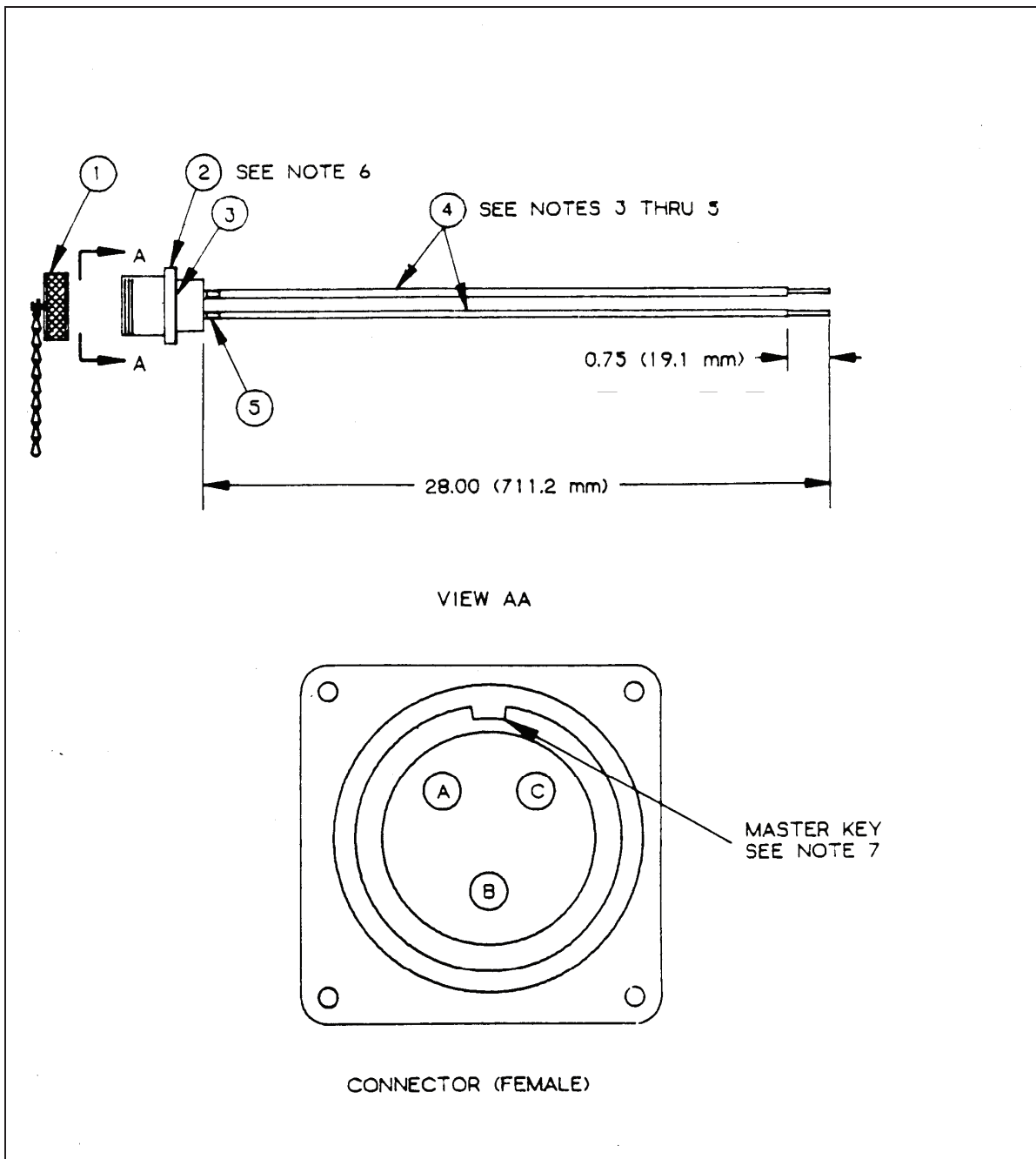

Figure F-14. Distribution Center Output Connector, M100, 20-amp (J7)

WARNING

High voltage is present in this system. DISE and PDISE support equipment using 120/208 VAC. Do not rely on the color of the wire insulation for phase color-coding. The insulation on the wires inside the cable jacket may vary, depending on the supplier. Wires will be marked with colored tape to designate the phases. Perform a continuity test to verify correct phase designation in accordance with the colored tape.

NOTE

See WP 0029, 0030, and 0031 for valuable information regarding applicable cable and connector information. The callout numbers are considered applicable to the appropriate illustration number in each legend given.

F-15 (Pigtail Cable, 200-Amp, (4-ft)

Component Legend for Figure F-15

1. MS90557C54213S CONNECTOR, ELECTRICAL SOCKET (P1)
2. M39029/49-335 CONTACT, ELECTRICAL SOCKET (P1-A, B, C, N)
3. M39029/49-332 CONTACT, ELECTRICAL SOCKET (P1-G1, G2, G3, G4)
4. M23053/5-114-4 SLEEVING, INSULATION, HEAT SHRINK
5. C0-04HDE (4/0000-4/4R) 2380 CABLE TAG, WARNING

- a. Cut and remove 4' in. of cable and 1' in. of wire insulation from cables as indicated. (WP 0029)
- b. Install P1 connector on proper cable end so colors and pins/sockets match as indicated in Table 16:

Table 16. Pigtail Cable, 200-Amp, (4-ft)

COLOR	FROM
BLACK	P1-A
RED	P1-B
BLUE	P1-C
WHITE	P1-N
GREEN (OR BARE)	P1-G1
GREEN (OR BARE)	P1-G2
GREEN (OR BARE)	P1-G3
GREEN (OR BARE)	P1-G4

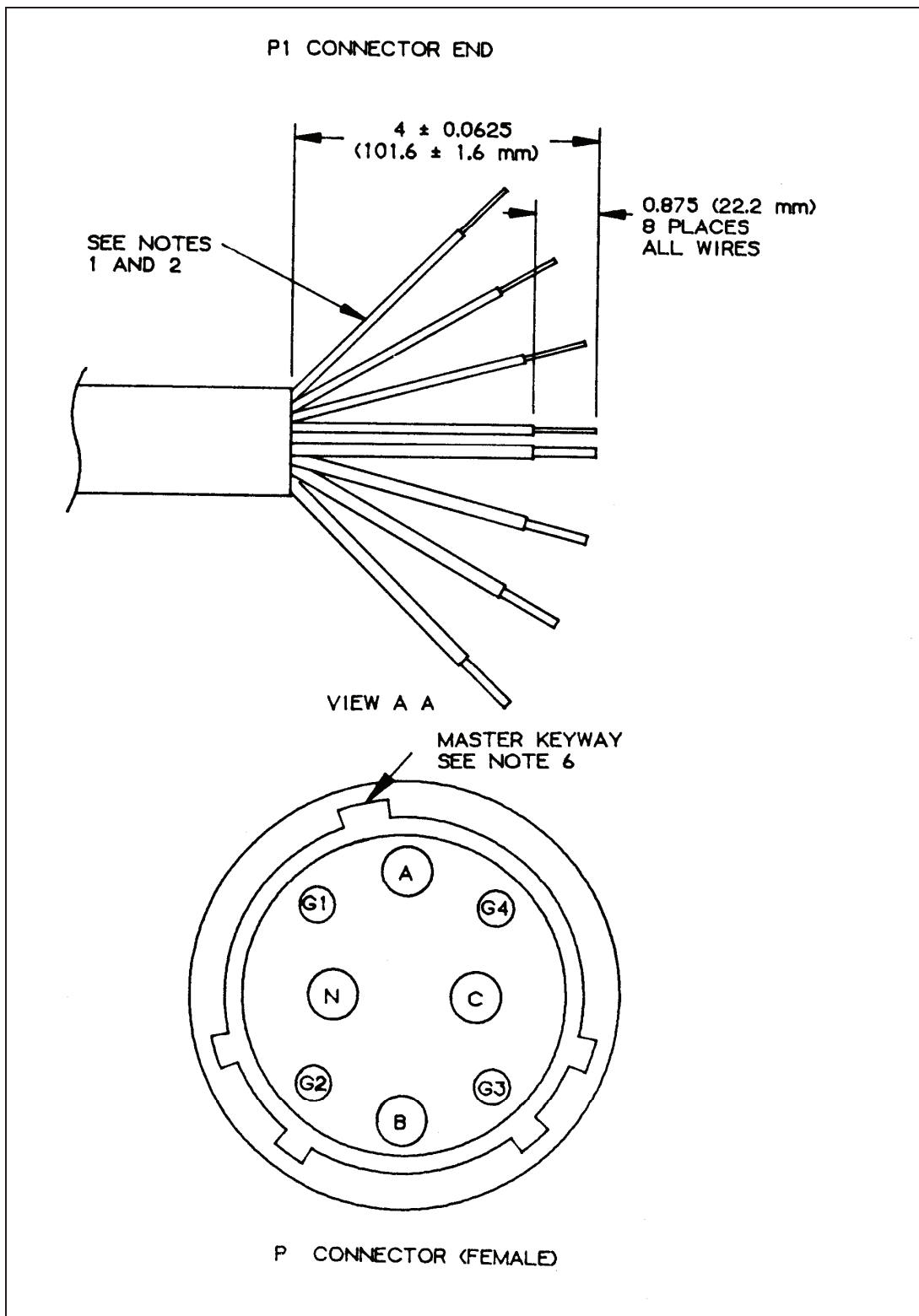

Figure F-15. Pigtail Cable, 200-Amp, (4-ft). (2 of 2)

WARNING

High voltage is present in this system. DISE and PDISE support equipment using 120/208 VAC. Do not rely on the color of the wire insulation for phase color-coding. The insulation on the wires inside the cable jacket may vary, depending on the supplier. Wires will be marked with colored tape to designate the phases. Perform a continuity test to verify correct phase designation in accordance with the colored tape.

NOTE

See WP 0029, 0030, and 0031 for valuable information regarding applicable cable and connector information. The callout numbers are considered applicable to the appropriate illustration number in each legend given.

F-16 (Pigtail Cable, 100-Amp, (4-ft))**Component Legend for Figure F-16**

1. MS90557C44413S CONNECTOR, ELECTRICAL RECEPTACLE (P1)
 2. MS3348-6-8L BUSHING, REDUCING (P1-G1, G2, G3, G4)
 3. M39029/49-330 CONTACT, ELECTRICAL SOCKET (P1-G1, G2, G3, G4)
 4. M39029/49-333 CONTACT, ELECTRICAL SOCKET (P1-A, B, C, N)
 5. M23053/5-113-4 SLEEVING, INSULATION, HEAT SHRINK
 6. CO-04HDF (4/1-4/8R) 1620 CABLE
 7. TAG, WARNING
- a. Cut and remove 3 ½ in. of cable and 1' in. of wire insulation from cables as indicated. (WP 0029)
 - b. Install P1 connector on proper cable end so colors and sockets match as indicated in Table 17:

Table 17. Pigtail Cable, 100-Amp, (4-ft).

COLOR	FROM
BLACK	P1-A
RED	P1-B
BLUE	P1-C
WHITE	P1-N
GREEN (OR BARE)	P1-G1
GREEN (OR BARE)	P1-G2
GREEN (OR BARE)	P1-G3
GREEN (OR BARE)	P1-G4

- d. Verify electrical continuity for each "From-To" path with multi-meter.
- e. Crimp pins/sockets to cable wires.
- f. Assemble P1 connector so key/keyway and sockets align as indicated.
- g. Mark sleeves in accordance with MIL-M-60903 as follows:

- 97403-13226E7020
- 120/208 VAC
- 3 PHASE
- 100 AMP

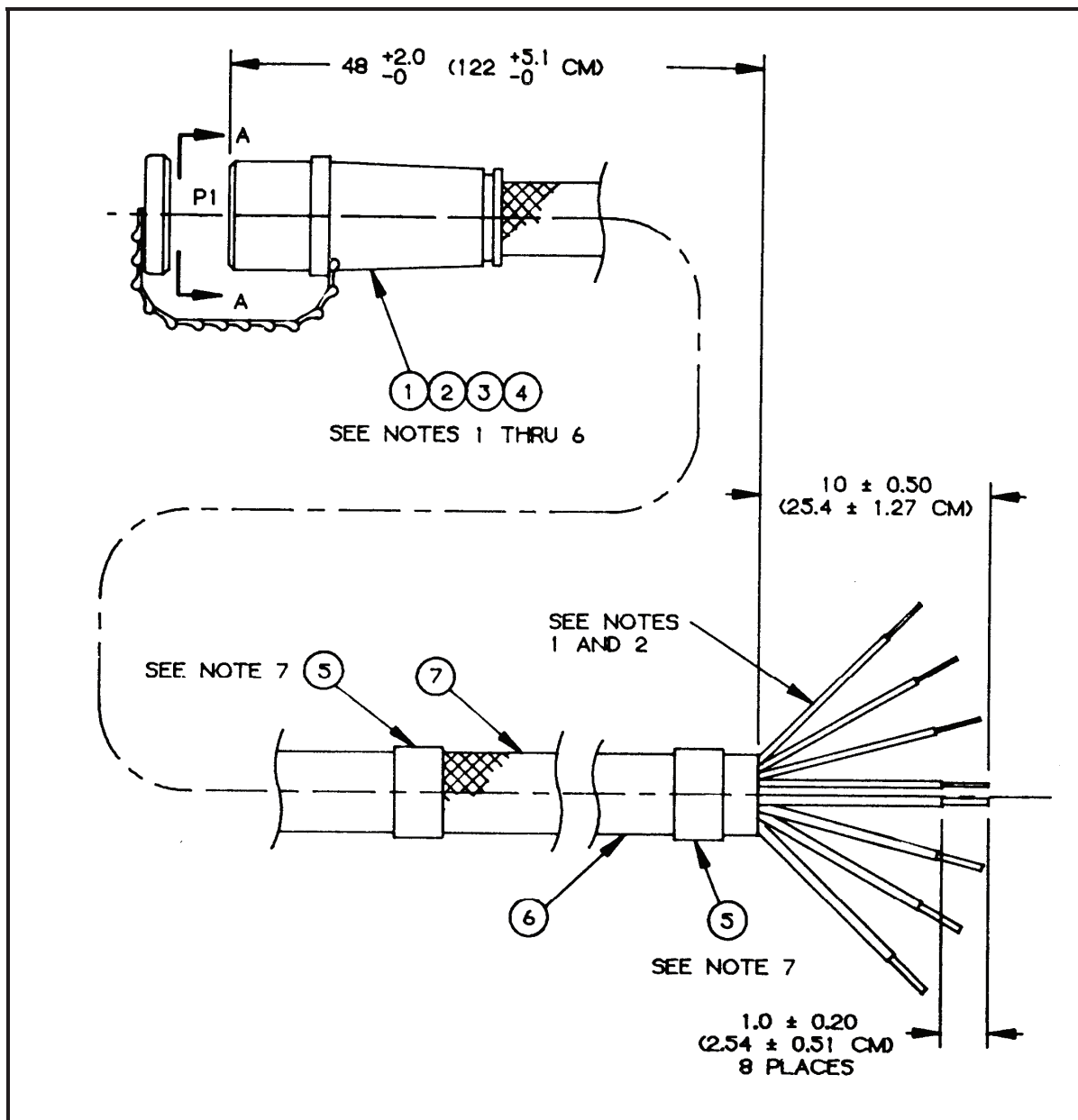

Figure F-16. Pigtail Cable, 100-Amp, (4-ft). (1 of 2)

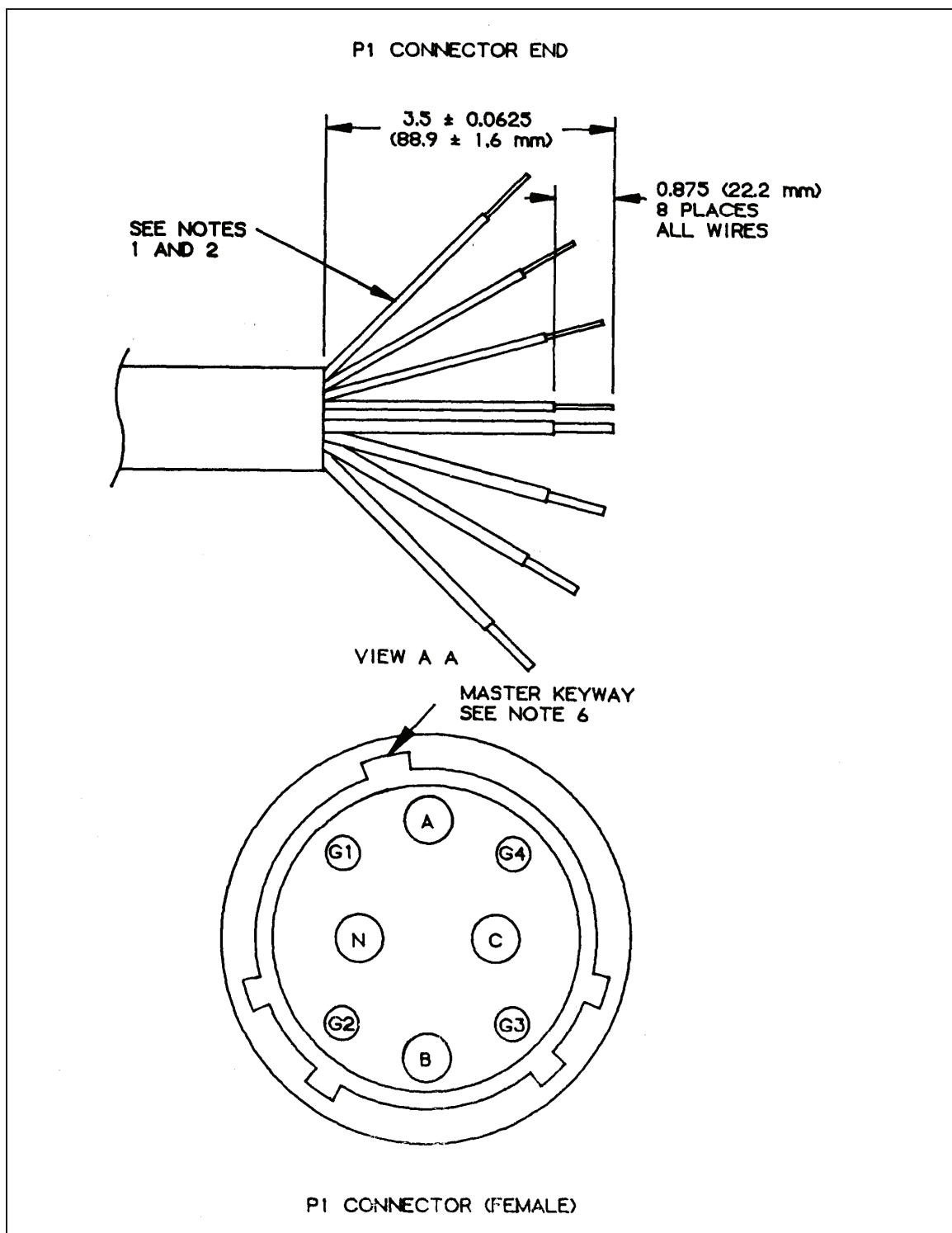

Figure F-16. Pigtail Cable, 100-Amp, (4-ft). (2 of 2)

WARNING

High voltage is present in this system. DISE and PDISE support equipment using 120/208 VAC. Do not rely on the color of the wire insulation for phase color-coding. The insulation on the wires inside the cable jacket may vary, depending on the supplier. Wires will be marked with colored tape to designate the phases. Perform a continuity test to verify correct phase designation in accordance with the colored tape.

NOTE

See WP 0029, 0030, and 0031 for valuable information regarding applicable cable and connector information. The callout numbers are considered applicable to the appropriate illustration number in each legend given.

F-17 (Pigtail Cable, 40/60-Amp, (4-ft)

Component Legend for Figure F-17

1. MS90557C32413S CONNECTOR, E1 ELECTRICAL RECEPTACLE (P1)
2. M39029/39-331 CONTACT, ELECTRICAL SOCKET (P1-A, B, C, N)
3. M39029/39-329 CONTACT, ELECTRICAL SOCKET (P1-G)
4. M23053/5-112-4 SLEEVING, INSULATION, HEAT SHRINK
5. CO-04HDF (4/4-4/1A) CABLE
6. TAG, WARNING

- a. Cut and remove 4' in. of cable 1' in. of wire insulation from cables as indicated. (WP 0029)
- b. Install P1 connector on proper cable end so colors and sockets match as indicated in Table 18:

Table 18. Pigtail Cable, 40/60-Amp, (4-ft)

COLOR	FROM
BLACK	P1-A
RED	P1-B
BLUE	P1-C
WHITE	P1-N
GREEN (OR BARE)	P1-G
GREEN (OR BARE)	
GREEN (OR BARE)	
GREEN (OR BARE)	

- d. Verify electrical continuity for each "From-To" path with multi-meter.
- e. Crimp pins/sockets to cable wires.
- f. Assemble P1 connector so key/keyway and sockets align as indicated.
- g. Mark sleeves in accordance with MIL-M-60903 as follows:

- 97403-13226E7019
- 120/208 VAC
- 3 PHASE
- 40/60 AMP

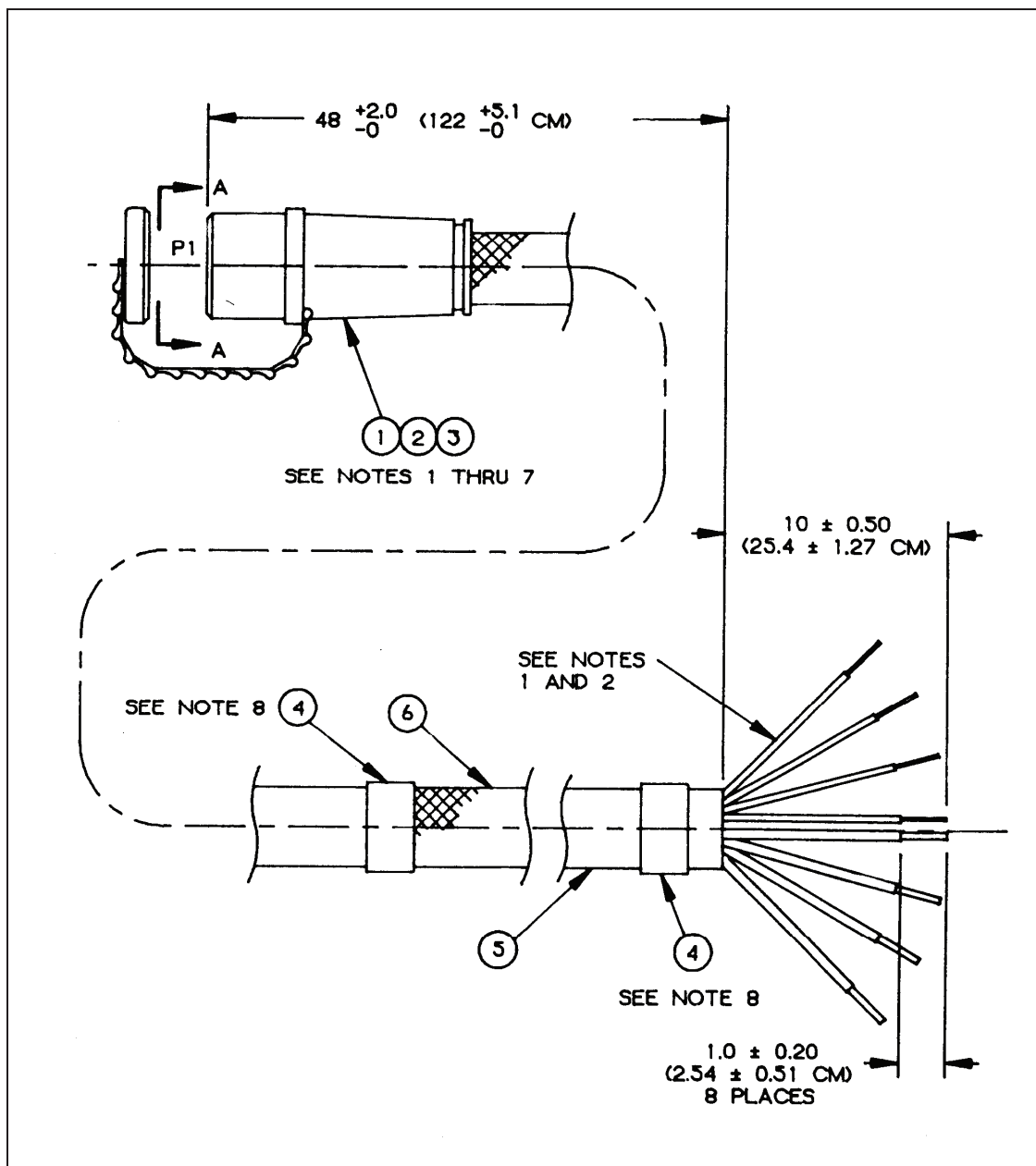

Figure F-17. Pigtail Cable, 40/60-Amp, (4-ft). (1 of 2)

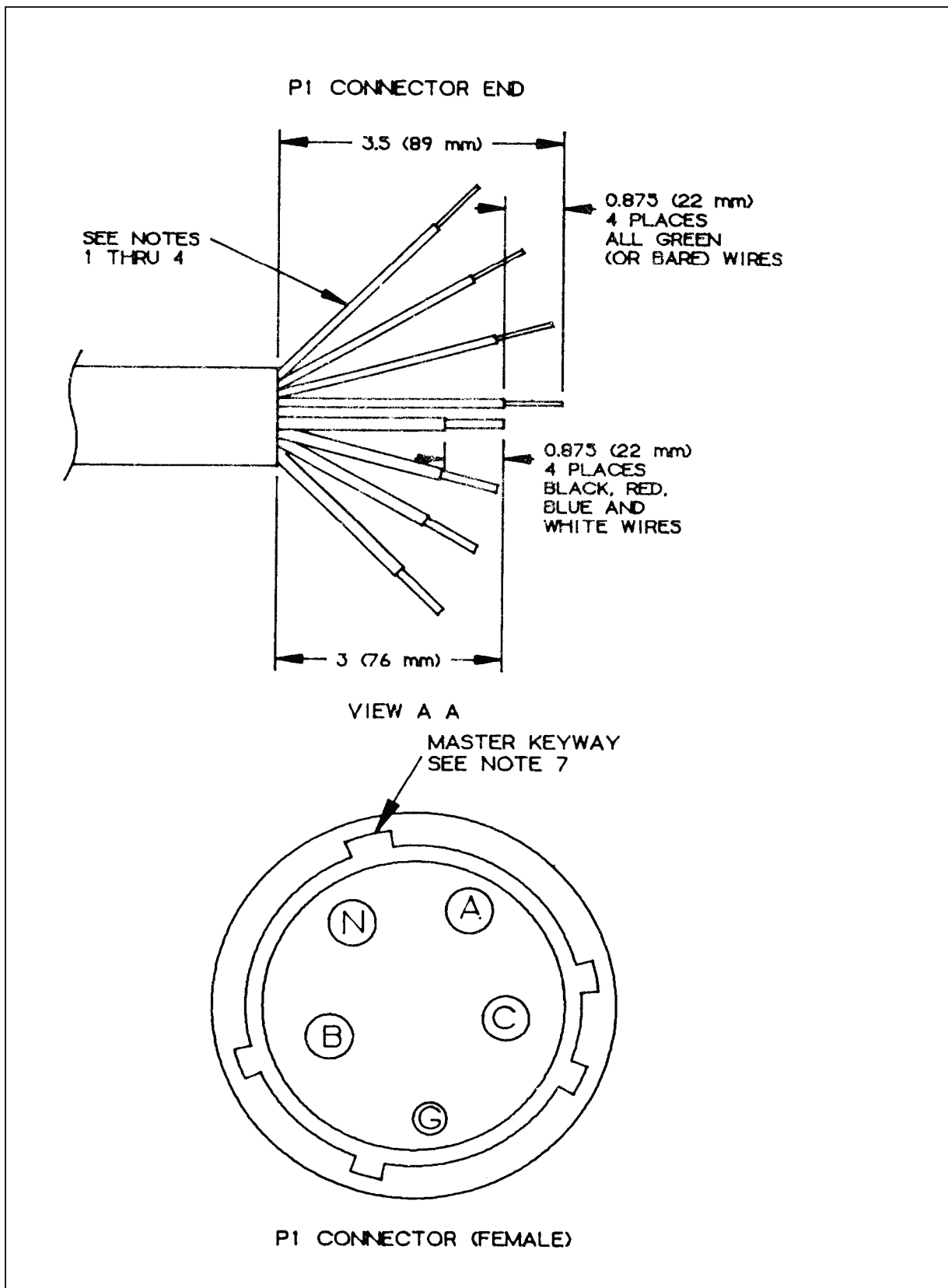

Figure F-17. Pigtail Cable, 40/60-Amp, (4-ft). (2 of 2)

WARNING

High voltage is present in this system. DISE and PDISE support equipment using 120/208 VAC. Do not rely on the color of the wire insulation for phase color-coding. The insulation on the wires inside the cable jacket may vary, depending on the supplier. Wires will be marked with colored tape to designate the phases. Perform a continuity test to verify correct phase designation in accordance with the colored tape.

NOTE

See WP 0029, 0030, and 0031 for valuable information regarding applicable cable and connector information. The callout numbers are considered applicable to the appropriate illustration number in each legend given.

F-18 (Pigtail Cable, 60-Amp, (4-ft)

Component Legend for Figure F-18

1. MS3102R16-10S CONNECTOR, ELECTRICAL RECEPTACLE (P1)
 2. M90929/49-331 CONTACT, ELECTRICAL SOCKET (P1-A, N)
 3. MS3348-6-8L BUSHING REDUCING # 6 AWG (P1-G)
 4. M39029/38-329 CONTACT, ELECTRICAL SOCKET (P1-G)
 5. M2305315-112-4 SLEEVING, INSULATION, HEAT SHRINK
 6. C0-02HDF (2/4-2/8R) 1290 CABLE
 7. TAG, WARNING
- a. Cut and remove 3-in of cable and 7/8 in. of wire insulation from cables as indicated. (WP 0029)
 - b. Install P1 connector on proper cable end so colors and socket match as indicated in Table 19:

Table 19. Pigtail Cable, 60-Amp, (4-ft)

COLOR	FROM
BLACK	P1-A
WHITE	P1-N
GREEN (OR BARE)	P1-G1
GREEN (OR BARE)	P1-G2

- d. Verify electrical continuity for each "From-To" path with multi-meter.
- e. Crimp pins/sockets to cable wires.
- f. Assemble P1 connector so key/keyway and pins/socket align as indicated.
- g. Mark sleeves in accordance with MIL-M-60903 as follows:

- 97403-13226E7018
- 120/208 VAC
- SINGLE PHASE
- 60 AMP

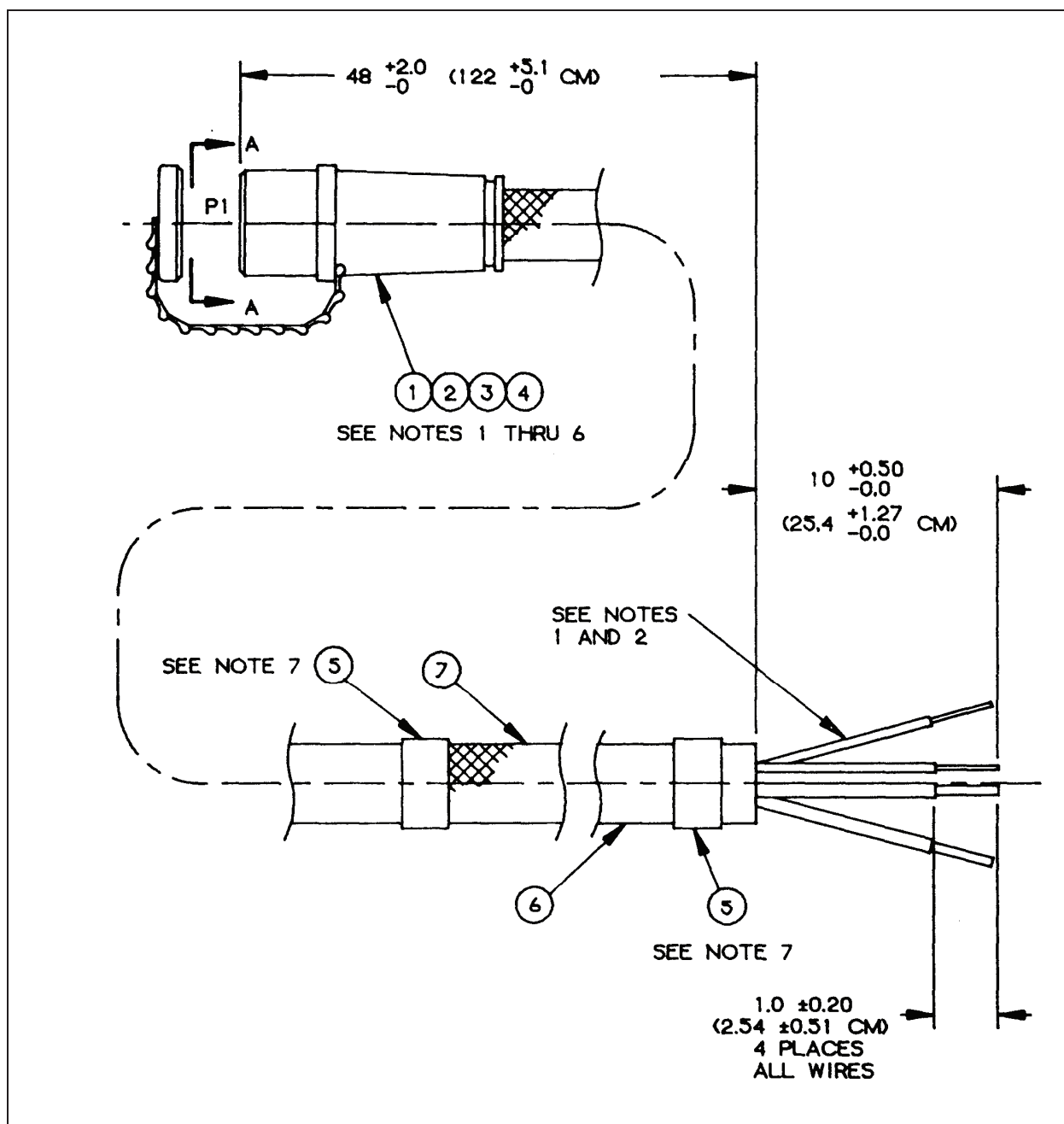

Figure F-18. Pigtail Cable, 60-Amp, (4-ft). (1 of 2)

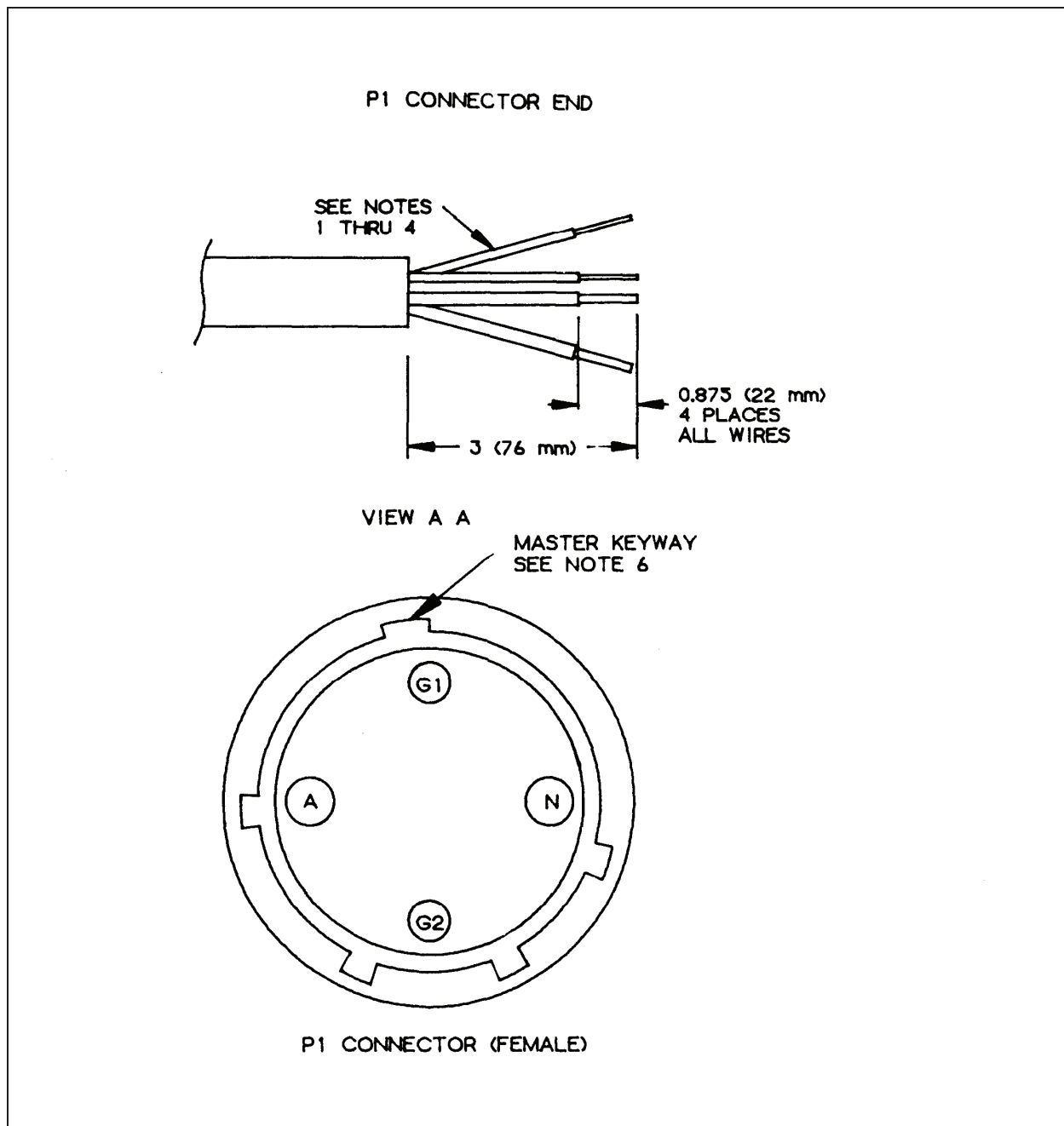

Figure F-18. Pigtail Cable, 60-Amp, (4-ft). (2 of 2)

WARNING

High voltage is present in this system. DISE and PDISE support equipment using 120/208 VAC. Do not rely on the color of the wire insulation for phase color-coding. The insulation on the wires inside the cable jacket may vary, depending on the supplier. Wires will be marked with colored tape to designate the phases. Perform a continuity test to verify correct phase designation in accordance with the colored tape.

NOTE

See WP 0029, 0030, and 0031 for valuable information regarding applicable cable and connector information. The callout numbers are considered applicable to the appropriate illustration number in each legend given.

F-19 (Service/Feeder Cable, 200-Amp, (25-ft)

Component Legend for Figure F-19

1. MS90556C52413P CONNECTOR, ELECTRICAL STRAIGHT PLUG (P1)
 2. M39029/48-327 CONTACT, ELECTRICAL PIN (P1-A, B, C)
 3. M39029/48-328 CONTACT, ELECTRICAL PIN (P1-N)
 4. M39029/48-322 CONTACT, ELECTRICAL PIN (P1-G1, G2, G3, G4)
 5. M23053/5-114-4 SLEEVING, INSULATION, HEAT SHRINK
 6. CO-04HDF (4/0000-4/4R) 2380 CABLE
 7. MS90557C52405S CONNECTOR, ELECTRICAL RECEPTACLE (P2)
 8. M39029/49-335 CONTACT, ELECTRICAL SOCKET (P2-A, B, C, N)
 9. M39029/49-332 CONTACT, ELECTRICAL SOCKET (P2-G1, G2, G3, G4)
 10. TAG, WARNING
- a. Cut and remove 4 1/6' of cable and 7/8' of wire insulation from cables as indicated. (WP 0029)
 - b. Install P1 and P2 connectors on proper cable ends so colors and sockets match as indicated in Table 20:

Table 20. Service/Feeder Cable, 200-Amp, (25-ft)

COLOR	FROM	TO
BLACK	P1-A	P2-A
RED	P1-B	P2-B
BLUE	P1-C	P2-C
WHITE	P1-N	P2-N
GREEN (OR BARE)	P1-G1	P2-G1
GREEN (OR BARE)	P1-G2	P2-G2
GREEN (OR BARE)	P1-G3	P2-G3
GREEN (OR BARE)	P1-G4	P2-G4

- d. Verify electrical continuity for each "From-To" path with multi-meter.
- e. Crimp pins/sockets to cable wires.
- f. Assemble P1 and P2 connectors so keys/keyways and sockets align as indicated.
- g. Mark sleeves in accordance with MIL-M-60903 as follows:

- 97403-13226E7025
- 120/208 VAC
- 3 PHASE
- 200 AMP

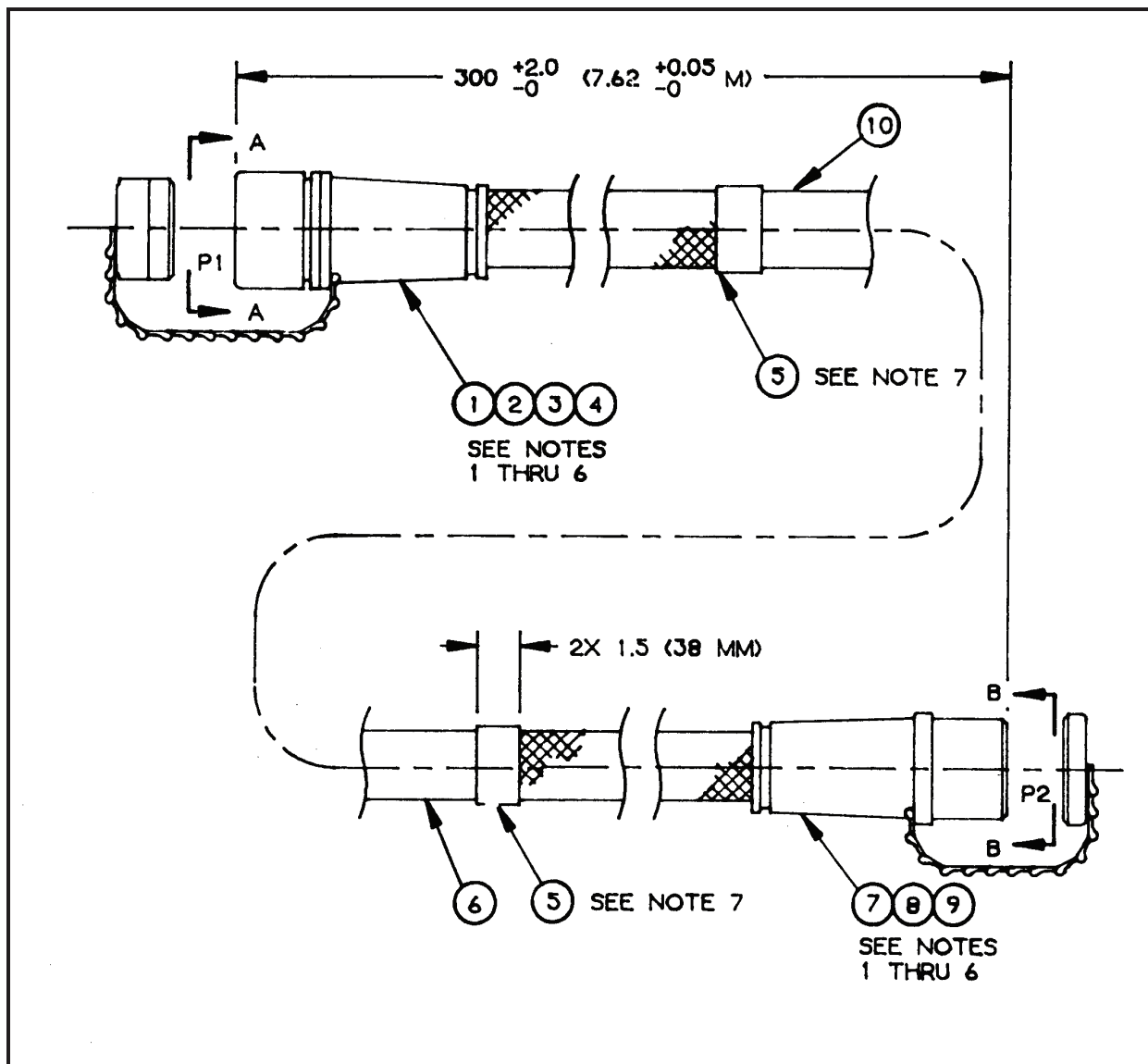

Figure 19. Service/Feeder Cable, 200-Amp, (25-ft). (1 of 2)

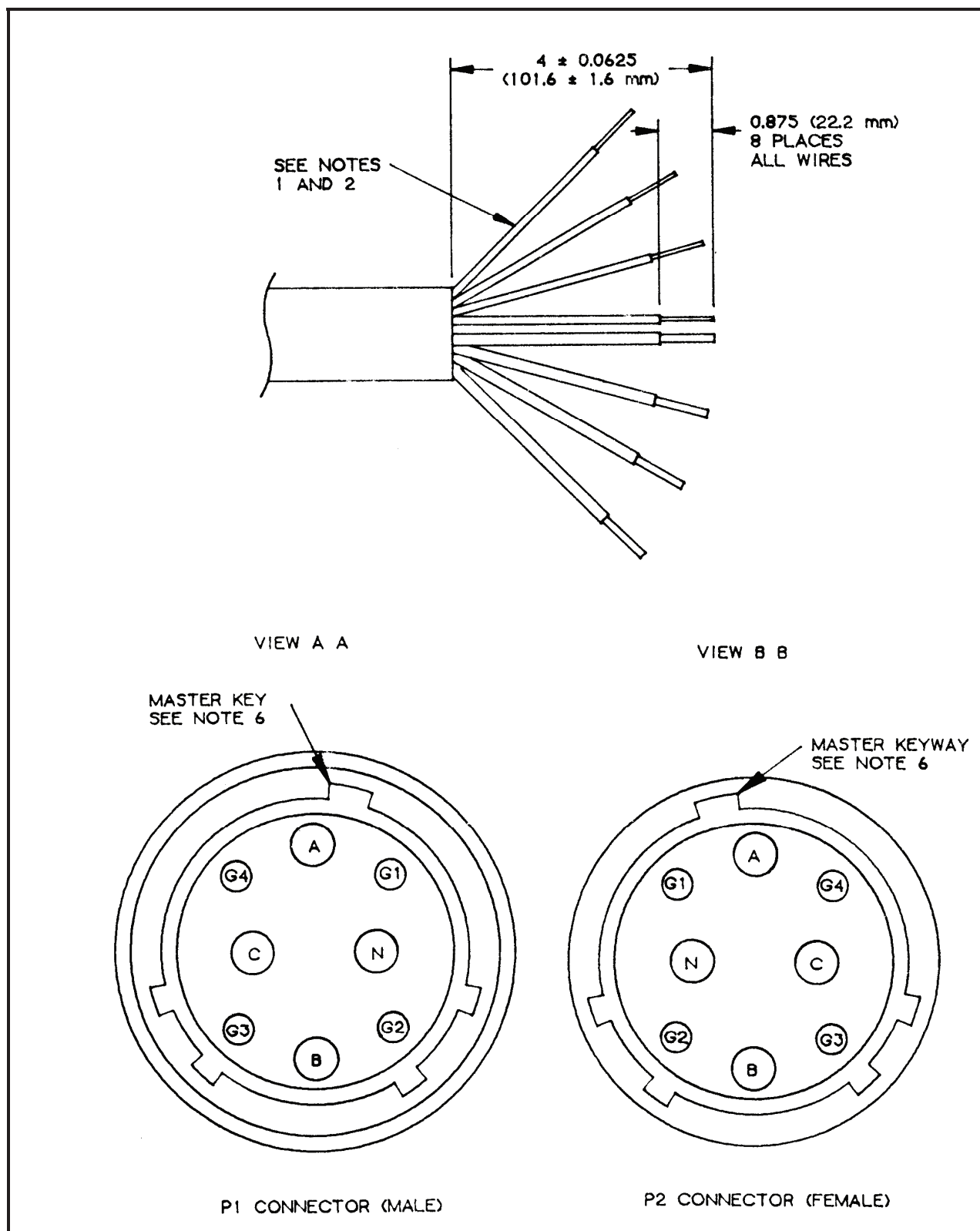

Figure F-19. Service/Feeder Cable, 200-Amp, (25-ft). (2 of 2)

WARNING

High voltage is present in this system. DISE and PDISE support equipment using 120/208 VAC. Do not rely on the color of the wire insulation for phase color-coding. The insulation on the wires inside the cable jacket may vary, depending on the supplier. Wires will be marked with colored tape to designate the phases. Perform a continuity test to verify correct phase designation in accordance with the colored tape.

NOTE

See WP 0029, 0030, and 0031 for valuable information regarding applicable cable and connector information. The callout numbers are considered applicable to the appropriate illustration number in each legend given.

F-20 (Service/Feeder Cable, 100-Amp, (50-ft)

Component Legend for Figure F-20

1. MS90556C44413P CONNECTOR, ELECTRICAL STRAIGHT PLUG (P1)
2. M39029/48-323 CONTACT, ELECTRICAL PIN (P1-A, B, C)
3. M39029/48-324 CONTACT, ELECTRICAL PIN (P1-N)
4. M39029/48-319 CONTACT, ELECTRICAL PIN (P1-G1, G2, G3, G4)
5. MS3348-6-8L REDUCER, ELECTRICAL CONTACT (P1 AND P2-G1, G2, G3, G4)
6. M23054/5-113-4 SLEEVING, INSULATION, HEAT SHRINK
7. CO-04HDF (4/1-4/8R) 1620 CABLE
8. MS90557C44413S CONNECTOR, ELECTRICAL RECEPTACLE (P2)
9. M39029/49-333 CONTACT, ELECTRICAL SOCKET (P2-A, B, C, M)
10. M39029/49-330 CONTACT; ELECTRICAL SOCKET (P2-G1, G2, G3, G4)
11. TAG, WARNING

- a. Cut and remove 3 1/2' of cable and 7/8' of wire insulation from cables as indicated. (WP 0029)
- b. Install P1 and P2 connectors on proper cable ends so colors and sockets match as indicated in Table 21:

Table 21. Service/Feeder Cable, 100-Amp, (50-ft)

COLOR	FROM	TO
BLACK	P1-A	P2-A
RED	P1-B	P2-B
BLUE	P1-C	P2-C
WHITE	P1-N	P2-N
GREEN (OR BARE)	P1-G1	P2-G1
GREEN (OR BARE)	P1-G2	P2-G2
GREEN (OR BARE)	P1-G3	P2-G3
GREEN (OR BARE)	P1-G4	P2-G4

- d. Verify electrical continuity for each "From-To" path with multi-meter.
- e. Crimp pins/sockets to cable wires.
- f. Assemble P1 and P2 connectors so keys/keyways and sockets align as indicated.

g. Mark sleeves in accordance with MIL-M-60903 as follows:

- 97403-13226E7024
- 120/208 VAC
- 3 PHASE
- 100 AMP

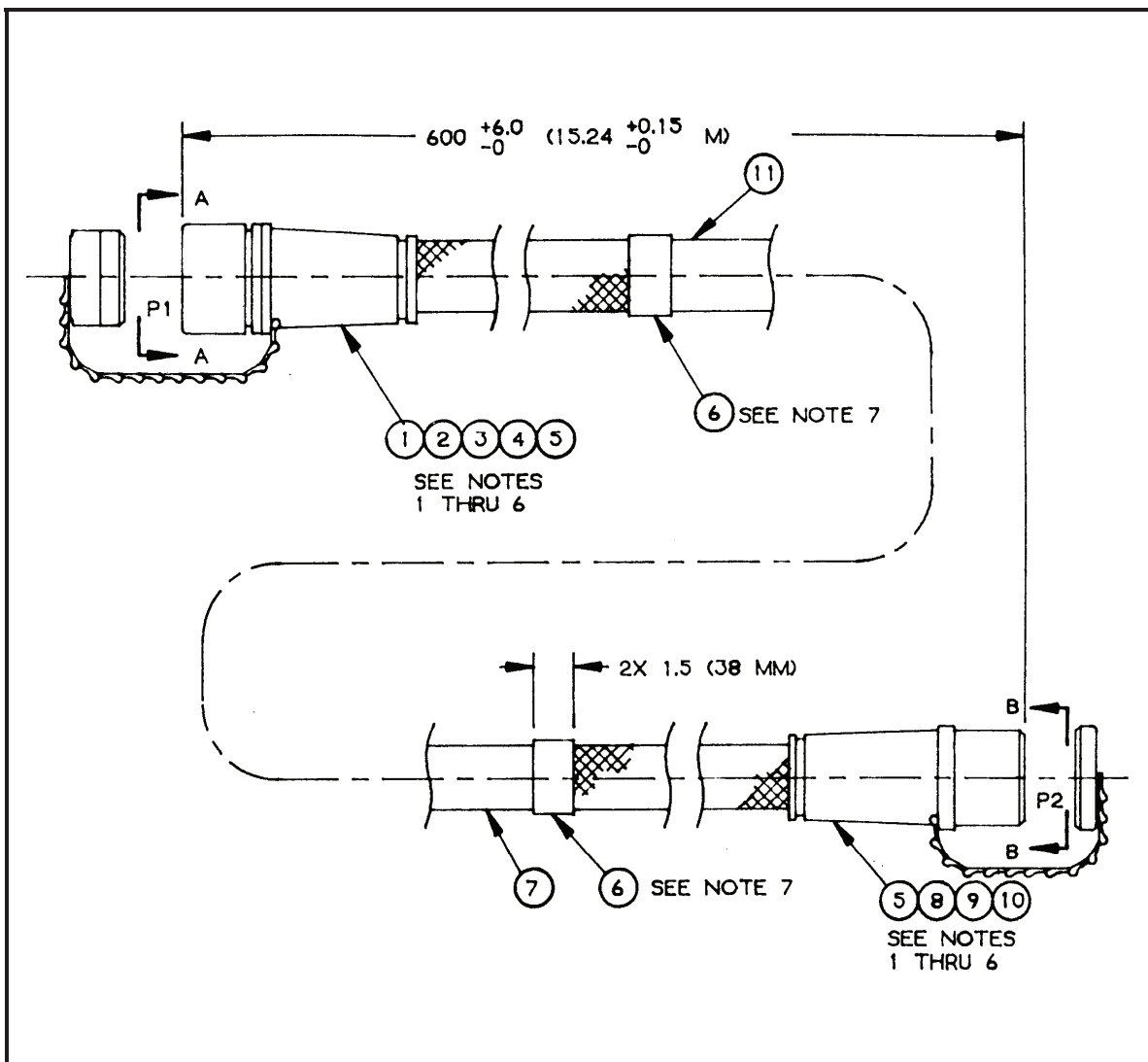

Figure F-20. Service/Feeder Cable, 100-Amp, (50-ft). (1 of 2)

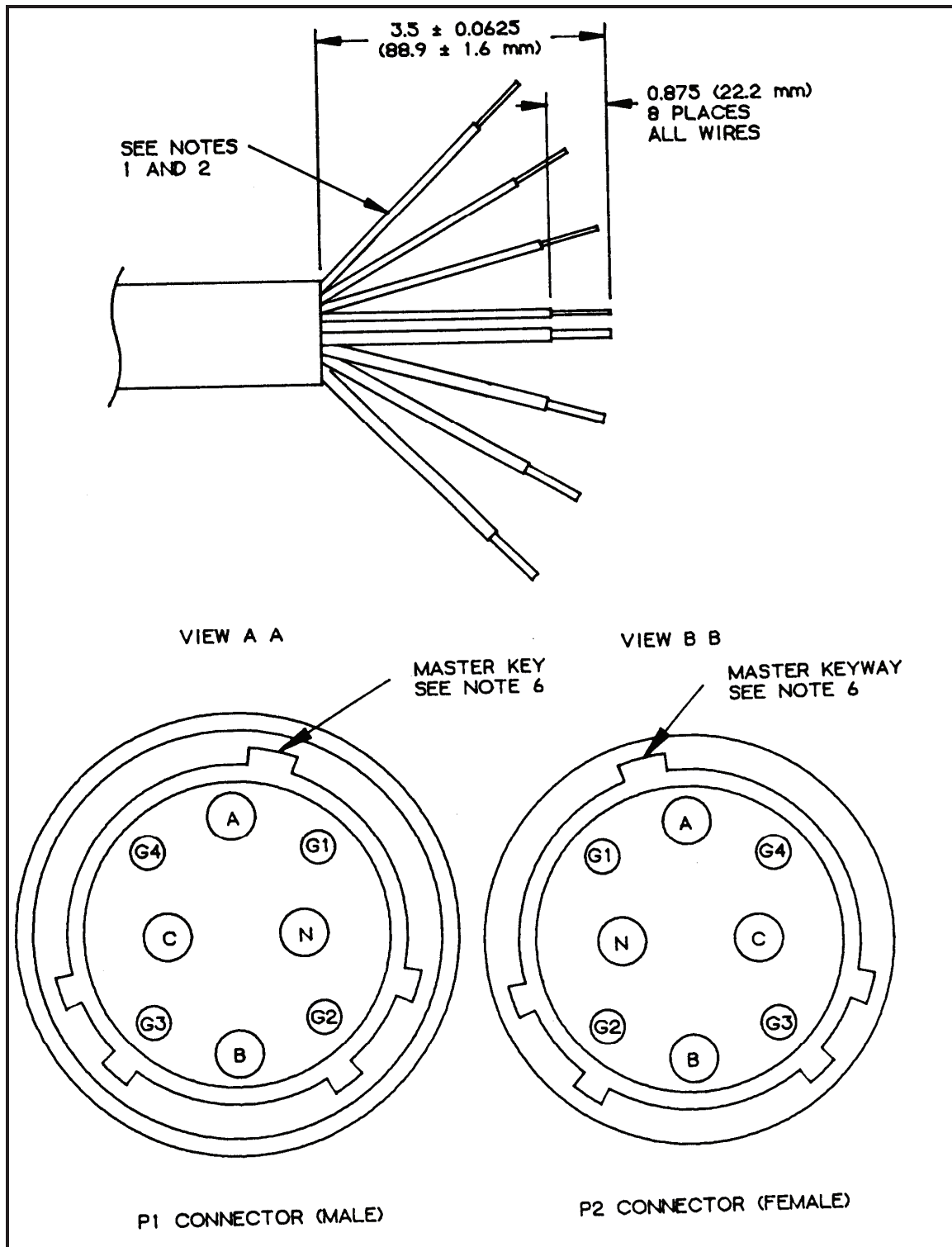

Figure F-20. Service/Feeder Cable, 100-Amp, (50-ft) (2 of 2)

WARNING

High voltage is present in this system. DISE and PDISE support equipment using 120/208 VAC. Do not rely on the color of the wire insulation for phase color-coding. The insulation on the wires inside the cable jacket may vary, depending on the supplier. Wires will be marked with colored tape to designate the phases. Perform a continuity test to verify correct phase designation in accordance with the colored tape.

NOTE

See WP 0029, 0030, and 0031 for valuable information regarding applicable cable and connector information. The callout numbers are considered applicable to the appropriate illustration number in each legend given.

F-21 (Service/Feeder Cable, 200-Amp, 40/60-Amp (25-ft))

Component Legend for Figure F-21

1. MS90556C32413P CONNECTOR, ELECTRICAL STRAIGHT PLUG (P1)
2. M39029/48-320 CONTACT, ELECTRICAL PIN (P1-A, B, C)
3. M39029/48-321 CONTACT, ELECTRICAL PIN (P1-N)
4. M39029/48-318 CONTACT, ELECTRICAL PIN (P1-G1)
5. MS3348-6-8L REDUCER, ELECTRICAL CONTACT (P1-G, P2-G)
6. M23053/5-112-4 SLEEVING, INSULATION, HEAT SHRINK
7. C0-04HDF (4/4-4/12R) 1290 CABLE
8. MS90557C32413S CONNECTOR, ELECTRICAL RECEPTACLE (P2)
9. M39029/49-331 CONTACT, ELECTRICAL SOCKET (P2-A, B, C, N)
10. M39029/49-329 CONTACT, ELECTRICAL SOCKET (P2-G)
11. TAG, WARNING

- a. Cut and remove 3 1/2' of cable and 1/2' of wire insulation from cables as indicated. (WP 0029)
- b. Install P1 and P2 connectors on proper cable ends so colors and sockets match as indicated in Table 22:

Table 22. Service/Feeder Cable, 200-Amp, 40/60-Amp (25-ft)

COLOR	FROM	TO
BLACK	P1-A	P2-A
RED	P1-B	P2-B
BLUE	P1-C	P2-C
WHITE	P1-N	P2-N
GREEN (OR BARE) GREEN (OR BARE) GREEN (OR BARE) GREEN (OR BARE)	P1-G	P2-G

- d. Verify electrical continuity for each "From-To" path with multi-meter.
- e. Crimp pins/sockets to cable wires.
- f. Assemble P1 and P2 connectors so keys/keyways and sockets align as indicated.

g. Mark sleeves in accordance with MIL-M-60903 as follows:

- 97403-13226E7023-2
- 120/208 VAC
- 3 PHASE
- 60 AMP

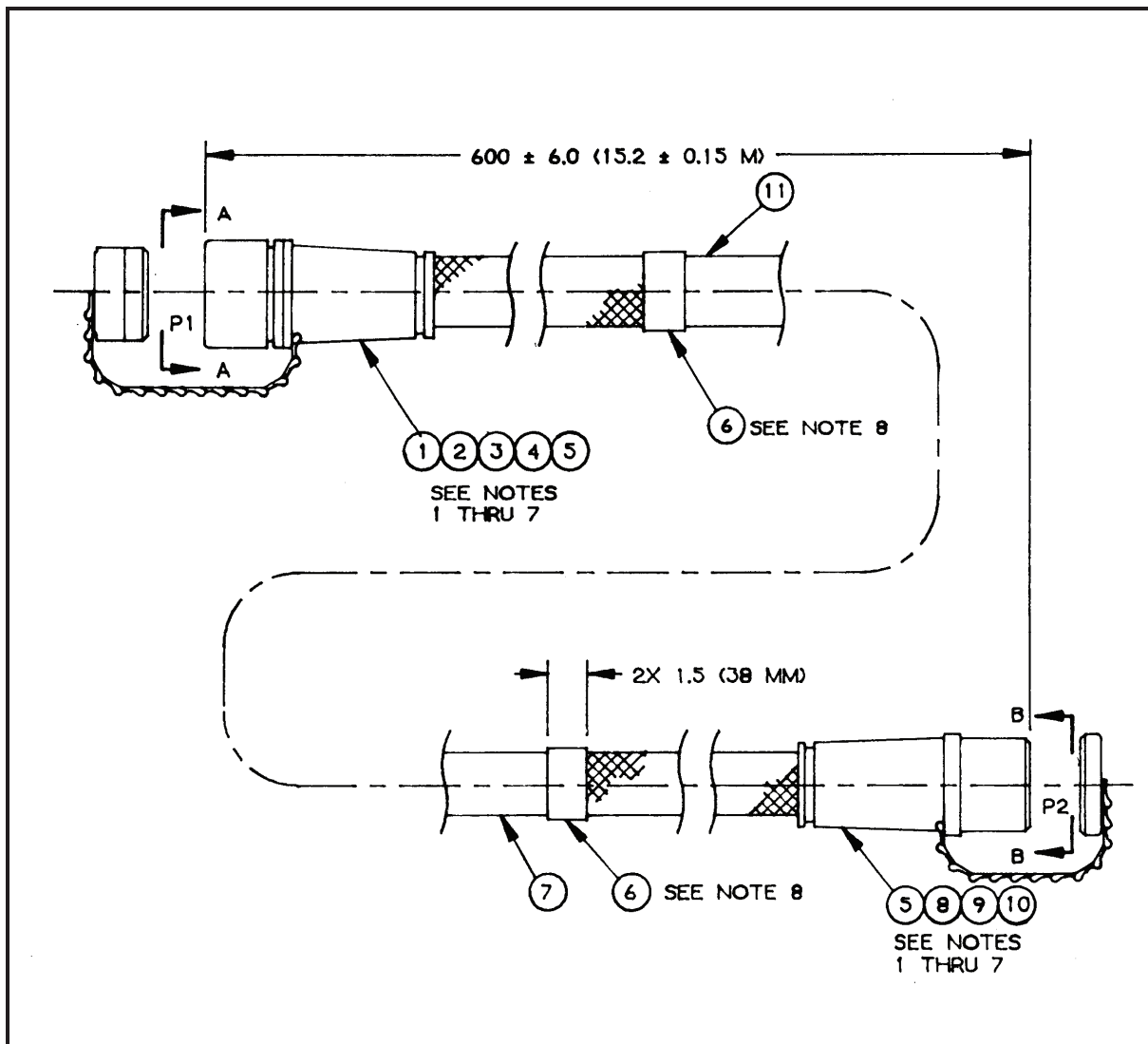

Figure F-21. Service/Feeder Cable, 200-Amp, 40/60-Amp (25-ft). (1 of 2)

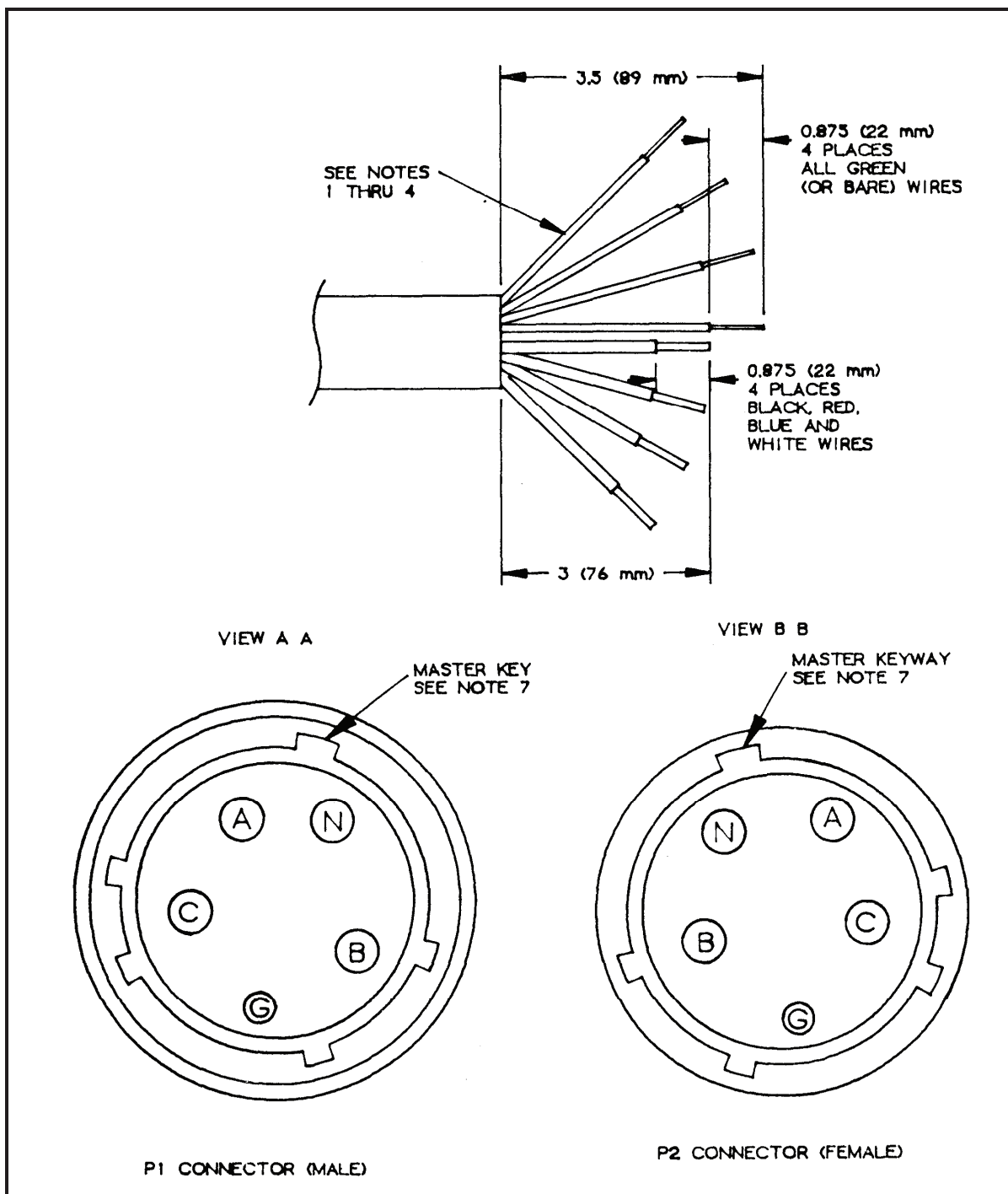

Figure F-21. Service/Feeder Cable, 200-Amp, 40/60-Amp (25-ft). (2 of 2)

WARNING

High voltage is present in this system. DISE and PDISE support equipment using 120/208 VAC. Do not rely on the color of the wire insulation for phase color-coding. The insulation on the wires inside the cable jacket may vary, depending on the supplier. Wires will be marked with colored tape to designate the phases. Perform a continuity test to verify correct phase designation in accordance with the colored tape.

NOTE

See WP 0029, 0030, and 0031 for valuable information regarding applicable cable and connector information. The callout numbers are considered applicable to the appropriate illustration number in each legend given.

F-22 (Service/Feeder Cable, 60-Amp, (100-ft)

Component Legend for Figure F-22

1. MS90556C32405P CONNECTOR, ELECTRICAL STRAIGHT PLUG (P1)
2. M39029/48-320 CONTACT, ELECTRICAL PIN (P1-A)
3. M39029/48-321 CONTACT, ELECTRICAL PIN (P1-N)
4. M39029/48-318 CONTACT, ELECTRICAL PIN (P1-G1, G2)
5. MS3348-6-8L REDUCER, ELECTRICAL CONTACT (P1-G, G2)
6. M23053/5-112-4 SLEEVING, INSULATION, HEAT SHRINK
7. CO-02HDF (2/4-2/8R) 1290 CABLE
8. MS90557C32405S CONNECTOR, ELECTRICAL RECEPTACLE (P2)
9. M39029/49-331 CONTACT, ELECTRICAL SOCKET (P2-A, N)
10. M39029/49-329 CONTACT, ELECTRICAL SOCKET (P2-G1, G2)
11. TAG, WARNING

- a. Cut and remove 3' of cable and 7/8' of wire insulation from cables as indicated. (WP 0029)
- b. Install P1 and P2 connectors on proper cable ends so colors and sockets match as indicated in Table 23:

Table 23. Service/Feeder Cable, 60-Amp, (100-ft)

COLOR	FROM	TO
BLACK	P1-A	P2-A
WHITE	P1-N	P2-N
GREEN (OR BARE)	P1-G1	P2-G1
GREEN (OR BARE)	P2-G2	P2-G2

- d. Verify electrical continuity for each "From-To" path with multi-meter.
- e. Crimp pins/sockets to cable wires.
- f. Assemble P1 and P2 connectors so keys/keyways and sockets align as indicated.

g. Mark sleeves in accordance with MIL-M-60903 as follows:

- 97403-13226E7022-1
- 120/208 VAC
- 3 PHASE
- 60 AMP

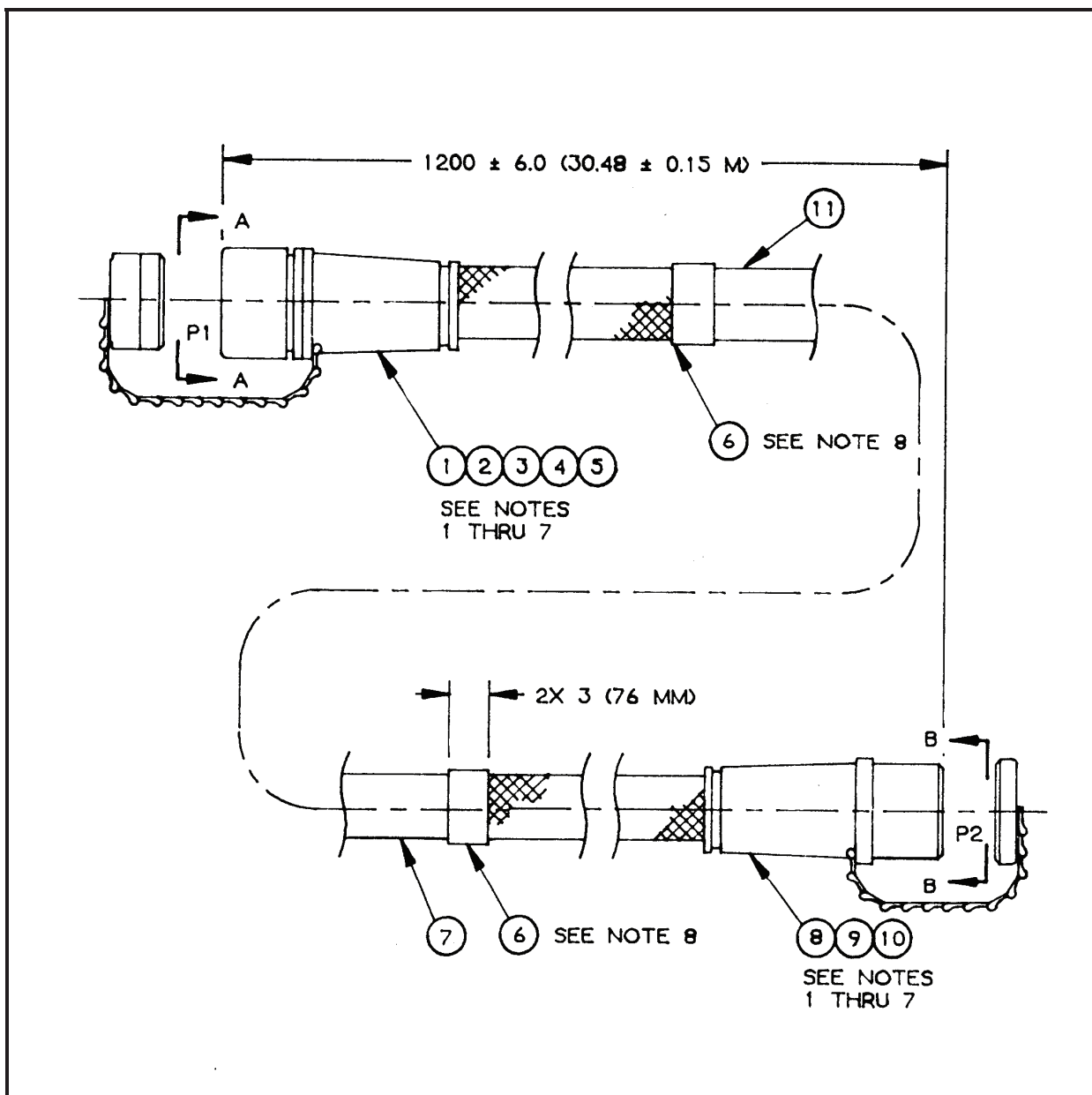

Figure F-22. Service/Feeder Cable, 60-Amp, (100-ft). (1 of 2)

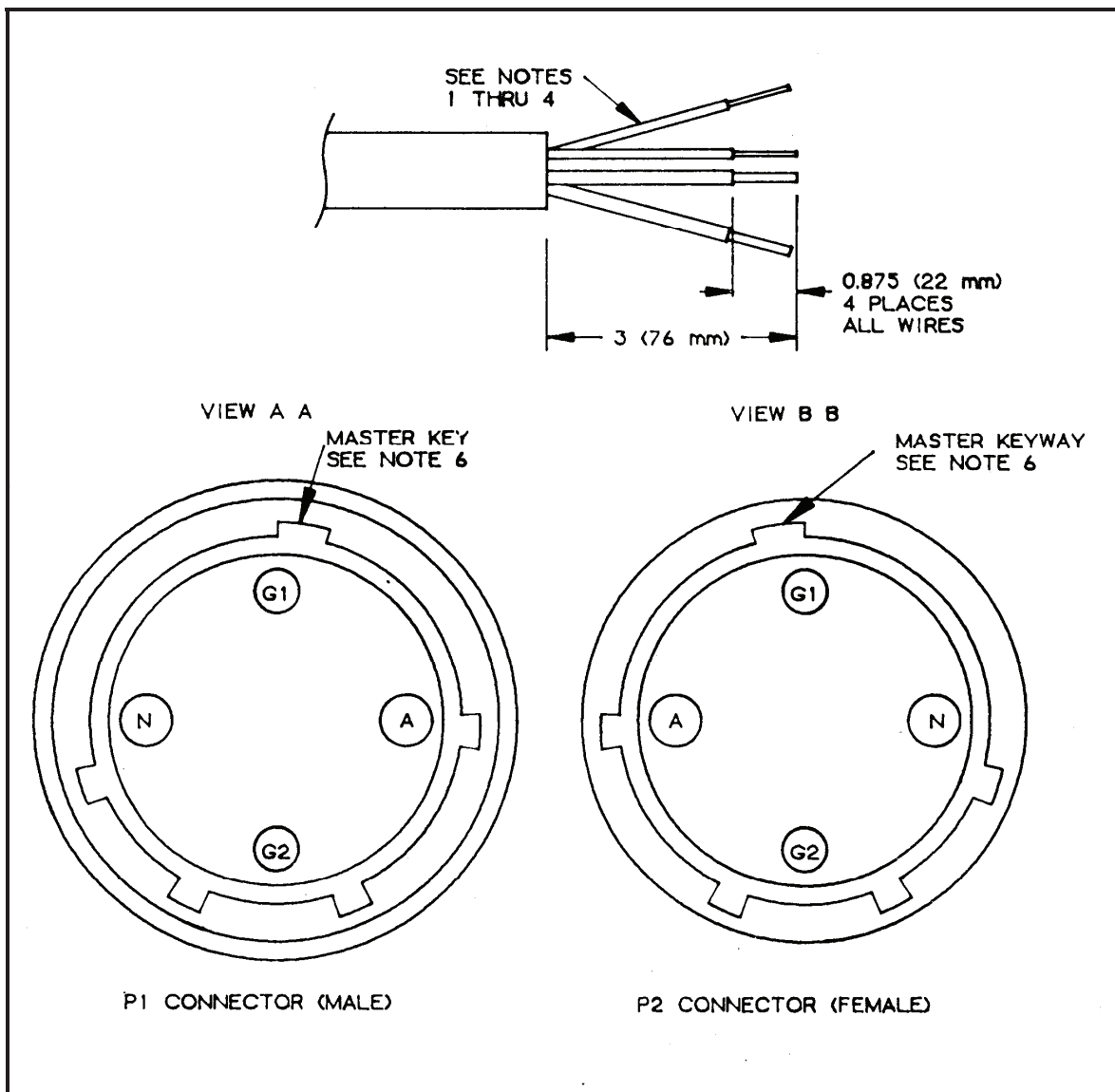

Figure F-22. Service/Feeder Cable, 60-Amp, (100-ft). (2 of 2)

WARNING

High voltage is present in this system. DISE and PDISE support equipment using 120/208 VAC. Do not rely on the color of the wire insulation for phase color-coding. The insulation on the wires inside the cable jacket may vary, depending on the supplier. Wires will be marked with colored tape to designate the phases. Perform a continuity test to verify correct phase designation in accordance with the colored tape.

NOTE

See WP 0029, 0030, and 0031 for valuable information regarding applicable cable and connector information. The callout numbers are considered applicable to the appropriate illustration number in each legend given.

F-23 (Extension Cable, 20-Amp, (15-ft)**Component Legend for Figure F-23**

1. MS3456W16-10P CONNECTOR, ELECTRICAL STRAIGHT PLUG (P1)
 2. M39029/48-290 CONTACT, ELECTRICAL PIN (P1-A, B, C)
 3. MS25042-16D COVER, ELECTRICAL CONNECTOR, STRAIGHT PLUG
 4. CO-03MGF (3/12) 0385 CABLE BLACK
 5. M23053/5-109-4 SLEEVING, INSULATION, HEAT SHRINK
 6. MS3451W16-10S CONNECTOR, ELECTRICAL, RECEPTACLE (P2)
 7. MS25043-16D COVER, ELECTRICAL, CONNECTOR, ELECTRICAL RECEPTACLE
 8. M39020/30-219 CONTACT, ELECTRICAL SOCKET (P2-A, B, C)
- a. Cut and remove 1/2' of cable and 3/8' of wire insulation from cables as indicated. (WP 0029)
 - b. Install P1 and P2 connectors on proper cable ends so colors and sockets match as indicated in Table 24:

Table 24. Extension Cable, 20-Amp, (15-ft)

COLOR	FROM	TO
BLACK	P1-A	P2-A
WHITE	P1-B	P2-B
GREEN	P1-C	P2-C

- d. Verify electrical continuity for each "From-To" path with multi-meter.
- e. Crimp pins/sockets to cable wires.
- f. Assemble P1 and P2 connectors so keys/keyways and pins/sockets align as indicated.
- g. Mark sleeves in accordance with MIL-M-60903 as follows:
 - 97403-13226E7032-1
 - 120/208 VAC
 - 3 PHASE
 - 20 AMP

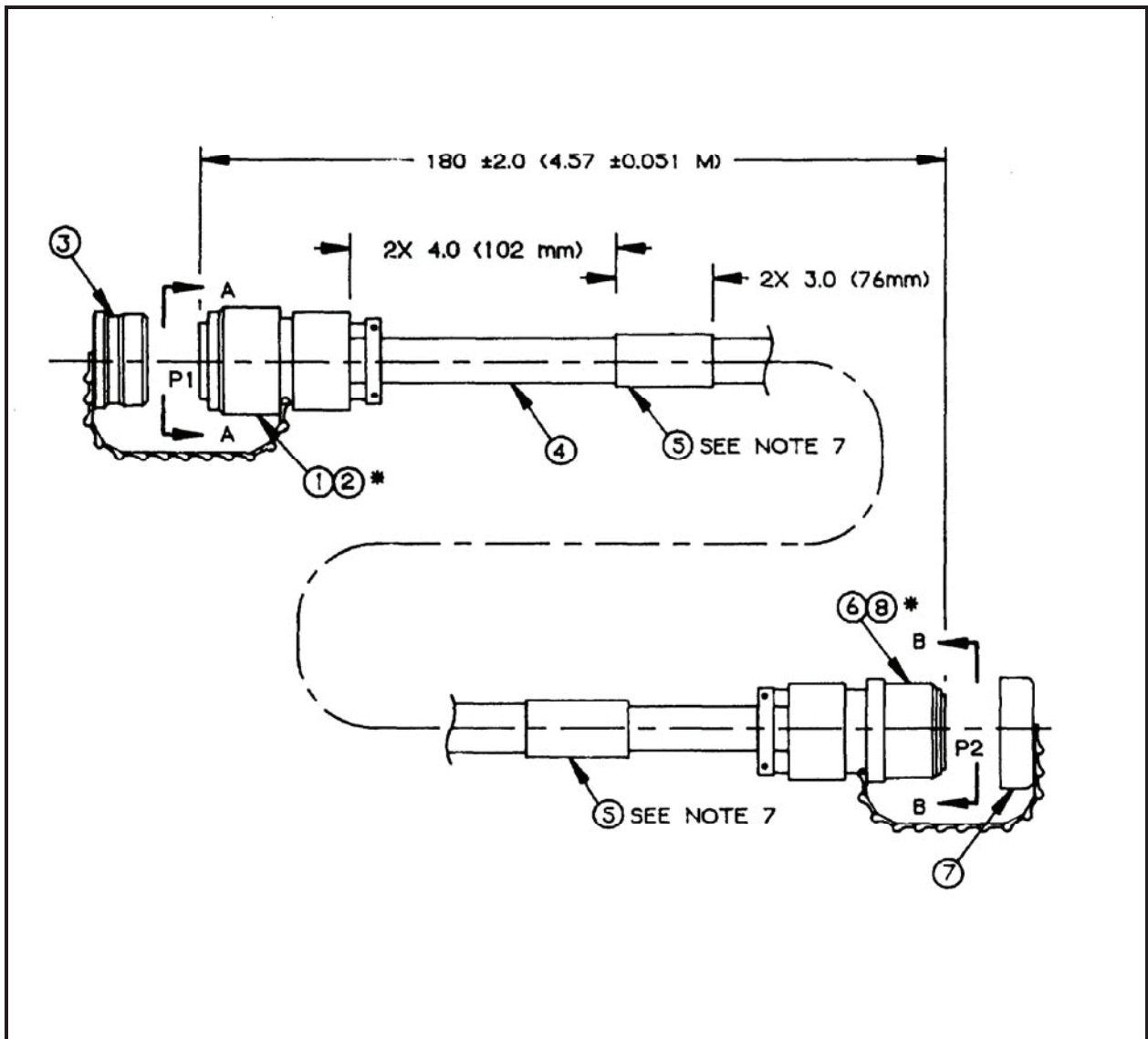

Figure F-23. Extension Cable, 20-Amp, (15-ft). (1 of 2)

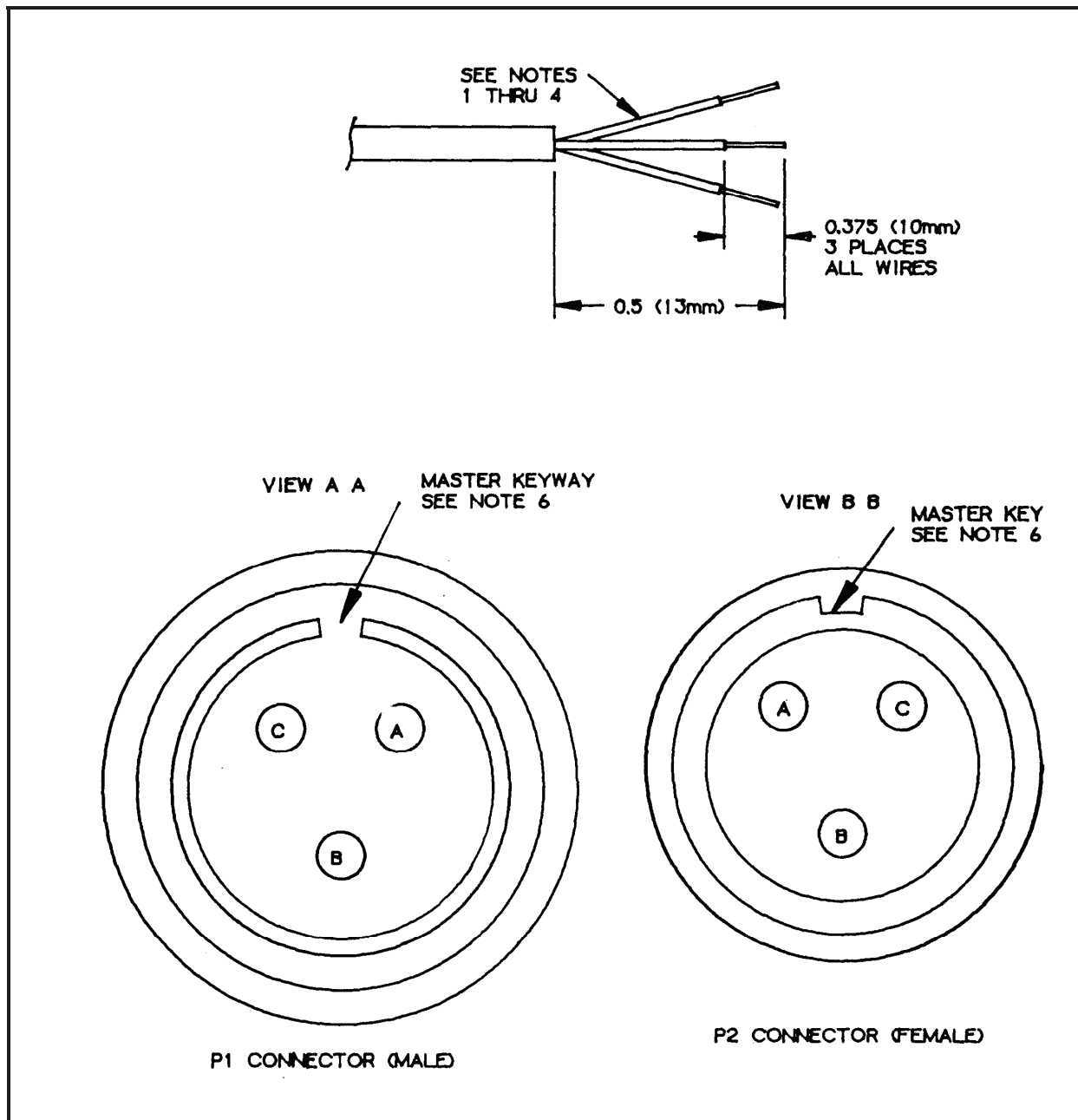

Figure F-23. Extension Cable, 20-Amp, (15-ft). (2 of 2)

WARNING

High voltage is present in this system. DISE and PDISE support equipment using 120/208 VAC. Do not rely on the color of the wire insulation for phase color-coding. The insulation on the wires inside the cable jacket may vary, depending on the supplier. Wires will be marked with colored tape to designate the phases. Perform a continuity test to verify correct phase designation in accordance with the colored tape.

NOTE

See WP 0029, 0030, and 0031 for valuable information regarding applicable cable and connector information. The callout numbers are considered applicable to the appropriate illustration number in each legend given.

F-24 (Extension Cable, 20-Amp, (25-ft)

Component Legend for Figure F-24

1. MS3456W16-10P CONNECTOR, ELECTRICAL STRAIGHT PLUG (P1)
2. M39029/48-290 CONTACT, ELECTRICAL PIN (P1-A, B, C)
3. MS25042-16D COVER, ELECTRICAL CONNECTOR, STRAIGHT PLUG
4. CO-03MGF (3/12) 0385 CABLE BLACK
5. M23053/5-109-4 SLEEVING, INSULATION, HEAT SHRINK
6. MS3451W16-10S CONNECTOR, ELECTRICAL, RECEPTACLE (P2)
7. MS25043-16D COVER, ELECTRICAL, CONNECTOR, ELECTRICAL RECEPTACLE
8. M39020/30-219 CONTACT, ELECTRICAL SOCKET (P2-A, B, C)

- a. Cut and remove 1/2' of cable and 3/8' of wire insulation from cables as indicated. (WP 0029)
- b. Install P1 and P2 connectors on proper cable ends so colors and sockets match as indicated in Table 25:

Table 25. Extension Cable, 20-Amp, (25-ft)

COLOR	FROM	TO
BLACK	P1-A	P2-A
WHITE	P1-B	P2-B
GREEN	P1-C	P2-C

- d. Verify electrical continuity for each "From-To" path with multi-meter.
- e. Crimp pins/sockets to cable wires.
- f. Assemble P1 and P2 connectors so keys/keyways and pins/sockets align as indicated.
- g. Mark sleeves in accordance with MIL-M-60903 as follows:

- 97403-13226E7032-2
- 120 VAC
- 3 PHASE
- 20 AMP

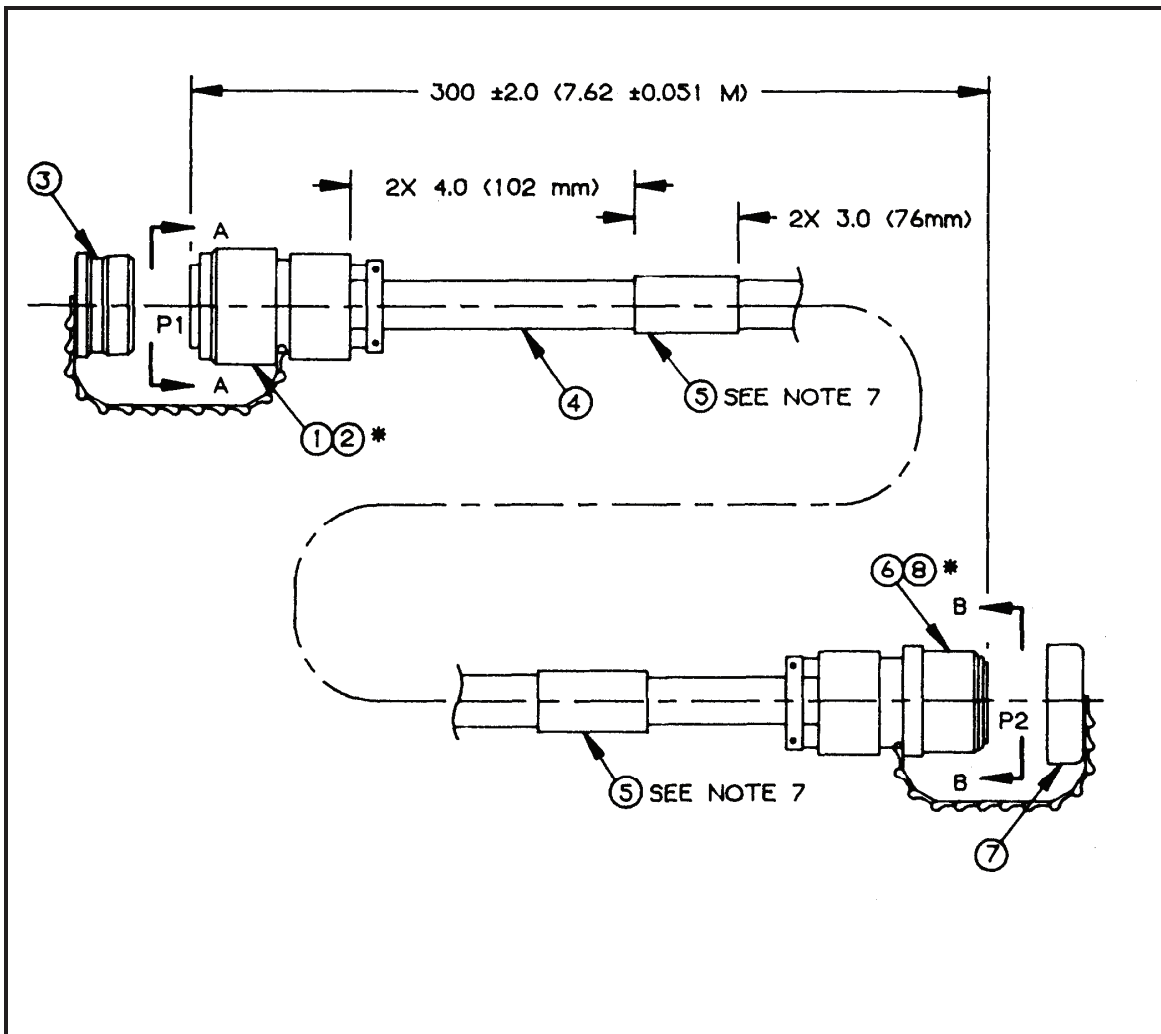

Figure F-24. Extension Cable, 20-Amp, (25-ft). (1 of 2)

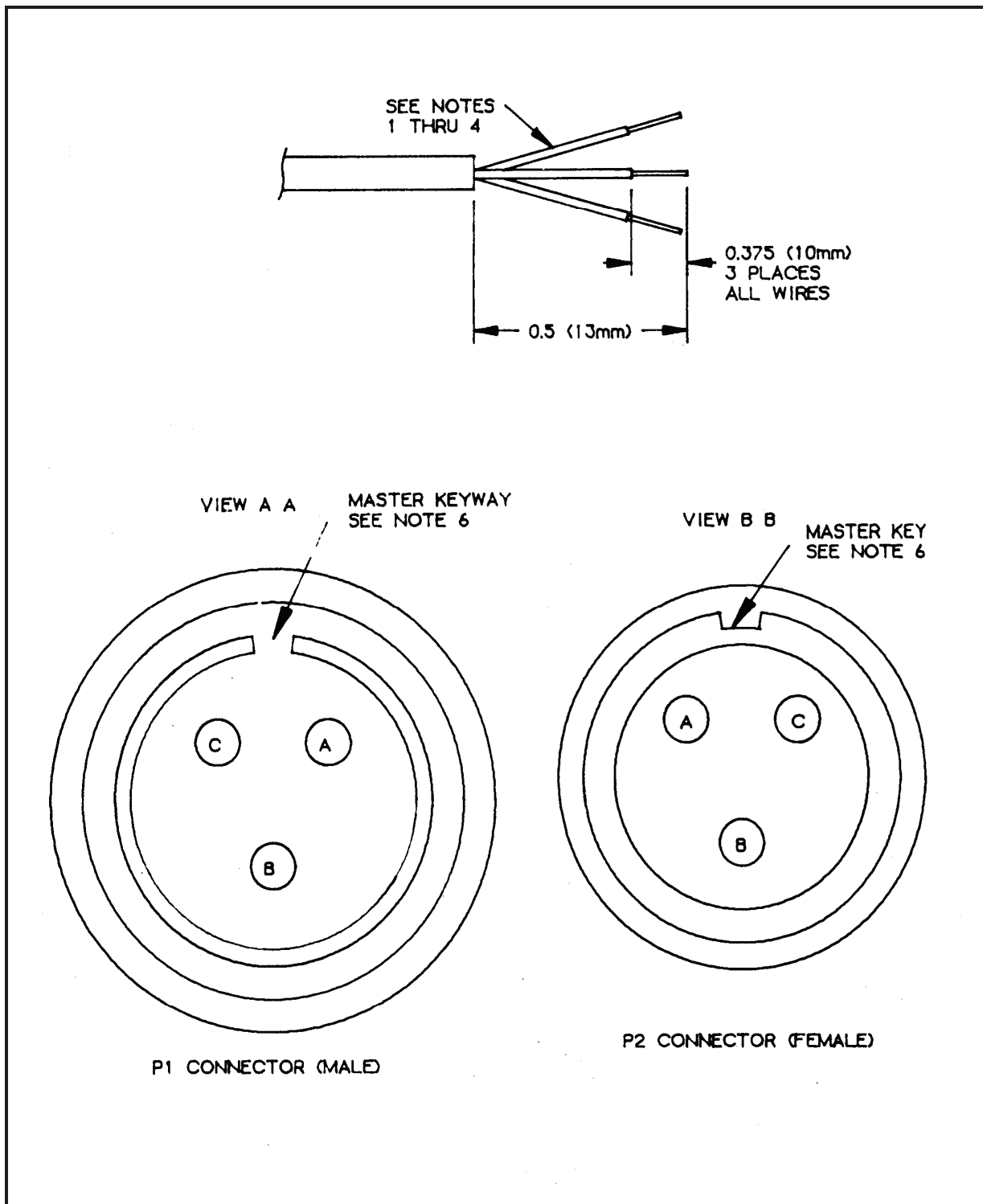

Figure F-24. Extension Cable, 20-Amp, (25-ft). (2 of 2)

WARNING

High voltage is present in this system. DISE and PDISE support equipment using 120/208 VAC. Do not rely on the color of the wire insulation for phase color-coding. The insulation on the wires inside the cable jacket may vary, depending on the supplier. Wires will be marked with colored tape to designate the phases. Perform a continuity test to verify correct phase designation in accordance with the colored tape.

NOTE

See WP 0029, 0030, and 0031 for valuable information regarding applicable cable and connector information. The callout numbers are considered applicable to the appropriate illustration number in each legend given.

F-25 (Extension Cable, 20-Amp, (50-ft)

Component Legend for Figure F-25

1. MS3456W16-10P CONNECTOR, ELECTRICAL STRAIGHT PLUG (P1)
2. M39029/48-290 CONTACT, ELECTRICAL PIN (P1-A, B, C)
3. MS25042-16D COVER, ELECTRICAL CONNECTOR, STRAIGHT PLUG
4. CO-03MGF (3/12) 0385 CABLE BLACK
5. M23053/5-109-4 SLEEVING, INSULATION, HEAT SHRINK
6. MS3451W16-10S CONNECTOR, ELECTRICAL, RECEPTACLE (P2)
7. MS25043-16D COVER, ELECTRICAL, CONNECTOR, ELECTRICAL RECEPTACLE
8. M39020/30-219 CONTACT, ELECTRICAL SOCKET (P2-A, B, C)

- a. Cut and remove 1/2' of cable and 3/8' of wire insulation from cables as indicated. (WP 0029)
- b. Install P1 and P2 connectors on proper cable ends so colors and sockets match as indicated in Table 26:

Table 26. Extension Cable, 20-Amp, (50-ft)

COLOR	FROM	TO
BLACK	P1-A	P2-A
WHITE	P1-B	P2-B
GREEN	P1-C	P2-C

- d. Verify electrical continuity for each "From-To" path with multi-meter.
- e. Crimp pins/sockets to cable wires.
- f. Assemble P1 and P2 connectors so keys/keyways and pins/sockets align as indicated.
- g. Mark sleeves in accordance with MIL-M-60903 as follows:

- 97403-13226E7032-4
- 120 VAC
- 3 PHASE
- 20 AMP

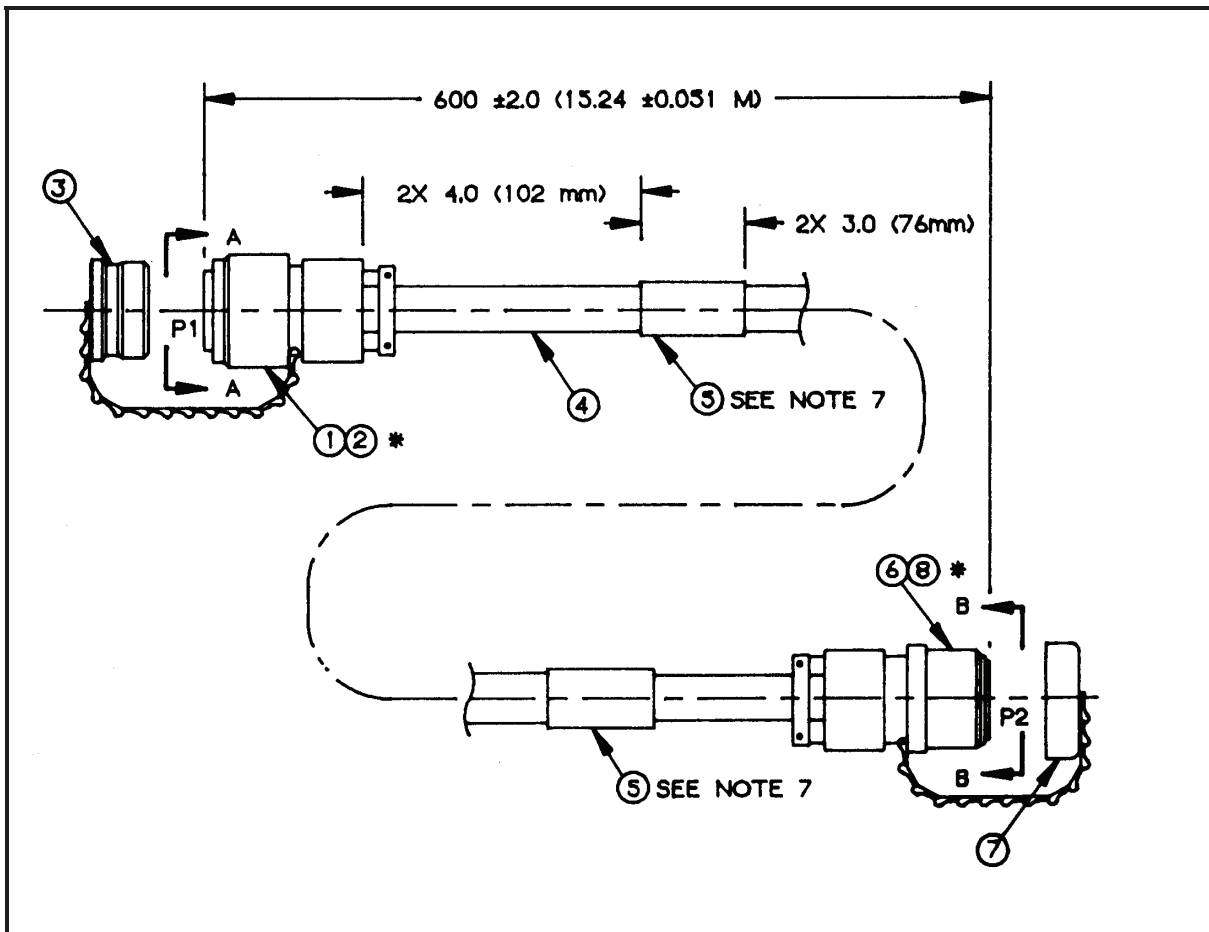

Figure F-25. Extension Cable, 20-Amp, (50-ft). (1 of 2)

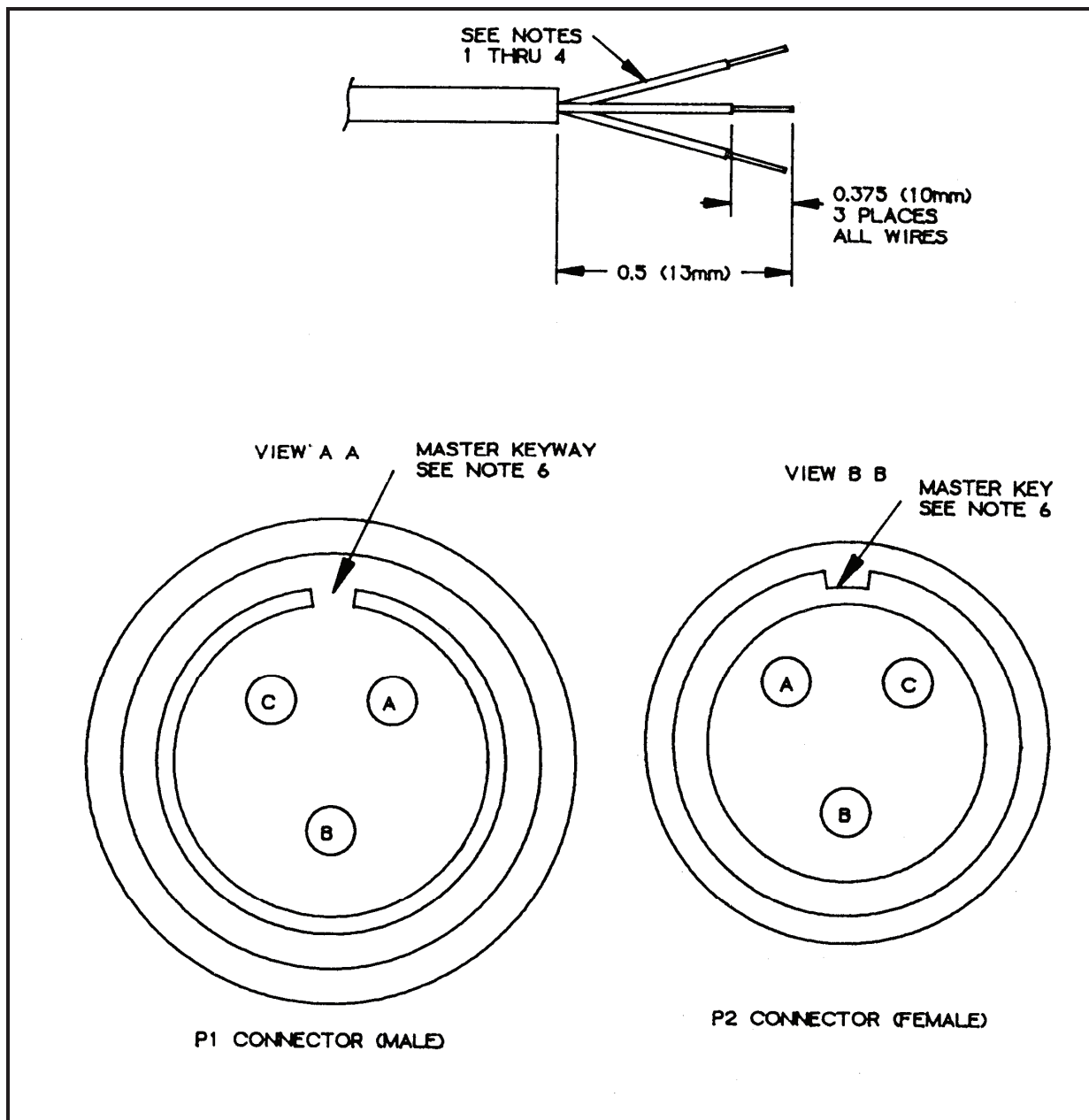

Figure F-25. Extension Cable, 20-Amp, (50-ft). (2 of 2)

NOTE

See WP 0029, 0030, and 0031 for valuable information regarding applicable cable and connectors. The callout numbers are considered applicable to the appropriate illustration number in each legend given.

F-26 (Feeder Center Input Connector Assembly, M200 A/P (PDISE), 200-Amp (J1))**Component Legend for Figure F-26**

1. MS90564-11C COVER, ELECTRICAL CONNECTOR
2. MS90558C52413P CONNECTOR, ELECTRICAL
3. GASKET
4. M39029/48-327 CONTACT, ELECTRICAL PIN (A, B, C)
5. M39029/48-328 CONTACT, ELECTRICAL PIN (N)
6. M5086/2-04-9 WIRE, ELECTRICAL (A, B, C, N)
7. M5086/2-4-9 WIRE, ELECTRICAL (G1, G2, G3, G4)
8. M39029/48-322 CONTACT, ELECTRICAL PIN (G1, G2, G3, G4)
9. MS3349 REDUCER, CONTACT ELECTRICAL WIRE, NICKEL (G1, G2, G3, G4)

- a. Cut and remove 4 1/6' of wire insulation as indicated. (WP 0029)
- b. Crimp electrical contact to wires for positions as noted in Table 27 below:

Table 27. Feeder Center Input Connector Assembly, M200 A/P (PDISE), 200-Amp (J1)

ITEM POSITION	FIGURE/ITEM NO.	WIRE SIZE	WIRE LENGTH
A	4 and 6	4/0	19.75 (501.7 MM)
B	4 and 6	4/0	21.00 (533.4 MM)
C	4 and 6	4/0	21.00 (533.4 MM)
N	5 and 6	4/0	11.75 (298.5 MM)
G1	7, 8, and 9	4/0	17.75 (450.9 MM)
G2	7, 8, and 9	4/0	17.75 (450.9 MM)
G3	7, 8, and 9	4/0	18.25 (463.6 MM)
G4	7, 8, and 9	4/0	18.00 (457.2 MM)

- c. Electrical connector (Figure F-26, Item 2) is furnished with the following:

- Cover (Item 1)
- Gasket (Item 3)
- Electrical contact sockets (Items 4, 5, and 8)

- d. Assemble connector so keys/keyways and sockets align as indicated.

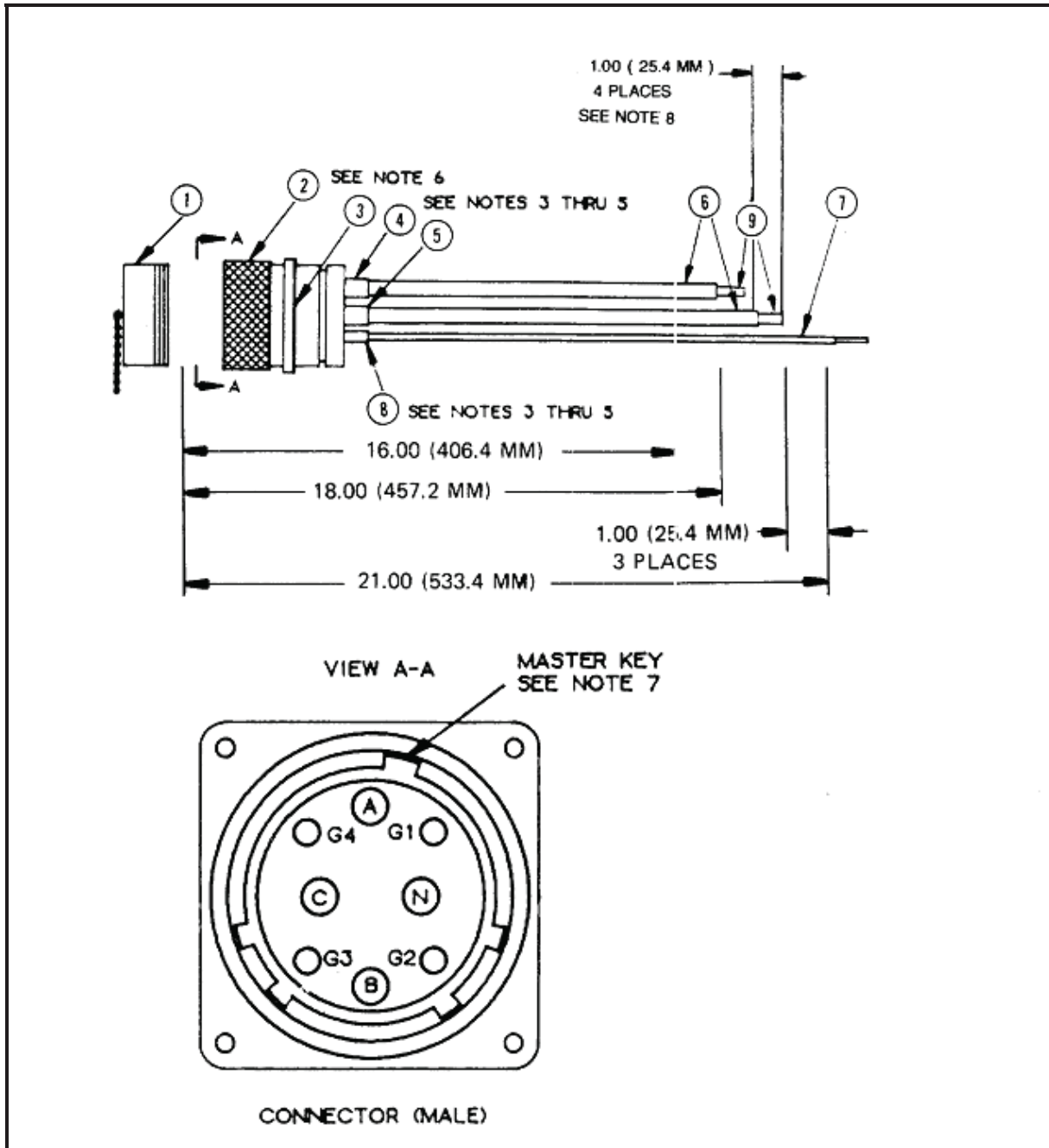

Figure F-26. Feeder Center Input Connector Assembly, M200 A/P (PDISE), 200-Amp (J1)

NOTE

See WP 0029, 0030, and 0031 for valuable information regarding applicable cable and connectors. The callout numbers are considered applicable to the appropriate illustration number in each legend given.

F-27 (Feeder Center Input Connector, M100 A/P (PDISE), 100-Amp (J1))**Component Legend for Figure F-27**

1. MS90564-7C COVER, ELECTRICAL CONNECTOR
2. MS9055844413P CONNECTOR, ELECTRICAL
3. GASKET
4. M39029/48-323 CONTACT, ELECTRICAL PIN (A, B, C)
5. M39029/48-324 CONTACT, ELECTRICAL PIN (N)
6. M5086/2-1-9 WIRE, ELECTRICAL (A, B, C, N)
7. M5086/2-6-9 WIRE, ELECTRICAL (G1, G2, G3, G4)
8. M39029/48-319 CONTACT, ELECTRICAL PIN (G1, G2, G3, G4)

- a. Cut and remove 3 1/2 'of wire insulation as indicated. (WP 0029)
- b. Crimp electrical contact to wires for positions as noted in Table 28 below:

Table 28. Feeder Center Input Connector, M100 A/P (PDISE), 100-Amp (J1)

ITEM POSITION	FIGURE/ITEM NO.	WIRE SIZE	WIRE LENGTH
A	4 AND 6	1	24.50 (633.3 MM)
B	4 AND 6	1	25.00 (635.0 MM)
C	4 AND 6	1	24.75 (628.7 MM)
N	5 AND 6	1	7.50 (190.5 MM)
G1	7, 8, AND 9	6	11.50 (292.1 MM)
G2	7, 8, AND 9	6	11.62 (295.1 MM)
G3	7, 8, AND 9	6	10.00 (254.0 MM)
G4	7, 8, AND 9	6	10.75 (273.1 MM)

- c. Electrical connector (Figure F-27, Item 2) is furnished with the following:
 - Cover (Item 1)
 - Gasket (Item 3)
 - Electrical contact sockets (Items 4, 5, and 8)
- d. Assemble connector so keys/keyways and sockets align as indicated.

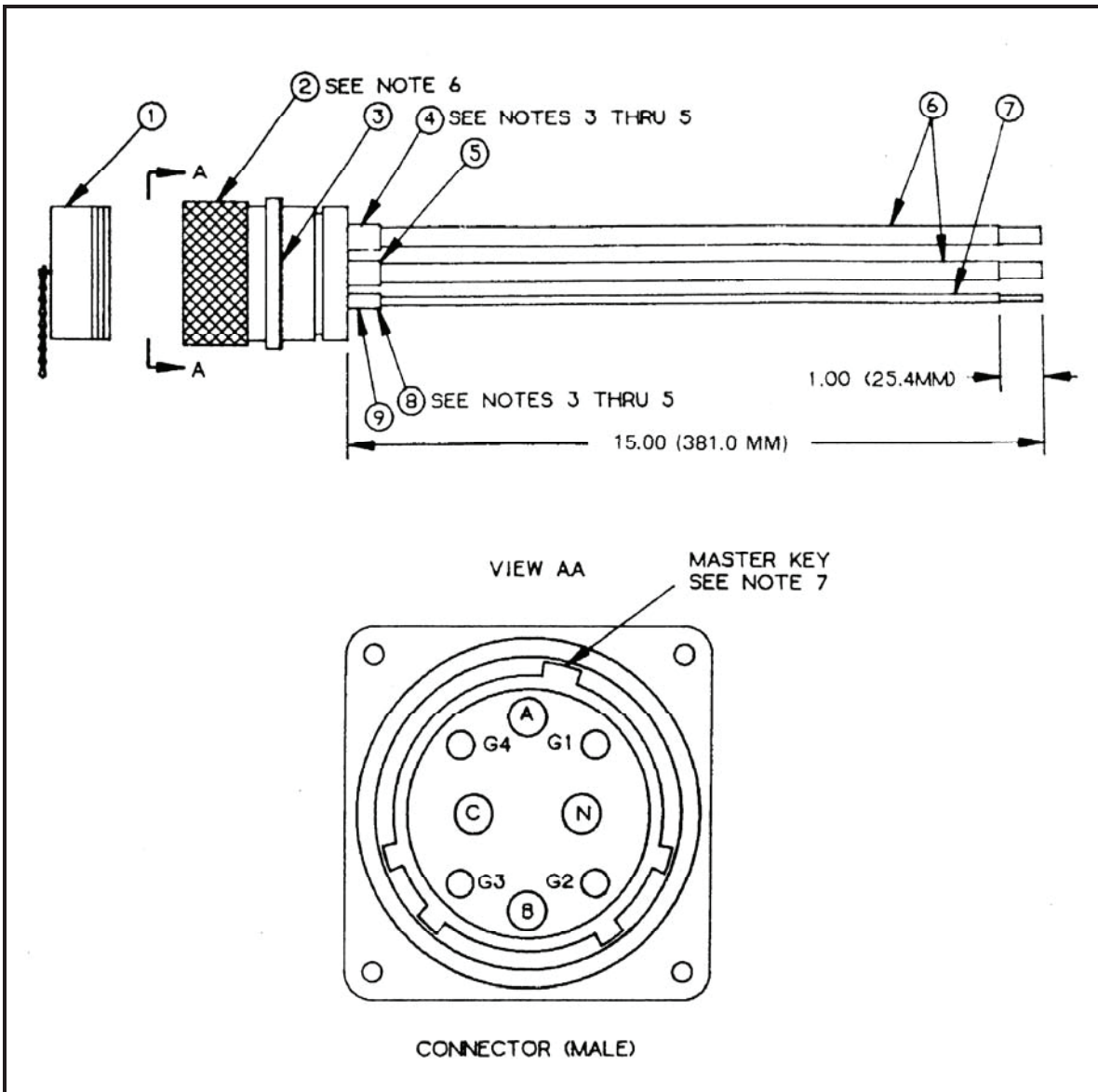

Figure F-27. Feeder Center Input Connector, M100 A/P (PDISE), 100-Amp (J1)

NOTE

See WP 0029, 0030, and 0031 for valuable information regarding applicable cable and connectors. The callout numbers are considered applicable to the appropriate illustration number in each legend given.

**F-28 (Feeder Center Output Connector Assemblies, M200 A/P (PDISE), 100-Amp (J4, J5, J11)
(Feeder Center Output Connector Assembly, M100 A/P (PDISE), 100-Amp (J2))**

Component Legend for Figure F-28

1. MS90563-7C COVER, ELECTRICAL CONNECTOR
2. MS90555C444135 CONNECTOR, ELECTRICAL RECEPTACLE
3. GASKET
4. M39029/49-333 CONTACT, ELECTRICAL SOCKET (A, B, C, N)
5. M5086/2-1-9 WIRE, ELECTRICAL (A, B, C, N)
6. M5086/2-6-9 WIRE, ELECTRICAL (G1, G2, G3, G4)
7. M39029/49-330 CONTACT, ELECTRICAL PIN (G1,G2,G3,G4)

- a. Cut and remove 3 ½' of wire insulation as indicated. (WP 0029)
- b. Crimp electrical contact to wires for positions as noted in Tables 29 thru 32 below:

Table 29. M200 A/P (PDISE), (100-Amp) Output Connector Assembly (J4)

POSITION	ITEM NO.	WIRE SIZE	WIRE LENGTH
A	4 and 5	1	21.50 (546.1 MM)
B	4 and 5	1	21.00 (533.4 MM)
C	4 and 5	1	21.00 (533.4 MM)
N	5 and 5	1	8.50 (215.9 MM)
G1	7, 8, and 9	6	8.25 (209.6 MM)
G2	7, 8, and 9	6	8.00 (203.2 MM)
G3	7, 8, and 9	6	5.75 (146.1 MM)
G4	7, 8, and 9	6	7.00 (177.8 MM)

Table 30. M200 A/P (PDISE), (100-Amp) Output Connector Assembly (J5)

POSITION	FIGURE/ITEM NO.	WIRE SIZE	WIRE LENGTH
A	4 and 5	1	9.62 (244.3 MM)
B	4 and 5	1	11.25 (285.8 MM)
C	4 and 5	1	10.00 (254.0 MM)
N	5 and 5	1	6.50 (165.1MM)
G1	7, 8, and 9	6	11.50 (292.1 MM)
G2	7, 8, and 9	6	12.00 (304.8 MM)
G3	7, 8, and 9	6	10.75 (273.1 MM)
G4	7, 8, and 9	6	12.00 (304.8 MM)

Table 31. M200 A/P (PDISE), (100-Amp) Output Connector Assembly (J11)

POSITION	FIGURE/ITEM NO.	WIRE SIZE	WIRE LENGTH
A	4 and 5	1	9.50 (241.3 MM)
B	4 and 5	1	10.88 (276.4 MM)
C	4 and 5	1	10.00 (254.0 MM)
N	5 and 5	1	5.62 (142.7 MM)
G1	7, 8, and 9	6	11.62 (295.1 MM)
G2	7, 8, and 9	6	11.00 (279.4 MM)
G3	7, 8, and 9	6	10.50 (266.7 MM)
G4	7, 8, and 9	6	11.62 (295.1 MM)

Table 32. M100 A/P (PDISE), (100-Amp) Output Connector Assembly (J11)

POSITION	FIGURE/ITEM NO.	WIRE SIZE	WIRE LENGTH
A	4 and 5	1	14.50 (371.3 MM)
B	4 and 5	1	19.00 (482.6 MM)
C	4 and 5	1	22.00 (558.8 MM)
N	5 and 5	1	11.00 (279.4 MM)
G1	7, 8, and 9	6	10.00 (254.0 MM)
G2	7, 8, and 9	6	10.00 (254.0 MM)
G3	7, 8, and 9	6	8.50 (215.9 MM)
G4	7, 8, and 9	6	8.75 (222.3 MM)

c. Electrical connector (Figure F-28, Item 2) is furnished with the following:

- Cover (Item 1)
- Gasket (Item 3)
- Electrical contact sockets (Items 4 and 7)

d. Assemble connector so keys/keyways and sockets align as indicated.

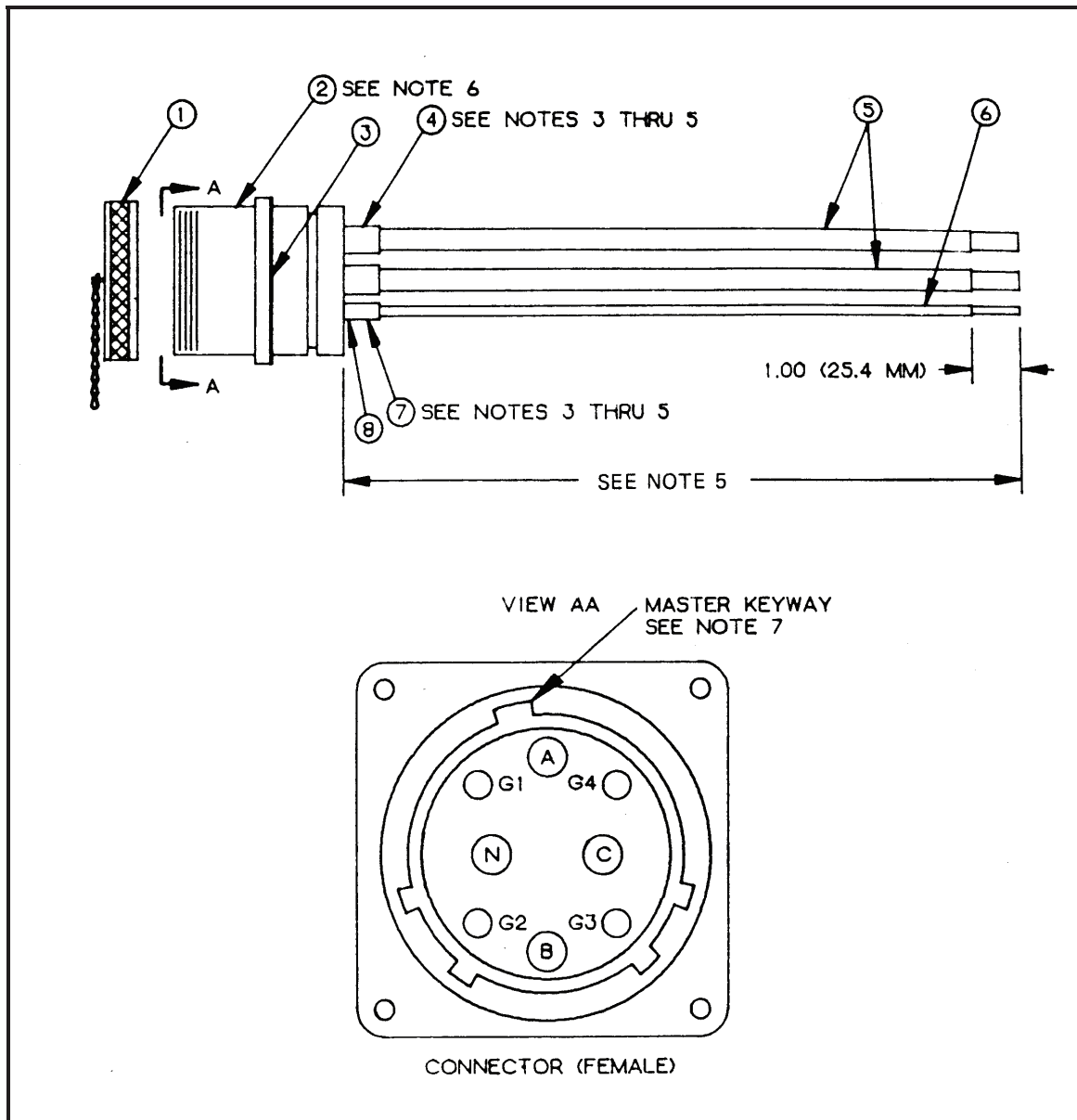

Figure F-28. PDISE 100-Amp, Output Connector Assembly.

NOTE

See WP 0029, 0030, and 0031 for valuable information regarding applicable cable and connectors. The callout numbers are considered applicable to the appropriate illustration number in each legend given.

F-29 (Distribution Center Input Connector Assembly, M40 A/P (PDISE), 40-Amp (J1))**Component Legend for Figure F-29**

1. M590564-3C COVER, ELECTRICAL CONNECTOR
2. MS90558C32413P CONNECTOR, ELECTRICAL
3. GASKET
4. M39029/48-320 CONTACT, ELECTRICAL PIN (A, B, C)
5. M39029/48-321 CONTACT, ELECTRICAL PIN (N)
6. M5086/2-4-9 WIRE, ELECTRICAL (A, B, C, N)
7. M5086/2-6-9 WIRE, ELECTRICAL (G)
8. M39029/48-318 CONTACT, ELECTRICAL PIN (G)

- a. Cut and remove 3 1/2' of wire insulation as indicated. (WP 0029)
- b. Crimp electrical contact to wires for positions as noted in Table 33 below:

Table 33. Distribution Center Input Connector Assembly, M40 A/P (PDISE), 40-Amp (J1)

POSITION	FIGURE/ITEM NO.	WIRE SIZE	WIRE LENGTH
A	4 and 5	4	28.50 (723.9 MM)
B	4 and 5	4	29.00 (736.6 MM)
C	4 and 5	4	29.50 (749.3 MM)
N	5 and 8	4	16.00 (406.4 MM)
G	6, 7, and 9	6	16.00 (406.4 MM)

- c. Electrical connector (Figure F-29, Item 2) is furnished with the following:

- Cover (Item 1)
- Gasket (Item 3)
- Electrical contact sockets (Items 4, 7, and 8)

- d. Assemble connector so keys/keyways and sockets align as indicated.

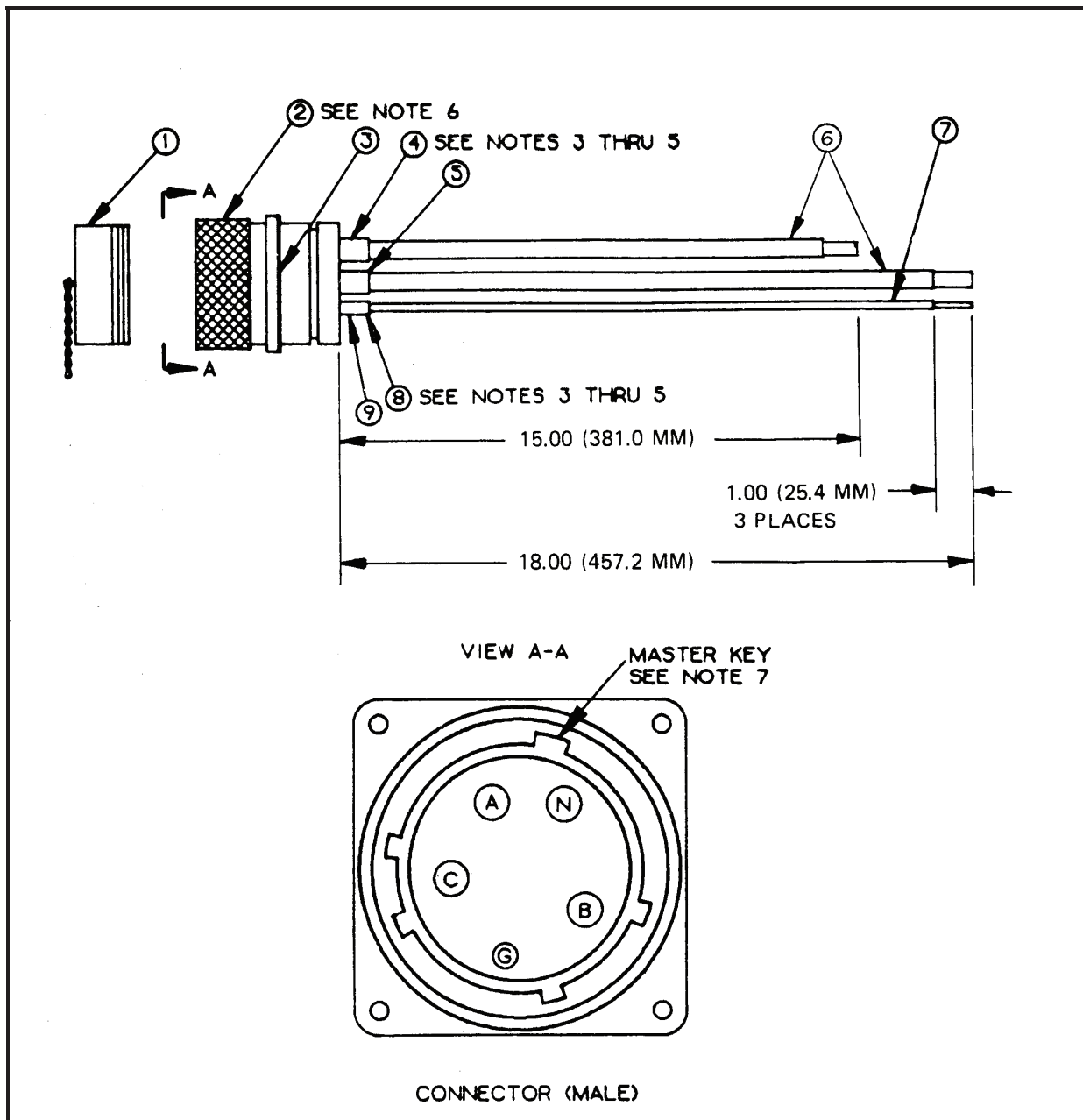

Figure F-29. Distribution Center Input Connector Assembly, M40 A/P (PDISE), 40-Amp (J1)

NOTE

See WP 0029, 0030, and 0031 for valuable information regarding applicable cable and connectors. The callout numbers are considered applicable to the appropriate illustration number in each legend given.

F-30 (Feeder Center Output Connector Assemblies, M200 A/P (PDISE), 40/60-Amp (J7, J8, J9, J10) (Feeder Center Output Connector Assemblies, M100 A/P (PDISE), 40/60-Amp (J3, J4, J5, J6) (Distribution Center Output Connector, M40 A/P (PDISE), 40/60-Amp (J2)

Component Legend for Figure F-30

1. MS90563-3C COVER, ELECTRICAL CONNECT OR
2. MS90555C32413S CONNECTOR, ELECTRICAL RECEPTACLE
3. GASKET
4. M39029/49-331 CONTACT, ELECTRICAL SOCKET (A, B, C, N)
5. M5086/2-4-9 WIRE, ELECTRICAL (A, B, C, N)
6. M5086/2-6-9 WIRE, ELECTRICAL (G)
7. M39029/49-329 CONTACT, ELECTRICAL SOCKET (G)

- a. Cut and remove 3 ½' of wire insulation as indicated. (WP 0029)
- b. Crimp electrical contact to wires for positions as noted in Tables 34 thru 38 below:

Table 34. M200 A/P (PDISE), (40/60-Amp) Output Connector Assembly (J7 and J9)

POSITION	ITEM NO.	WIRE SIZE	WIRE LENGTH
A	4 and 5	4	23 (584.2 MM)
B	4 and 5	4	23 (584.2 MM)
C	4 and 5	4	23 (584.2 MM)
N	4 and 5	4	12 (304.8 MM)
G	6, 7, and 8	6	18 (457.2 MM)

Table 35. M200 A/P (PDISE), (40/60-Amp) Output Connector Assembly (J8 and J10)

POSITION	ITEM NO.	WIRE SIZE	WIRE LENGTH
A	4 and 5	4	15 (381.0 MM)
B	4 and 5	4	15 (381.0 MM)
C	4 and 5	4	15 (381.0 MM)
N	5 and 8	4	12 (304.8 MM)
G	6, 7, and 9	6	15 (381.0 MM)

Table 36. M100 A/P (PDISE), (40/60-Amp) Output Connector Assembly (J3 and J5)

POSITION	ITEM NO.	WIRE SIZE	WIRE LENGTH
A	4 and 5	4	25 (635.0 MM)
B	4 and 5	4	25 (635.0 MM)
C	4 and 5	4	25 (635.0 MM)
N	5 and 8	4	12 (304.8 MM)
G	6, 7, and 9	6	15 (381.0 MM)

Table 37. M100 A/P (PDISE), (40/60-Amp) Output Connector Assembly (J4 and J6)

POSITION	ITEM NO.	WIRE SIZE	WIRE LENGTH
A	4 and 5	4	14 (355.6 MM)
B	4 and 5	4	14 (355.6 MM)
C	4 and 5	4	14 (355.6 MM)
N	5 and 8	4	14 (355.6 MM)
G	6, 7, and 9	6	15 (381.0 MM)

Table 38. M40 A/P (PDISE), (40/60-Amp) Output Connector Assembly (J2)

POSITION	ITEM NO.	WIRE SIZE	WIRE LENGTH
A	4 and 5	4	18 (457.2 MM)
B	4 and 5	4	18 (457.2 MM)
C	4 and 5	4	18 (457.2 MM)
N	5 and 8	4	18 (457.2 MM)
G	6, 7, and 9	6	18 (457.2 MM)

c. Electrical connector (Figure F-30, Item 2) is furnished with the following:

- Cover (Item 1)
- Gasket (Item 3)
- Electrical contact sockets (Items 4 and 7)

d. Assemble connector so keys/keyways and sockets align as indicated.

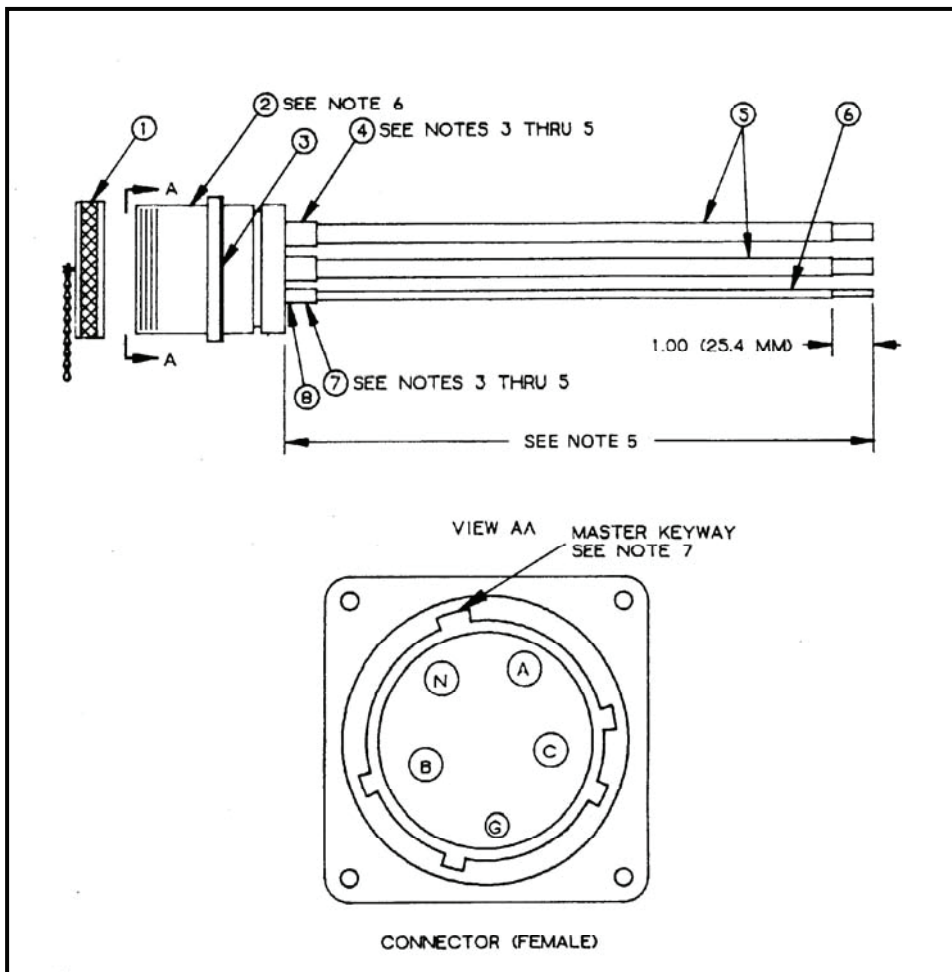

Figure F-30. PDISE 40/60-Amp, Output Connector Assembly.

NOTE

See WP 0029, 0030, and 0031 for valuable information regarding applicable cable and connectors. The callout numbers are considered applicable to the appropriate illustration number in each legend given.

F-31 (Distribution Center Input Connector, M60 A/P (PDISE), 60-Amp (J1))

Component Legend for Figure F-31

1. MS90564-3C COVER, ELECTRICAL CONNECTOR
2. MS90558C32405P CONNECTOR, ELECTRICAL RECEPTACLE
3. GASKET
4. M39029/48-318 CONTACT, ELECTRICAL PIN (G1, G2)
5. M5086/2-6-9 WIRE, ELECTRICAL (G1, G2)
6. M5086/2-4-9 WIRE, ELECTRICAL (A, N)
7. M39029/48-320 CONTACT, ELECTRICAL PIN (A)
8. M39029/48-321 CONTACT, ELECTRICAL PIN (N)

- a. Cut and remove 3' of wire insulation as indicated. (WP 0029)
- b. Crimp electrical contact to wires for positions as noted in Table 39 below:

Table 39. Distribution Center Input Connector, M60 A/P (PDISE), 60-Amp (J1)

POSITION	ITEM NO.	WIRE SIZE	WIRE LENGTH
A	6 and 7	4	21.00 (533.4 MM)
N	6 and 8	4	6.00 (152.4 MM)
G1	4, 5, and 9	6	18.00 (457.2 MM)
G2	4, 5, and 9	6	18.00 (457.2 MM)

- c. Electrical connector (Figure F-31, Item 2) is furnished with the following:
 - Cover (Item 1)
 - Gasket (Item 3)
 - Electrical contact sockets (Items 4, 7, and 8)
- d. Assemble connector so keys/keyways and sockets align as indicated.

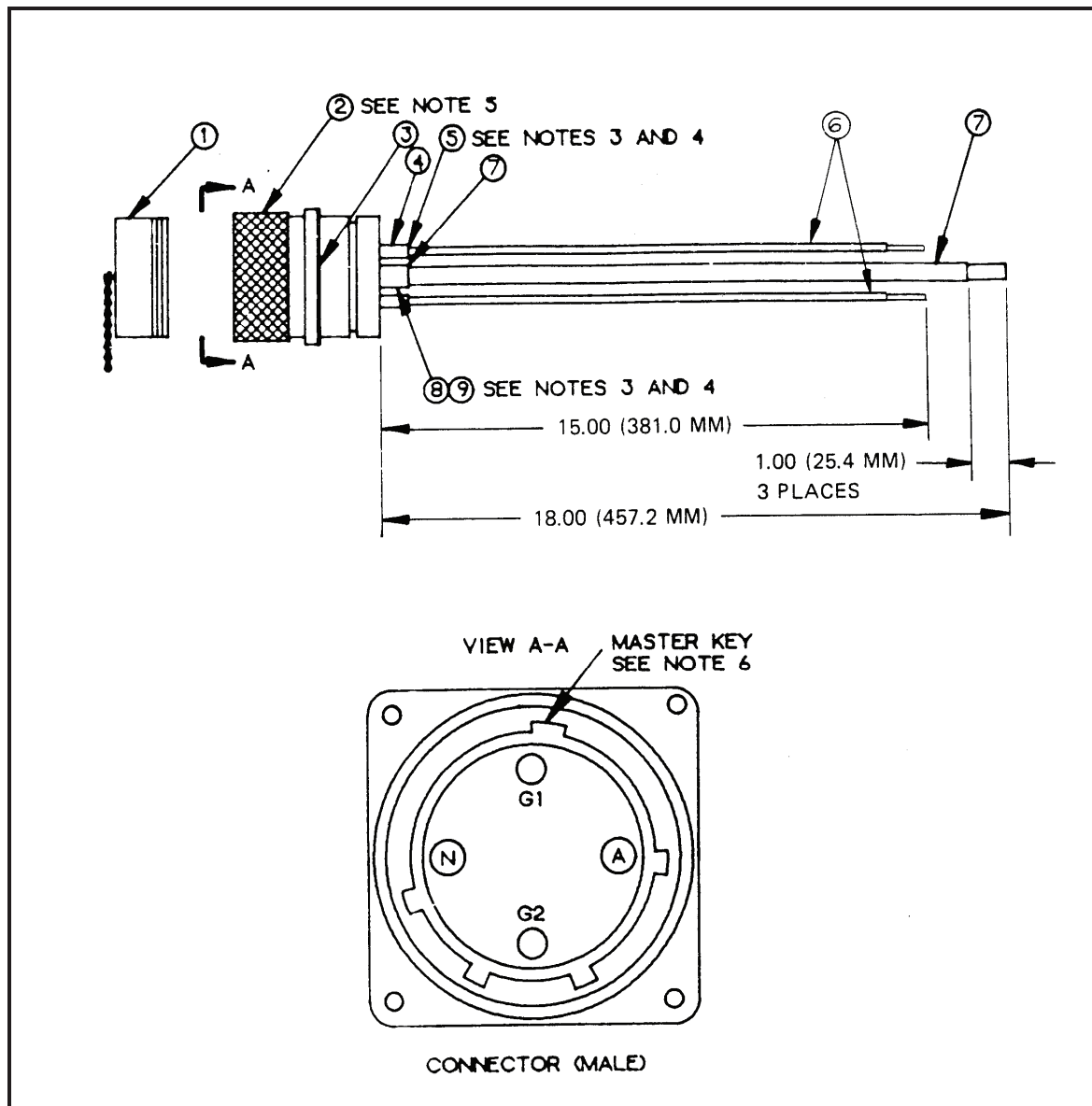

Figure F-31. Distribution Center Input Connector, M60 A/P (PDISE), 60-Amp (J1)

NOTE

See WP 0029, 0030, and 0031 for valuable information regarding applicable cable and connectors. The callout numbers are considered applicable to the appropriate illustration number in each legend given.

F-32 (Distribution Center Output Connector Assembly, M60 A/P (PDISE), 60-Amp (J2))

Component Legend for Figure F-32

1. MS90564-3C COVER, ELECTRICAL CONNECTOR
2. MS90558C32405P CONNECTOR, ELECTRICAL RECEPTACLE
3. GASKET
4. M39029/49-329 CONTACT, ELECTRICAL PIN (G1, G2)
5. M5086/2-6-9 WIRE, ELECTRICAL (G1, G2)
6. M5086/2-4-9 WIRE, ELECTRICAL (A, N)
7. M39029/49-331 CONTACT, ELECTRICAL PIN (A, N)

- a. Cut and remove 3' of wire insulation as indicated. (WP 0029)
- b. Crimp electrical contact to wires for positions as noted in Table 40 below:

Table 40. Distribution Center Output Connector Assembly, M60 A/P (PDISE), 60-Amp (J2)

POSITION	ITEM NO.	WIRE SIZE	WIRE LENGTH
A	7 and 8	4	14.50 (368.3 MM)
N	7 and 8	4	14.00 (355.6 MM)
G1	4, 5, and 6	6	6.00 (152.4 MM)
G2	4, 5, and 6	6	6.00 (152.4 MM)

c. Electrical connector (Figure F-32, Item 2) is furnished with the following:

- Cover (Item 1)
- Gasket (Item 3)
- Electrical contact sockets (Items 5 and 8)

d. Assemble connector so keys/keyways and sockets align as indicated.

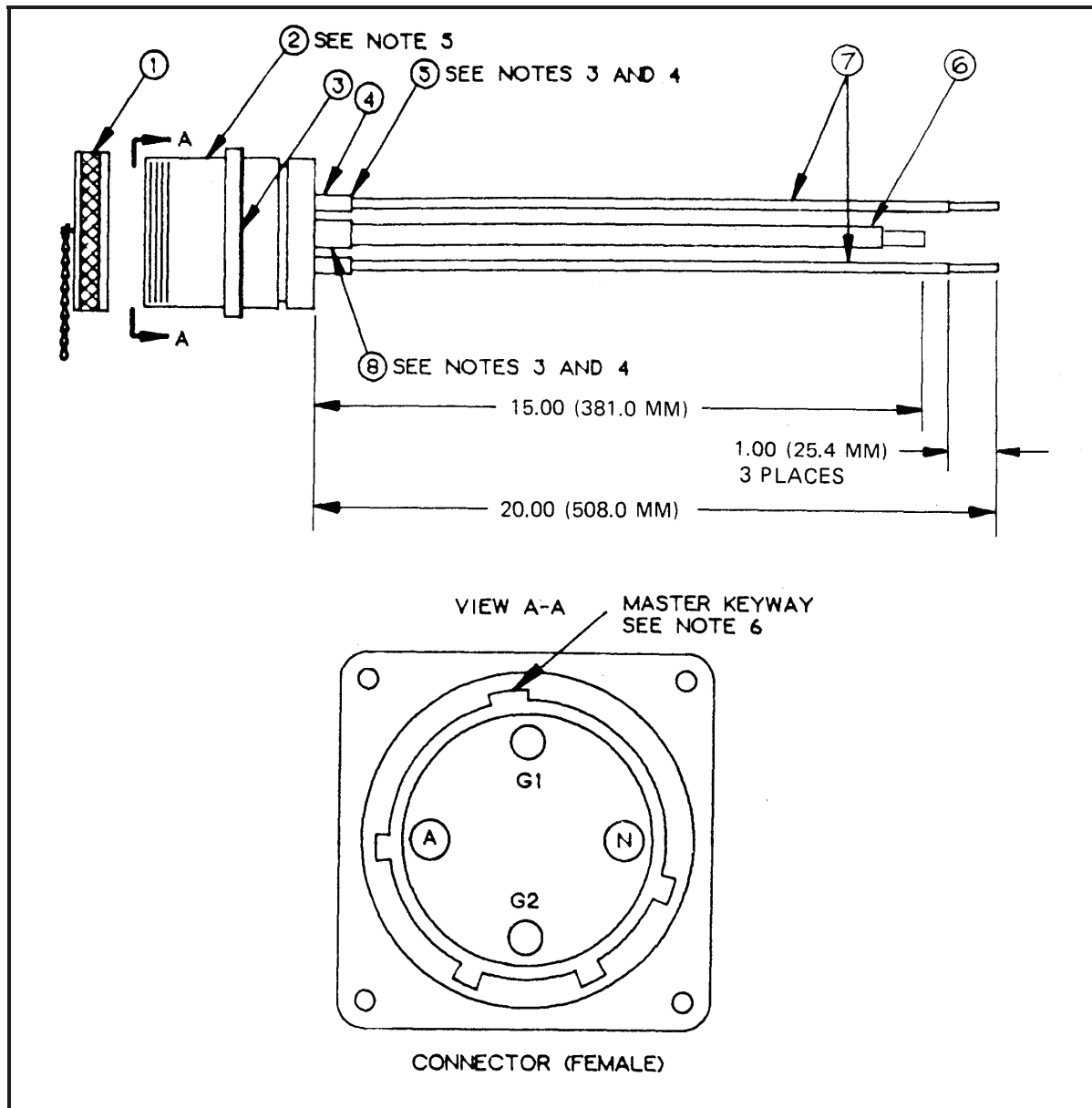

Figure F-32. Distribution Center Output Connector Assembly, M60 A/P (PDISE), 60-Amp (J2)

NOTE

See WP 0029, 0030, and 0031 for valuable information regarding applicable cable and connectors. The callout numbers are considered applicable to the appropriate illustration number in each legend given.

**F-33 (Distribution Center Output Connector Assemblies, M40 A/P (PDISE), 20-Amp (J3 thru J14)
(Distribution Center Output Connector Assemblies, M60 A/P (PDISE), 20-Amp (J3 thru J8))**

Component Legend for Figure F-33

1. MS25043-16D COVER, ELECTRICAL CONNECTOR
2. MS3402D16-10S CONNECTOR, ELECTRICAL RECEPTACLE
3. GASKET
4. M5086/2-12-9 WIRE, ELECTRICAL (A, B, C)
5. M39029/30-219 SOCKET, ELECTRICAL CONTACT (A, B, C)

- a. Cut and remove ½' of wire insulation as indicated. (WP 0029)
- b. Crimp electrical contact to wires for positions as noted in Table 41 thru 44 below:

Table 41. M-40 A/P, 20-Amp Output Connector Assemblies (J3, J5, J7, J9, J11 and J13)

POSITION	ITEM NO.	WIRE SIZE	WIRE LENGTH
A	4 and 5	12	20 (508.0 MM)
B	4 and 5	12	12 (304.8 MM)
C	4 and 5	12	15 (381.0 MM)

Table 42. M-40 A/P, 20-Amp Output Connector Assemblies (J4, J6, J8, J10, J12 AND J14)

POSITION	ITEM NO.	WIRE SIZE	WIRE LENGTH
A	4 and 5	12	10 (254.0 MM)
B	4 and 5	12	15 (381.0 MM)
C	4 and 5	12	12 (304.8 MM)

Table 43. M-60 A/P, 20-Amp Output Connector Assemblies (J3, J5, AND J7)

POSITION	ITEM NO.	WIRE SIZE	WIRE LENGTH
A	4 and 5	12	18 (457.2 MM)
B	4 and 5	12	9 (228.6 MM)
C	4 and 5	12	14 (355.6 MM)

Table 44. M-60 A/P, 20-Amp Output Connector Assemblies (J4, J6 AND J8)

POSITION	ITEM NO.	WIRE SIZE	WIRE LENGTH
A	4 and 5	12	9 (228.6 MM)
B	4 and 5	12	14 (355.6 MM)
C	4 and 5	12	8 (203.2 MM)

c. Electrical connector (Figure F-33, Item 2) is furnished with the following:

- Cover (Item 1)
- Gasket (Item 3)
- Electrical contact sockets (Items 5)

d. Assemble connector so keys/keyways and sockets align as indicated.

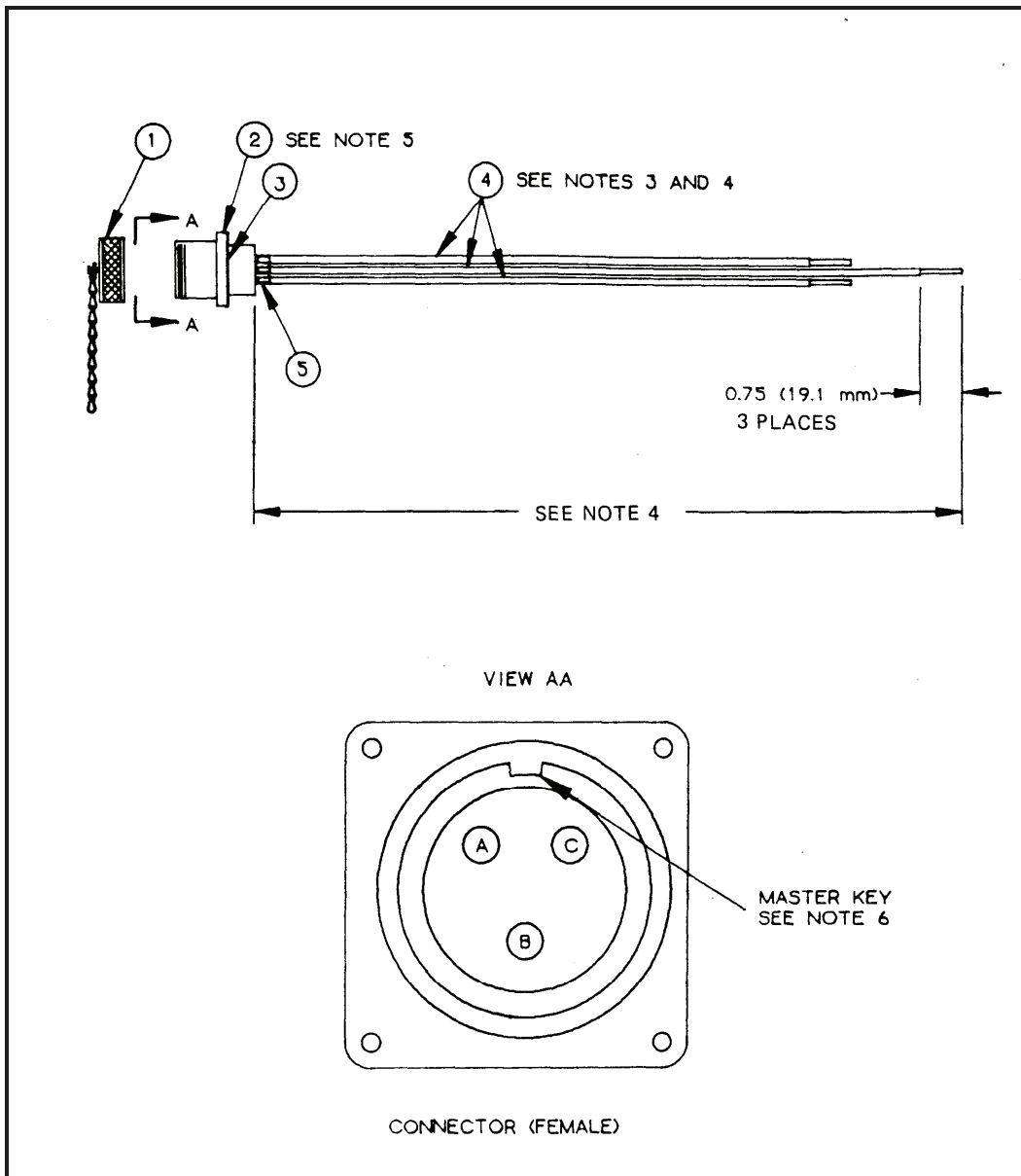

Figure F-33. M40/60 A/P (PDISE) 20-Amp, Output Connector Assemblies.

NOTE

See WP 0029, 0030, and 0031 for valuable information regarding applicable cable and connectors. The callout numbers are considered applicable to the appropriate illustration number in each legend given.

**F-34 (Feeder Center Output Connector Assembly, M200 A/P (PDISE), 20-Amp (J6)
(Feeder Center Output Connector Assemblies, M100 A/P (PDISE), 20-Amp (J7 and J8))**

Component Legend for Figure F-34

1. MS25043-16D COVER, ELECTRICAL CONNECTOR
2. MS3402D16-10S CONNECTOR, ELECTRICAL RECEPTACLE
3. GASKET
4. M5086/2-12-9 WIRE, ELECTRICAL (A, B, C)
5. M39029/30-219 SOCKET, ELECTRICAL CONTACT (A, B, C)

- a. Cut and remove 1/2' of wire insulation as indicated. (WP 0029)
- b. Crimp electrical contact to wires for positions as noted in Table 45 and 46 below:

Table 45. Feeder Center Output Connector Assembly M200 A/P (PDISE) 20-Amp, (J6)

POSITION	ITEM NO.	WIRE SIZE	WIRE LENGTH
A	4 and 5	12	12 (304.8 MM)
B	4 and 5	12	12 (304.8 MM)
C	4 and 5	12	10 (254.0 MM)

Table 46. Feeder Center Output Connector Assembly, M100 A/P (PDISE) 20-Amp, (J8)

POSITION	ITEM NO.	WIRE SIZE	WIRE LENGTH
A	4 and 5	12	14 (355.6 MM)
B	4 and 5	12	14 (355.6 MM)
C	4 and 5	12	14 (355.6 MM)

- c. Electrical connector (Figure F-34, Item 2) is furnished with the following:

- Cover (Item 1)
- Gasket (Item 3)
- Electrical contact sockets (Item 5)

- d. Assemble connector so keys/keyways and sockets align as indicated.

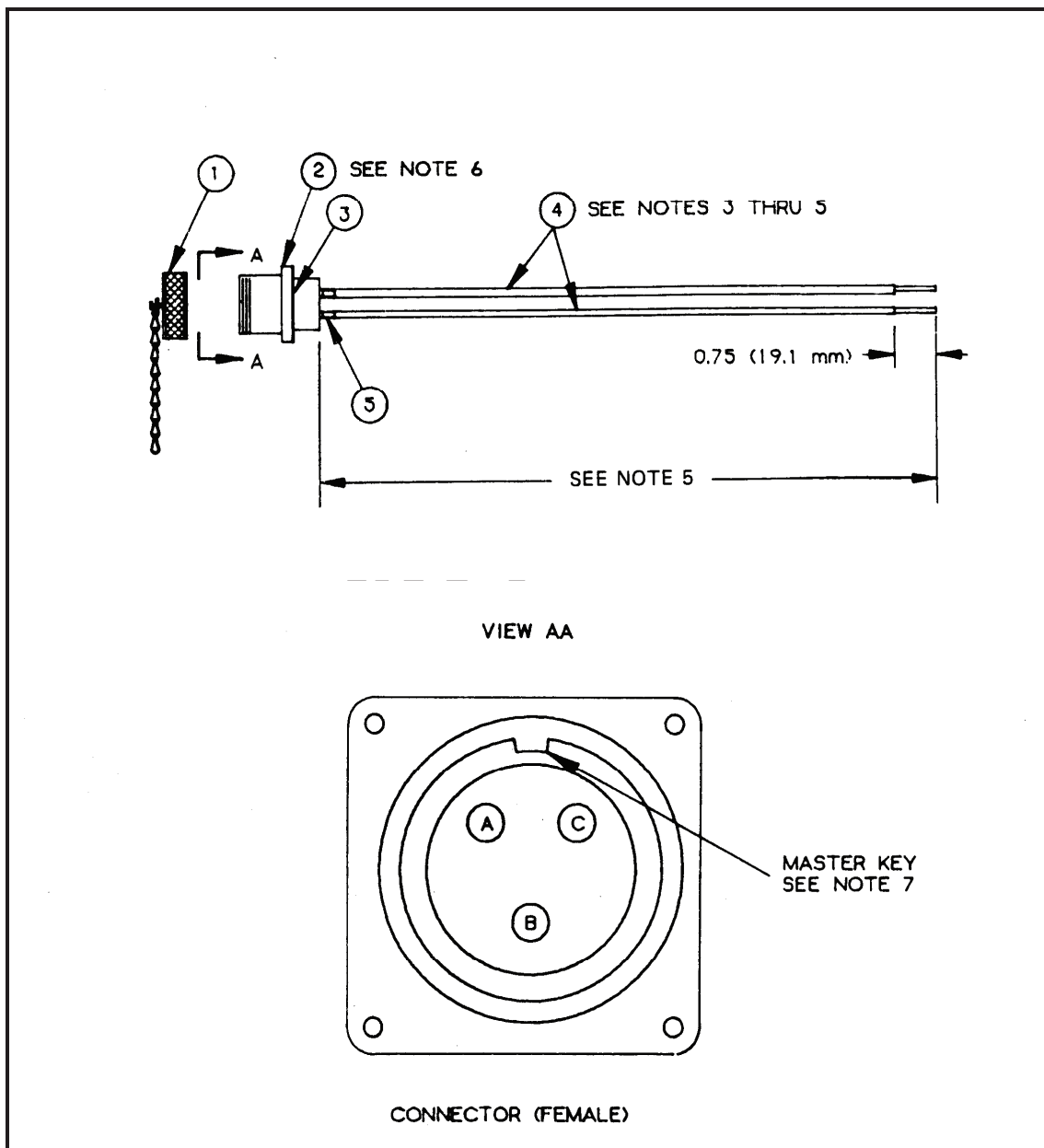

Figure F-34. Feeder Center Output Connector Assemblies, M200/100 A/P (PDISE) 20-Amp.

NOTE

See WP 0029, 0030, and 0031 for valuable information regarding applicable cable and connectors. The callout numbers are considered applicable to the appropriate illustration number in each legend given.

F-35 (Feeder Center Output Connector Assembly, M100 A/P (PDISE) 20-Amp, (J7))

Component Legend for Figure F-35

1. MS25043-16D COVER, ELECTRICAL CONNECTOR
2. MS3402D16-10S CONNECTOR, ELECTRICAL RECEPTACLE
3. GASKET
4. M5086/2-12-9 WIRE, ELECTRICAL (A, B, C)
5. M39029/30-219 SOCKET, ELECTRICAL CONTACT (A, B, C)

- a. Cut and remove wire insulation as indicated. (WP 0029)
- b. Crimp electrical contact to wires for positions as noted in Table 47 below:

Table 47. Feeder Center Output Connector Assembly, M100 A/P (PDISE) 20-Amp, (J7)

POSITION	ITEM NO.	WIRE SIZE	WIRE LENGTH
A	4 and 5	12	25 (635.0 MM)
B	4 and 5	12	15 (381.0 MM)
C	4 and 5	12	15 (381.0 MM)

- c. Electrical connector (Figure F-35, Item 2) is furnished with the following:

- Cover (Item 1)
- Gasket (Item 3)
- Electrical contact sockets (Item 5)

- d. Assemble connector so keys/keyways and sockets align as indicated.

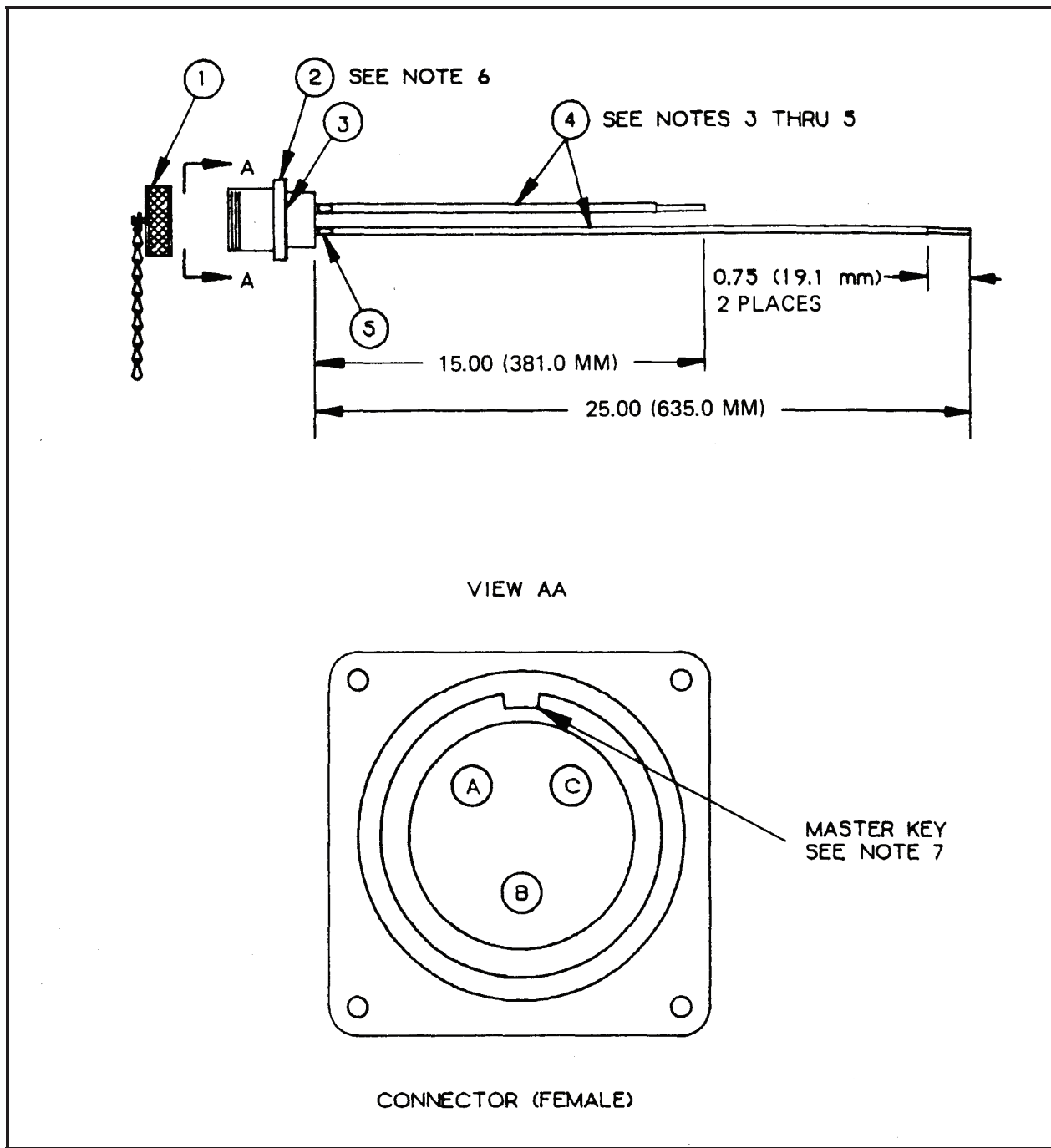

Figure F-35. Feeder Center Output Connector Assembly, M100 A/P (PDISE) 20-Amp, (J7)

END OF WORK PACKAGE

**SUPPORTING INFORMATION
DISE/PDISE EQUIPMENT
TORQUE LIMITS**

GENERAL

This section provides general torque limits for screws used on the DISE and PDISE systems. Special torque limits are indicated in the maintenance procedures for applicable components. The general torque limits given in this appendix shall be used when specific torque limits are not indicated in the maintenance procedure. These general torque limits cannot be applied to screws that retain rubber components. The rubber components will be damaged before the correct torque limit is reached. If a special torque limit is not given in the maintenance instructions, tighten the screw or nut until it touches the metal bracket; then tighten it one more turn.

TORQUE LIMITS.

Table 1 lists torque limits for circuit breaker lugs. Table 2 lists dry torque limits. Dry torque limits are used on screws that do not have lubricants applied to the threads.

This is how to determine breakaway torque: Thread nut onto screw or bolt until at least two threads stick out. Nut shall not make contact with a mating part. Stop the nut. Torque necessary to begin turning nut again is the breakaway torque. Table 3 shows these limits for breakaway nut torque limits.

Table 1. (DISE only) Torque Limits for Circuit Breaker Lugs.

NOTE

On the M200 feeder center only, torque the main circuit breaker (200 Amp) input lugs to 180 lb-in (20.3 N.m). Torque all other circuit breaker lugs according to wire size connected as follows:

Wire Size AWG	Torque in.-lb +5 in.-lb	N.m ±0.6 N.m
18-20	25	2.8
10-14	30	3.4
8	30	3.4
6	35	4
4	35	4
3	35	4
2	40	4.5
1	45	5.1
1/0	50	5.7
2/0	50	5.7
4/0	50	5.7

NOTE

If you have PDISE equipment, torque all circuit breaker lugs according to wire size as follows:

Table 2. (PDISE) Torque Limits for Circuit Breaker Lugs.

Wire Size AWG	Torque in.-lb	N.m.
18	20-23	2.3-2.6
14-10	33-35	3.7-4
8	38-40	4.3-4.5
6-4	42-45	4.7-5
3-1/0	45-50	5-5.7
4/0	275	31

NOTE

Do not reuse self-locking nuts that do not meet minimum breakaway torque.

Table 3. Torque Limits for Self-Locking Nuts.

Minimum Breakaway Thread Size	Torque in.-lb (N.m)	Thread Size	Minimum Breakaway Torque in.-lb (N.m)
10-32	2.0 (0.23)	5/8-18	32.0 (3.62)
1/4-28	3.5 (0.40)	3/4-16	50.0 (5.65)
5/16-24	6.5 (0.73)	7/8-14	70.0 (7.91)
3/8-24	9.5 (1.07)	1-12	90.0 (10.17)
7/16-20	14.0 (1.58)	1-1/8-12	117.0 (13.22)
1/2-20	18.0 (2.03)	1-1/4-12	143.0 (16.16)
9/16-18	24.0 (2.71)		

END OF WORK PACKAGE

Chapter 8

REAR MATTER

RECOMMENDED CHANGES TO PUBLICATIONS AND BLANK FORMS For use of this form, see AR 25-30; the proponent agency is OAASA				Use Part II (reverse) for Repair Parts and Special Tool Lists (RPSTL) and Supply Catalogs/Supply Manuals (SC/SM).		DATE 30 August 2002
TO: (Forward to proponent of publication or form) (Include ZIP Code) Commander, US Army CECOM LCMC ATTN: AMSEL-LC-LEO-E-ED Fort Monmouth, NJ 07703-5006				FROM: (Activity and location) (Include ZIP Code) Jane Q. Doe, SFC 1234 Any Street Anytown, AL 34565		
PART I - ALL PUBLICATIONS (EXCEPT RPSTL AND SC/SM) AND BLANK FORMS						
PUBLICATION/FORM NUMBER TM 11-1234-567-14				DATE 16 Sep 2001		TITLE Operator, Field and Sustainment Support Maintenance Manual for Radio, AN/ABC-123
ITEM	PAGE	PARA-GRAPH	LINE	FIGURE NO.	TABLE	RECOMMENDED CHANGES AND REASON
1	WP0005 PG 3		2			Test or Corrective Action column should identify a different WP number.
TYPED NAME, GRADE OR TITLE Jane Q. Doe, SFC				TELEPHONE EXCHANGE/AUTOVON, PLUS EXTENSION 123-4567		SIGNATURE

EXAMPLE

TO: (Forward to proponent of publication or form) (Include ZIP Code)				FROM: (Activity and location) (Include ZIP Code)			DATE	
PART II- REPAIR PARTS AND SPECIAL TOOL LISTS AND SUPPLY CATALOGS/SUPPLY MANUALS								
PUBLICATION/FORM NUMBER				DATE		TITLE		
PAGE NO.	COLM NO.	LINE NO.	NATIONAL STOCK NUMBER	REFERENCE NO.	FIGURE NO.	ITEM NO.	TOTAL NO. OF MAJOR ITEMS SUPPORTED	RECOMMENDED ACTION
EXAMPLE								
PART III - REMARKS (Any general remarks, recommendations, or suggestions for improvement of publications and blank forms. Additional sheets may be used if more space is needed.)								
EXAMPLE								
TYPED NAME, GRADE OR TITLE			TELEPHONE EXCHANGE/AUTOVON, PLUS EXTENSION			SIGNATURE		

RECOMMENDED CHANGES TO PUBLICATIONS AND BLANK FORMS For use of this form, see AR 25-30; the proponent agency is OAASA					Use Part II (reverse) for Repair Parts and Special Tool Lists (RPSTL) and Supply Catalogs/Supply Manuals (SC/SM).		DATE
TO: (Forward to proponent of publication or form) (Include ZIP Code)					FROM: (Activity and location) (Include ZIP Code)		
PART I - ALL PUBLICATIONS (EXCEPT RPSTL AND SC/SM) AND BLANK FORMS							
PUBLICATION/FORM NUMBER					DATE		TITLE
ITEM	PAGE	PARA-GRAPH	LINE	FIGURE NO.	TABLE	RECOMMENDED CHANGES AND REASON	
TYPED NAME, GRADE OR TITLE				TELEPHONE EXCHANGE/AUTOVON, PLUS EXTENSION		SIGNATURE	

TO: <i>(Forward to proponent of publication or form) (Include ZIP Code)</i>	FROM: <i>(Activity and location) (Include ZIP Code)</i>	DATE
--	--	-------------

PART II- REPAIR PARTS AND SPECIAL TOOL LISTS AND SUPPLY CATALOGS/SUPPLY MANUALS

PUBLICATION/FORM NUMBER			DATE		TITLE			
PAGE NO.	COLM NO.	LINE NO.	NATIONAL STOCK NUMBER	REFERENCE NO.	FIGURE NO.	ITEM NO.	TOTAL NO. OF MAJOR ITEMS SUPPORTED	RECOMMENDED ACTION

PART III - REMARKS *(Any general remarks or recommendations, or suggestions for improvement of publications and blank forms. Additional blank sheets may be used if more space is needed.)*

TYPED NAME, GRADE OR TITLE	TELEPHONE EXCHANGE/AUTOVON, PLUS EXTENSION	SIGNATURE
----------------------------	--	-----------

RECOMMENDED CHANGES TO PUBLICATIONS AND BLANK FORMS					Use Part II (<i>reverse</i>) for Repair Parts and Special Tool Lists (RPSTL) and Supply Catalogs/Supply Manuals (SC/SM).		DATE
For use of this form, see AR 25-30; the proponent agency is OAASA							
TO: (<i>Forward to proponent of publication or form</i>) (<i>Include ZIP Code</i>)					FROM: (<i>Activity and location</i>) (<i>Include ZIP Code</i>)		
PART I - ALL PUBLICATIONS (EXCEPT RPSTL AND SC/SM) AND BLANK FORMS							
PUBLICATION/FORM NUMBER					DATE		TITLE
ITEM	PAGE	PARA- GRAPH	LINE	FIGURE NO.	TABLE	RECOMMENDED CHANGES AND REASON	
TYPED NAME, GRADE OR TITLE				TELEPHONE EXCHANGE/AUTOVON, PLUS EXTENSION		SIGNATURE	

TO: (Forward to proponent of publication or form) (Include ZIP Code)	FROM: (Activity and location) (Include ZIP Code)	DATE
---	---	-------------

PART II- REPAIR PARTS AND SPECIAL TOOL LISTS AND SUPPLY CATALOGS/SUPPLY MANUALS

PUBLICATION/FORM NUMBER			DATE	TITLE				
PAGE NO.	COLM NO.	LINE NO.	NATIONAL STOCK NUMBER	REFERENCE NO.	FIGURE NO.	ITEM NO.	TOTAL NO. OF MAJOR ITEMS SUPPORTED	RECOMMENDED ACTION

PART III - REMARKS (Any general remarks or recommendations, or suggestions for improvement of publications and blank forms. Additional blank sheets may be used if more space is needed.)

TYPED NAME, GRADE OR TITLE	TELEPHONE EXCHANGE/AUTOVON, PLUS EXTENSION	SIGNATURE
----------------------------	--	-----------

RECOMMENDED CHANGES TO PUBLICATIONS AND BLANK FORMS For use of this form, see AR 25-30; the proponent agency is OAASA					Use Part II (reverse) for Repair Parts and Special Tool Lists (RPSTL) and Supply Catalogs/Supply Manuals (SC/SM).		DATE
TO: (Forward to proponent of publication or form) (Include ZIP Code)					FROM: (Activity and location) (Include ZIP Code)		
PART I - ALL PUBLICATIONS (EXCEPT RPSTL AND SC/SM) AND BLANK FORMS							
PUBLICATION/FORM NUMBER					DATE		TITLE
ITEM	PAGE	PARA-GRAPH	LINE	FIGURE NO.	TABLE	RECOMMENDED CHANGES AND REASON	
TYPED NAME, GRADE OR TITLE				TELEPHONE EXCHANGE/AUTOVON, PLUS EXTENSION		SIGNATURE	

TO: <i>(Forward to proponent of publication or form) (Include ZIP Code)</i>	FROM: <i>(Activity and location) (Include ZIP Code)</i>	DATE
--	--	-------------

PART II- REPAIR PARTS AND SPECIAL TOOL LISTS AND SUPPLY CATALOGS/SUPPLY MANUALS

PUBLICATION/FORM NUMBER			DATE		TITLE			
PAGE NO.	COLM NO.	LINE NO.	NATIONAL STOCK NUMBER	REFERENCE NO.	FIGURE NO.	ITEM NO.	TOTAL NO. OF MAJOR ITEMS SUPPORTED	RECOMMENDED ACTION

PART III - REMARKS *(Any general remarks or recommendations, or suggestions for improvement of publications and blank forms. Additional blank sheets may be used if more space is needed.)*

TYPED NAME, GRADE OR TITLE	TELEPHONE EXCHANGE/AUTOVON, PLUS EXTENSION	SIGNATURE
----------------------------	--	-----------

By Order of the Secretary of the Army:

Official:

JOYCE E. MORROW
*Administrative Assistant to the
Secretary of the Army*
0829412

GEORGE W. CASEY, JR
*General, United States Army
Chief of Staff*

By Order of the Secretary of the Air Force:

Official:

BRUCE CARLSON
General, USAF
Command, AFMC

T. MICHAEL MOSELEY
General, USAF
Chief of Staff

Army Distribution:

To be distributed in accordance with the initial distribution number (IDN) 0255782 requirements for TM 9-6150-226-13.

